

Installation, Operation, Maintenance Manual



NBS[®]90 PolySort Narrow Belt Sorter (NBS)

IOM Part Number: 1193974

Revision Date: October 31, 2024

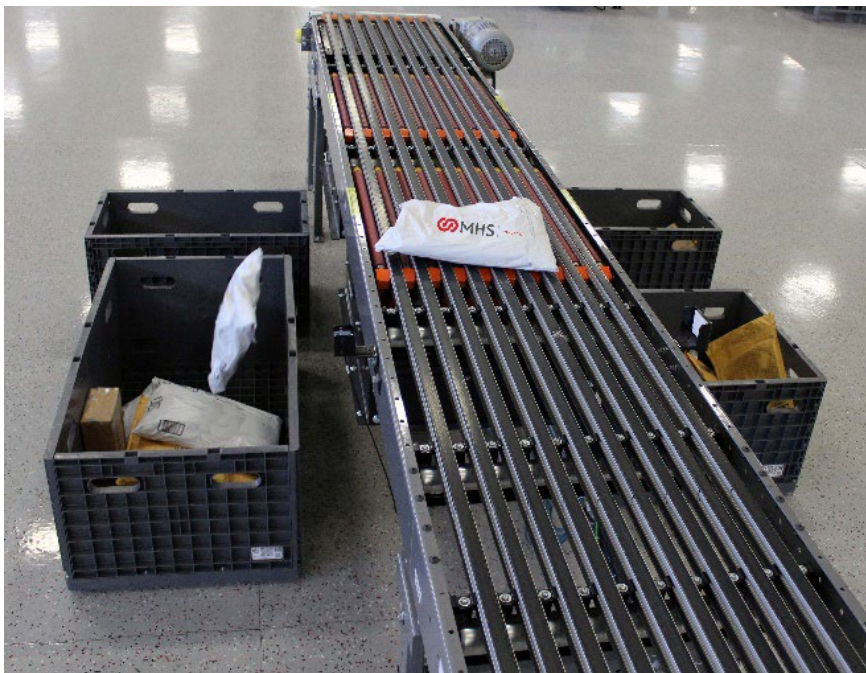



TABLE OF CONTENTS

TABLE OF CONTENTS	2
1 IOM INTRODUCTION	4
2 MHS CONVEYOR POLICIES	5
2.1 MHS RECOMMENDS PROPER LABELS FOR CONVEYOR TYPES.....	7
3 WARNINGS AND SAFETY INSTRUCTIONS	8
3.1 SYMBOLS USED THROUGHOUT THE MANUAL.....	8
3.2 MHS CONVEYOR CONTROLS SAFETY GUIDELINES	13
4 NBS®90 POLYSORT INTRODUCTION	15
4.1 NBS90 POLYSORT APPLICATION OPTIONS.....	15
4.2 NBS90 POLYSORT TRANSFER ROLLER ADJUSTMENT GUIDE.....	19
4.3 DEFINITION OF TERMS.....	20
5 NBS RECEIVING & SITE PREPARATION	23
5.1 NBS PARTS INVENTORY & IDENTIFICATION	24
6 NBS INSTALLATION DETAILS	26
6.1 NBS GENERAL ELECTRICAL REQUIREMENTS	27
6.2 NBS90 POLYSORT MHS CONVEYOR CONTROLS GUIDELINES.....	29
6.3 NBS GEAR MOTOR ACTIVATION	37
6.4 DIMENSIONAL REFERENCE POINTS.....	39
6.5 NBS ELEVATIONS.....	40
6.6 NBS SUPPORTING ARRANGEMENT	41
6.7 NBS SUPPORTS & CONNECTIONS	42
6.8 NBS90 POLYSORT BED CONNECTION KIT	43
6.9 NBS90 POLYSORT COMPONENT ORIENTATION	44
6.10 NBS90 POLYSORT TRANSFER GENERAL LAYOUT	45
6.11 NBS90 POLYSORT PHOTOEYE.....	46
6.12 NBS90 POLYSORT CEILING SUPPORTED.....	48
6.13 NBS ALUMINUM EXTRUSION T-NUT CONNECTORS.....	50
6.14 NBS BELT INSTALLATION	51
6.15 NBS BELT SPECIFICATIONS AND LACING.....	53
6.16 NBS PNEUMATIC GENERAL GUIDELINES.....	54



6.17 NBS90 POLYSORT PNEUMATIC..... 55

6.18 NBS90 POLYSORT AIR TAKE-UP DIAGRAM..... 56

6.19 NBS90 POLYSORT AIR TRANSFER DIAGRAM..... 57

6.20 NBS90 POLYSORT AIR SUPPLY REQUIREMENTS..... 58

6.21 NBS90 POLYSORT AIR LINE CONNECTIONS 59

6.22 NBS AIR REGULATOR LOCK OUT VALVE ON AND OFF POSITION 60

6.23 NBS COMMISSIONING OF EQUIPMENT 61

6.24 NBS MAINTENANCE & TROUBLESHOOTING 63

6.25 GEARMOTOR 63

6.26 ROLLERS 64

6.27 AIR SYSTEM 64

6.28 MOTOR CONTROLS 65

6.29 NBS MAINTENANCE CHECKLIST 66

6.30 MAINTENANCE SCHEDULE..... 67

6.31 NBS TROUBLESHOOTING GUIDE 69

7 NBS REPAIR OR REPLACE PROCEDURES..... 70

7.1 GEARMOTORS 70

7.2 SOLENOID VALVES 70

7.3 NBS 90 POLYSORT TRANSFER REPLACE THE HABASIT BELT..... 71

8 PARTS IDENTIFICATION 73

8.1 REPLACEMENT PARTS IDENTIFICATION..... 73

8.2 SPARE PARTS PRIORITY LEVEL EXPLANATIONS 73

8.3 NBS90 POLYSORT INTERMEDIATE BED AR W/AIR TAKE-UP 4’0” 74

8.4 NBS90 POLYSORT STANDARD END DRIVE AR..... 76

8.5 NBS90 POLYSORT BELT TAKE-UP 78

8.6 NBS90 POLYSORT TRANSFER ASSEMBLY 79

8.7 NBS90 POLYSORT END PULLEY AR 1’6” 80

8.8 NBS90 POLYSORT 4’ END PULLEY BED WITH AIR TAKE-UP..... 81

8.9 NBS90 POLYSORT ENCODER ASSEMBLY 82

9 NBS90 POLYSORT REVISION HISTORY 83

MHS GENERAL INFORMATION 83

ABOUT MHS CONVEYOR..... 84

1 IOM INTRODUCTION

IOM Purpose

It is the intent of MHS Conveyor, through this manual, to provide information that acts as a guide in the installation, operation, and maintenance of MHS Conveyor conveyors.

This manual describes basic installation practices, assembly arrangements, preventive maintenance, and assists in replacement parts identification.

This service manual is intended for use by personnel who are knowledgeable of installation and safe working practices on conveyor systems.

Not all applications and conditions can be covered; therefore, this manual is to be used ONLY as a guide.

If additional copies of this manual are needed or if you have any question concerning the conveyor, please contact your MHS Conveyor Distributor or MHS Conveyor Lifetime Services at 231-798-4547 or visit MHS at www.mhs-conveyor.com for maintenance videos and other application information.

Manual Structure

You should receive separate documentation for each product line of MHS Conveyor implemented in your installation. You can identify the respective product line on the back of the folder or on the cover sheet of the IOM (Installation Operation Maintenance Manual)

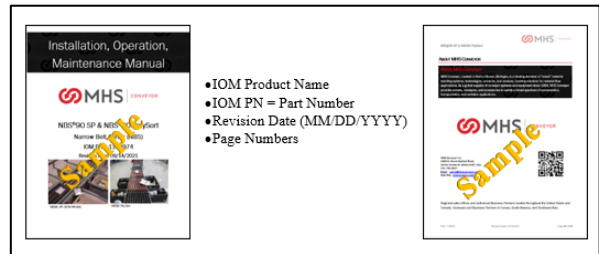

WARNING



- Pay attention to the safety instructions!
- Prior to working at or in the immediate vicinity of the system it is recommended that you make yourself familiar with the safety instructions included in the present document!



2 MHS CONVEYOR POLICIES

MHS Conveyor Equipment Warranty

MHS Conveyor warrants that the material and workmanship entering into its equipment is merchantable and will be furnished in accordance with the specifications stated.

MHS Conveyor agrees to furnish the purchaser without charge any part proved defective within 2 years from date of shipment provided the purchaser gives MHS Conveyor immediate notice in writing and examination proves the claim that such materials or parts were defective when furnished. For drive components specific to XenoROL® (i.e., Xeno belts, slave Xeno belts, drive spools, standard and speed-up, and spacers), this warranty shall be extended to five years of running use, provided the conveyors are applied, installed, and maintained in accordance with MHS Conveyor published standards. Other than the above, there are no warranties which extend beyond the description on the face hereof. Consequential damages of any sort are wholly excluded.

The liability of MHS Conveyor will be limited to the replacement cost of any defective part. All freight and installation costs relative to any warranted part will be at the expense of the purchaser. Any liability of MHS Conveyor under the warranties specified above is conditioned upon the equipment being installed, handled, operated, and maintained in accordance with the written instructions provided or approved in writing by MHS Conveyor.

The warranties specified above do not cover, and MHS Conveyor makes no warranties which extend to, damage to the equipment due to deterioration or wear occasioned by chemicals, abrasion, corrosion, or erosion; Purchaser's misapplication, abuse, alteration, operation, or maintenance; abnormal conditions of temperature or dirt; or operation of the equipment above rated capacities or in an otherwise improper manner.

THERE ARE NO WARRANTIES, EXPRESSED OR IMPLIED, INCLUDING, BUT NOT LIMITED TO, WARRANTIES OF MERCHANTABILITY OR FITNESS FOR A PARTICULAR PURPOSE, EXTENDING BEYOND THOSE SET FORTH IN THIS STATEMENT OF WARRANTY.

Rev 08/12/2021



MHS Environment Standards

MHS Conveyor equipment is designed to be installed in a clean, dry warehouse environment. Exposure to extreme humidity, direct sunlight, blowing dirt or rain can permanently damage some components of MHS Conveyor. In particular, the curing agents in concrete are known to attack and degrade the urethane conveyor components.

When installing conveyor on a new construction site, be sure that the concrete is properly cured before setting conveyor on it. In addition, if conveyors are stored in the proximity of curing concrete, proper ventilation must be used to direct the curing agent fumes away from the conveyor.

Failure to comply with these guidelines will void the MHS warranty on any failed components that result from these environment issues.

08/12/2021

 WARNING	
	<p>Hazard to Equipment or Personnel</p> <ul style="list-style-type: none">• Safety: Always lock out power source and follow recommended safety procedures. https://www.osha.gov/
<p>Indicates a medium level potentially hazardous situation that, if not avoided, could result in death or serious injury.</p>	

2.1 MHS RECOMMENDS PROPER LABELS FOR CONVEYOR TYPES

Shown below are samples of labels applicable to conveyor standards.

CEMA Package Conveyors SAFETY IN YOUR HANDS

- Do Not Climb, Sit, Stand, Walk, Ride, or Touch the Conveyors at Any Time.
- Do Not Perform Maintenance on Conveyors until Electrical, Air, Hydraulic and Gravity Energy Sources Have Been Locked Out and Blocked.
- Operate Equipment Only with All Appropriate Guards and Shields in Place.
- Do Not Load a Stopped Conveyor or Overload a Running Conveyor.
- Ensure That All Personnel are Clear of Equipment Before Starting.
- Allow Only Authorized Personnel to Operate or Maintain Material Handling Equipment.
- Do Not Modify or Misuse Conveyor Controls.
- Keep Clothing, Body Parts and Hair Away from Conveyors.
- Remove Trash, Paperwork and Other Debris Only When Power is Locked Out.
- Ensure That All Controls and Pull Cords are Visible and Accessible.
- Know the Location and Function of All Stop and Start Controls.
- Report All Unsafe Conditions.

POST IN PROMINENT AREA

Product: Unit Handling
Equipment: Motor Driven Live Roller Conveyors

To be placed along both sides of these conveyors since these conveyors provide surfaces and profiles attractive, but hazardous, for climbing, sitting, walking, or riding.

To be placed along the sides of these conveyors to warn personnel that the conveyor can start automatically.

"A"
SPRICE UP TO A MAXIMUM OF 20 FT. CENTERS (BOTH SIDES)

"C"
SPRICE UP TO A MAXIMUM OF 20 FT. CENTERS (BOTH SIDES)

"B"
SPRICE UP TO A MAXIMUM OF 20 FT. CENTERS (Sides or top surface of both rails)

"D"
SPRICE UP TO A MAXIMUM OF 20 FT. CENTERS (Sides or top surface of both rails)

"B"/"D" OPTIONAL

20' FT. MAXIMUM

"A"/"B"
"C"/"D"

NOTE: Due to the design of these conveyors, there may not be room on the side rails to place the larger labels. In that case, the smaller labels may be used. Optionally, they may also be placed on the top surface of both rails. The key is the space available and visibility by operators and maintainers.

CEMA - August, 2010 UH - 8

CEMA Safety Labels Placement Guidelines

Product: Unit Handling Equipment
Equipment: Live Roller Conveyors - Belt Driven

To be located on conveyors where there are exposed moving parts which must be exposed to facilitate function, i.e. rollers, pulleys, shafts, chains, etc.

To be placed along both sides of these conveyors since these conveyors provide surfaces and profiles attractive, but hazardous, for climbing, sitting, walking, or riding.

To be placed on removable guards to warn that operation of the machinery with guards removed will expose chains, belts, gears, shafts, pulleys, couplings, etc. which create hazards.

"A"
LOCATE AT TERMINAL ENDS (BOTH SIDES)

"B"
SPACE UP TO A MAXIMUM OF 20 FT. CENTERS (BOTH SIDES)

"C"
LOCATE ON DRIVE GUARDS AND DAMN BELT GUARDS

"D"
LOCATE ON DRIVE SECTION (BOTH SIDES)

END DRIVE

General purpose label to warn maintenance personnel that conveyors should be shut off and locked out prior to servicing. Examples: drives, take-up, calibration points which require guard removal.

CEMA UH-4

CEMA Safety Labels Placement Guidelines

Product: Unit Handling Equipment
Equipment: Belt Conveyors - End Driven

To be located on conveyors where there are exposed moving parts which must be exposed to facilitate function, i.e. rollers, pulleys, shafts, chains, etc. which create hazards.

To be placed along both sides of these conveyors since these conveyors provide surfaces and profiles attractive, but hazardous, for climbing, sitting, walking, or riding.

To be placed on removable guards to warn that operation of the machinery with guards removed will expose chains, belts, gears, shafts, pulleys, couplings, etc. which create hazards.

"A"
LOCATE AT TERMINAL ENDS (BOTH SIDES)

"B"
SPACE UP TO A MAXIMUM OF 20 FT. CENTERS (BOTH SIDES)

"C"
LOCATE ON CHAIN GUARDS

"D"
LOCATE ON DRIVE SECTION (BOTH SIDES)

END DRIVE

General purpose label to warn maintenance personnel that conveyors should be shut off and locked out prior to servicing. Examples: drives, take-up, calibration points which require guard removal.

CEMA UH-5



3 WARNINGS AND SAFETY INSTRUCTIONS



3.1 SYMBOLS USED THROUGHOUT THE MANUAL



Failure to follow the instructions and cautions throughout this manual and warning label on the conveyor may result in injury to personnel or damage to the equipment.

Your MHS Conveyor is powered by a motor and can be stopped only by turning off electrical power to the motor. As with all powered machinery, the drive-related components – including sprockets, chains, shafts, universal joints, and pneumatic devices – can be dangerous. We have installed or provided guards to prevent accidental contact with these parts, along with warning labels to identify the hazards.

Special attention must be made to the following areas of this manual. Listed below are some symbols used throughout the manual to emphasize information of significant importance.





 DANGER	
	Indicates a high level potentially hazardous situation which, if not avoided, will result in death or serious injury.











 WARNING	
	Indicates a medium level potentially hazardous situation that, if not avoided, could result in death or serious injury.

 CAUTION	
	Indicates a low level potentially hazardous situation which, if not avoided, could result in minor or moderate injury. It may also be used to alert against unsafe practices or for the protection of the equipment.

NOTICE	
	Failure to follow these instructions can result in property damage or equipment damage.

3.1.1 Obligations





	<h2>The Workers MUST DO!</h2>
   	<ul style="list-style-type: none"> • Must Do, carry out maintenance operations with the conveyor equipment switched off. Do not lubricate moving parts. • Must Do, parts over 18kg should be lifted by two people. • Must Do, step ladder must be used when performing maintenance or cleaning on items that cannot be reached from floor level. • Must Do, tie up long hair or long beards, avoid wearing scarves or other clothes that may get trapped in the moving parts of the partly completed machine. All loose clothing, long hair, long beards, and jewelry must be kept away from moving equipment. • Must Do, remove jewelry such as bracelets, rings or necklaces that may get trapped in moving parts, thus creating a risk for the operator. • Must Do, always perform interventions on the electrical system components in the absence of voltage (main switch off). • Must Do, make sure that no-one is standing in the danger zones during the start-up and operation of the conveyor machine. • Must Do, use extreme caution to avoid injury or property damage during use of the partly completed machine. • Must Do, know the location and operation of the stopping device. • Must Do, comply with instructions and provisions given by the employer, managers, or supervisors, to ensure personal and collective safety. • Must Do, make proper use of equipment, tools, substances, and dangerous products, means of transport and other working machinery, as well as safety devices. • Must Do, make correct use of all personal protective equipment they have been provided with • Must Do, after maintenance, must REPLACE guards immediately. • Must Do, keep ALL warning labels clean and clear of any obstructions. • Must Do, must be trained to never remove, deface, or paint over symbols or labels of any kind. Any damaged label can be replaced by MHS CONVEYOR by contacting Lifetime Services. • Must Do, it is very important to instruct personnel in proper conveyor use, including the location and function of all controls. • Must Do, special emphasis must be given to emergency stop procedures. • Must Do, it is important to establish work procedures and access areas, which do not require any part of a person to be under the conveyor. • Must Do, after the power source is turned off and locked out trained maintenance technician are to remove blockage or jams from the conveyor equipment. • Must Do, maintain enough clearance on each side of all conveyor units for safe adjustment and maintenance of all components • Must Do, provide crossovers or gates at sufficient intervals where needed to eliminate the temptation for personnel to climb over or under any conveyor.

	<h2>The Workers MUST DO!</h2>
<div style="display: flex; flex-direction: column; align-items: center; gap: 10px;">      <div style="display: flex; gap: 10px;">   </div> <div style="display: flex; gap: 10px;">   </div> </div>	<ul style="list-style-type: none"> Must Do, use the conveyor equipment within the approved environmental conditions. Must Do, BEFORE performing maintenance on the conveyor, make sure the start-up controls are locked out and cannot be turned on by any person other than the one performing the maintenance. Must Do, if more than one crew member is working on the conveyor, EACH CREW MEMBER MUST HAVE A LOCK ON THE POWER LOCKOUT. Must Do, maintain enough clearance on each side of all conveyor units for safe adjustment and maintenance of all components. Must Do, all pneumatic devices must be de-energized, and air removed to prevent accidental cycling of the device while performing general maintenance. Must Do, make sure all personnel are clear of all conveyor equipment before restarting the system. Must Do, watch for nip points or pinch points. A pinch point hazard is a common class of mechanical hazard where injury or damage may be done by one or more objects moving towards each other, crushing, or shearing whatever comes between them. A nip point is a type of pinch point involving rotating objects, such as gears and pulleys. Must Do, BEFORE restarting a conveyor, which has been stopped because of an emergency, an inspection of the conveyor must be made, and the cause of the stoppage determined. The starting device must be locked out before any attempt is made to correct the cause of stoppage. Must Do, make correct use of all personal protective equipment that they have been provided with. Must Do, know the workplace and traffic routes, and all required protections/guarding of nearby hazardous equipment. Must Do, employees that come in contact with the equipment must be warned of the dangers of an unexpected start. Must Do, hands can be crushed between products or products and channels. Must Do, the user shall be careful to ensure a regular feed, avoiding overloading. Must Do, all loading and working places, passageways, shall be kept clear. Must Do, BEFORE servicing or performing any work in the motor control panel, disconnect and padlock out air and the main incoming service. If ONLY the panel disconnect is off, the incoming side will still be hot. Must Do, all safety rules must be observed when working with, on or at the conveyor system in whatever way. This includes reading all installation, operation, maintenance, or technical manuals. Must Do, know that motor rollers can become hot! Must Do, know workplace and traffic routes may require additional protections/guarding if nearby hazardous equipment.

	<h2 style="margin: 0;">The Workers MUST DO!</h2>
<div style="display: flex; flex-direction: column; align-items: center; justify-content: center; gap: 20px;"> </div>	<ul style="list-style-type: none"> Employees that come in contact with the equipment must be warned of the dangers of unexpected start. Hands can be crushed between products or products and channels. <div style="text-align: center; margin: 10px 0;"> </div> <ul style="list-style-type: none"> Before servicing or performing any work in the motor control panel, disconnect and lock out air and the main incoming service. If only the panel disconnect is off, the incoming side will still be hot. <div style="text-align: center; margin: 10px 0;"> </div> <ul style="list-style-type: none"> Safety WARNING Label Lock Out Power
<p>Indicates a medium level potentially hazardous situation that, if not avoided, could result in death or serious injury.</p> <p>Mandatory action symbols are used to draw attention to a supplementary sign for a specified mandatory action.</p> <p>The mandatory action symbol is used to identify particularly important information inside the manual. The information also regards the safety of personnel involved use of the partly completed machine.</p>	

3.1.2 Prohibitions

Listed are prohibitions and are mandatory **Must Not Do** to avoid the hazard!

	<p>THE WORKER MUST NOT!</p>
   	<ul style="list-style-type: none"> • Must Not, use the conveyor equipment improperly, i.e., for uses other than those indicated in the “Intended use” paragraph. • Must Not, remove or modify the safety or signaling devices without authorization. • Must Not, remove, deface, or paint over symbols or labels of any kind. Any damaged label can be replaced by MHS CONVEYOR by contacting Lifetime Services. • Must Not, convey hazardous materials. • Must Not, Walking or riding on a conveyor equipment /moving conveyor must be prohibited. No person shall ride, sit, or stand on a conveyor under any circumstances. • Must Not, remove or install heavy parts whilst anyone is working on the floor level below the parts to be moved. This will help stop accidental falling of heavy parts onto people. • Must Not, carry out, upon their own initiative, operations or maneuvers they are not in charge of and that can jeopardize their own safety and that of other workers. • Must Not, wear bracelets, rings or necklaces that may get trapped in moving parts, thus creating a risk for the operator. • Must Not, modification of the design or configuration of the equipment may lead to new hazards or higher risk that are not reduced adequately by the risk reduction measures of the manufacturer. • Must Not, replace or modify the speed of the conveyor equipment components without being authorized by a manager. • Must Not, modify the conveyor equipment operating cycle. • Must Not, modify the connections to exclude the internal safety devices. • Must Not, use the conveyor equipment if not properly incorporated within the final line, according to current regulations. • Must Not, use the conveyor equipment or its components as point of support even if not operational (risk of falls and/or risk of damaging the components themselves). • Must Not, use the conveyor equipment outside of the admitted environmental conditions. • Must Not, touch Motor rollers as they can become hot! • Must Not, touch any type of Motor as the motor may be hot! • Must Not, clear jams while the equipment is running. • Must Not, do not pull-on equipment parts, such as belts, pulleys, or shafts, to assist slow starting equipment.
<p>Indicates a high level potentially hazardous situation which, if not avoided, will result in death or serious injury.</p> <p>Symbol used to identify operations that must not be performed or behaviors that must not be adopted as they could cause injury to personnel or damage to the partly completed machine.</p>	

3.2 MHS CONVEYOR CONTROLS SAFETY GUIDELINES

The following basic conveyor control safety guidelines are recommended by MHS Conveyor even though Business Partner may or may not purchase conveyor controls from MHS Conveyor. The items listed deal with applications of controls equipment. **The actual installation of the equipment must always follow the National Electric Code and all other local codes.**

Start-up Warning Horn

Ideally, all conveyors should be within sight of the conveyor start pushbutton. This allows the operator to verify that no one is touching the conveyor or would be in danger if the conveyor were to start up.

If it is not possible to see the entire conveyor being started from the start pushbutton location, then some form of audible warning device is required. It could be a horn, buzzer, bell, or anything unique to that conveyor for that location. It should be loud enough to be heard at any point on the conveyor system. It should sound for approximately five seconds after the start pushbutton is pushed, prior to the actual running of conveyor. Any auxiliary equipment such as vertical lifts, turntables, etc., should also be included in the warning circuitry.

Conveyors that stop and restart under automatic control could also require a horn warning prior to restarting. If it is not easy to distinguish the difference between a fully stopped conveyor system and a momentarily stopped conveyor section, then it is advisable to add a warning horn. All conveyor sections that stop and restart automatically should be marked with appropriate signs or labels.

Start Pushbuttons

Start pushbuttons should be the flush type or guarded such that inadvertently leaning against them will not actuate the conveyor. They should be provided with a legend plate clearly defining which conveyors will be started.

Stop Pushbuttons

Stop pushbuttons should be the extended type such that any contact with it is sufficient to stop the conveyor. They would also be provided with a legend plate clearly defining which conveyors will be stopped.

Operator Controls

Additional operator controls should be designed into the system with the same guidelines that go into start and stop pushbuttons, depending upon their function. Devices which are repeated on multiple control stations, such as emergency stops, should be located at the same relative location on each station (such as lower right corner).

Emergency Stops

All locations where an operator must work directly at the conveyor may be subject to local safety codes requiring e-stops. It is the responsibility of the integrator to check with state and local authorities on the need and application of e-stops.

Emergency stops can be of the pushbutton or cable operated switch type. The pushbutton type should be a red, mushroom head maintained pushbutton which requires resetting after it is actuated. Cable operated switches should trip by pulling the cable and require resetting at the switch.

Actuating an emergency stop must drop-out the start circuit, requiring restarting the system using the start pushbuttons provided.

An emergency stop should normally stop all conveyors in the system. Very large systems may involve dividing a system into zones of control based on proximity of personnel, safety hazards, walls obstacles, etc.

Controls Logic

Solid state controls logic devices, such as programmable controllers are used extensively for conveyor control. They are very reliable, but a hardware failure or software bug would cause an output to function erratically. For this reason, start circuits, warning horn circuits, and emergency stops should usually be configured using conventional relay logic.

Safety Switches

All conveyor control cabinets and motors should be provided with safety (or disconnect) switches. These switches must have provisions for padlocking. As required for maintenance, equipment should be locked in the off position.

Special Devices

Special devices and equipment such as vertical lifts, turntables, high speed conveyors, etc., all have unique design and safety requirements. These should be looked at in each case to determine what the requirements might be.

04/06/2023

4 NBS[®]90 POLYSORT INTRODUCTION

NBS90 PolySort Selection

Due to the high degree of polybag variance and physical characteristics of typical contents (e.g., pliable, irregular, light, loose, etc.) it is vital for the Systems Integrator to fully understand the physical parameters of all conveying products and how well it should perform for the full product range expected to convey. It remains the responsibility of the Systems Integrator to ensure that the equipment proposed is capable of handling the products in the manner desired.



4.1 NBS90 POLYSORT APPLICATION OPTIONS

The PolySort unit is designed specifically with polybag handling in mind, as shown by the following features:

- Transfer Tubs have extra high lift and drop above/below the conveying surface by 1/2” to allow for loosely packed polybags.
- Belts and Divert Rollers are on tighter 2-1/2” centers to help support pliable or irregular products
- High friction Divert Rollers stop and convey polybags quickly “on the fly”
 - **Note for Carton Handling:**
 - The high friction surface can cause higher center of gravity products to tip at high speeds and rates. Generally, products convey well if the center of gravity is no more than 25% of product width or height. **Consult with Applications Engineering for your specific application.**
- Transfer Tubs use high performance SEW Movimot drive motors for quick response and high efficiency
- Bed Rail connections and infeed points are rounded and scalloped to reduce product snagging
- Divert Tubs are fitted with infeed ramps between each lane to minimize snagging and maximize rate
- Small Array Photo Eyes are used to sense products 5mm thick

Given the above design features, the nature of conveying products with irregular or loose conveying surfaces are not guaranteed. MHS has tested a wide range of products contained in polybags with successful convey with the vast majority of “normal” industry packaged polybags from companies in the Apparel, Postal/Parcel, and Distribution markets.

Consult with MHS Applications Engineering for your specific needs or to arrange product testing.

 WARNING	
	<ul style="list-style-type: none"> Post sort orientation may not be maintained. Typical divert is onto a chute, bin, tub or similar. Consult with MHS Applications Engineering for specific details or to arrange product testing.

Use NBS90 PolySort when:

- Tighter belt centers than our standard NBS is required
- Product may be same size and weight, or mixed
- Product weight: less than 2oz. – 40 lbs. Max, 1,000 lbs. total live load
- Products typically convey onto chute or dump into tote, Gaylord, or similar
- +50F to +120F. System requirements below +50F should be referred to the Applications Engineering department for analysis. Additional horsepower may be required.



NBS90 PolySort Application Notes:

- Matching conveyor rates before and after NBS sortation are vital to proper application decisions.
- If orientation integrity is required post transfer, products would need to be tested.
- The transfer exit lanes from NBS90 PolySort can be gravity roller (used as a deceleration area), chutes or powered conveyor run at a speed which allows the lane to receive products as fast as they are transferred.
- The maximum divert rate for a NBS90 PolySort single-direction is 50 CPM. The bidirectional rate is 50 CPM. (Contact the Customer Support group for application consideration above these rates)
- Induction to NBS90 PolySort sortation must be able to singulate individual products. Minimum induction gap varies with line speed and determine product pitch.
 - $Speed / Pitch = Rate$. Reference chart example below.

PolySort Rate w/Max Polybag				
Speed (FPM)	Min Gap (ins)	Max Prod Length	Pitch (ins)	Max Rate (CPM)
300	44	28	72	50

High rates are possible given ideal product size and type, edge aligned and induction control upstream of PolySort, and programming optimization. **Consult with MHS Applications Engineering for specific details or to arrange product testing.**

- To increase rate, justify all products along the exit lane side of the NBS90 PolySort sortation for single direction transfer.
- When NBS90 PolySort over-all-length is over 50' and up to 95' in length, an addition auxiliary air take-up is required.
- The maximum length of a NBS90 PolySort sortation conveyor, including two air take-up units, is 95'.

 CAUTION	
	<p>Hazard to Equipment</p> <ul style="list-style-type: none"> • The use of a VFD (Variable Frequency Drive) or at least a "soft start" motor drive is recommended for NBS90 PolySort drive motor control. Ignoring this point may void the motor warranty. • The use of a VFD (Variable Frequency Drive) is required for NBS drive motor control. Ignoring this point will void the belt motor manufacturer's warranty.
<p>Indicates a low level potentially hazardous situation which, if not avoided, could result in minor or moderate injury. It may also be used to alert against unsafe practices or for the protection of the equipment.</p>	

NBS90 PolySort Elevation Top of Belt

The minimum elevation at the discharge end of an NBS90 PolySort sortation line is 19". The end drive unit is located at the discharge end and requires a space of 60" or 33" long.

Extra room alongside the drive should be provided to allow maintenance personnel access to either side of the drive assembly. In order to remove air take-up from bottom side of conveyor, add 6" of clearance and 7" for transfers.

NBS90 PolySort Transfer Locations

- The leading edge of the first transfer module must be a minimum of 11 1/8" from the charge end of the sorter.
- The trailing edge of the last divert module must be at least 11 1/8" from the discharge end.
- The center line of a transfer exit lane is centered on the center line of the transfer rollers in an NBS90 PolySort.
- Standard available coated transfer rollers widths are: 25 1/2"
- One NBS90 PolySort transfer can transfer to up to four separate lanes of 1/2 the width of the roller length.
- Single direction transfer to two lanes is called a "Dual Transfer"
- Bi-directional transfer to two lanes each side is called a "Quad Transfer"

NBS90 PolySort Standard Available Selections

- Horsepower (HP)
 - 2HP, 3HP, 5HP
- Feet Per Minute (FPM)
 - 120, 210, 240, 270, 300

NBS90 PolySort Sorter Nominal Widths & Number of Belts

- 26.5 NBS90 PolySort with 9 Belts on 2-1/2" Centers

4.2 NBS90 POLYSORT TRANSFER ROLLER ADJUSTMENT GUIDE.

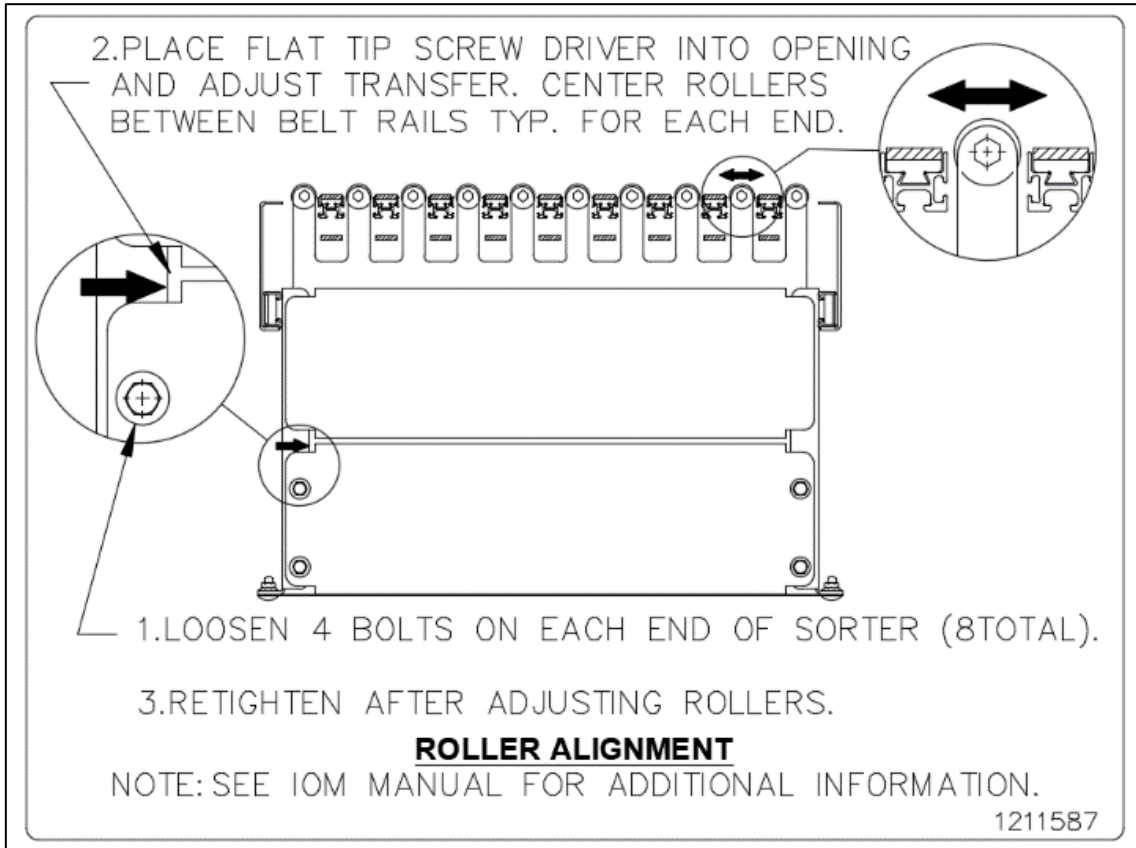

1. Loosen the 4 lower bolts on each end of transfer (8 total).
2. Place flat tip screwdriver into the opening and adjust transfer.
3. Center rollers between belt rails. For each end.
4. Adjust rollers until rollers no longer rub aluminum rails. Retighten bolts after adjusting.

Features and benefits

FEATURES:	BENEFITS:
Tighter belt centers vs standard NBS90	Prevents polybags from sagging between belts
Extra high/low transfer lift	Keeps polybags from dragging or snagging
High friction natural rubber transfer rollers	Maximum grab on a slippery polybag
High powered SEW transfer motor	Powerful acceleration for polybag transferring
Direct drive 97% efficient gearmotor on sorter drive	Eliminates all chain or drive belt maintenance
Individual belt take-ups	Even belt tension for unequal stretch or length
Use with extreme range of mixed product from 2oz. to 40lbs.	Adaptable to a wide range of customer needs

4.3 DEFINITION OF TERMS

Definition of Terms		
KEY WORD	ABBREVIATION	DESCRIPTION
ALUMINUM RAIL	AR	Original NBS UHMW belt guide holders
AIRBAG		Inflatable lifting device used in NBS30, NBS90, & NBS90 PolySort
BEARING	BRG	Low friction rotating or sliding device
BEAR RAIL	BR	NBS-BR belt guides composed of small ball bearings between steel side rails
BELT	BLT	Flexible load carrying surface or O-ring
BETWEEN-FRAME	BF	The distance between conveyor side frames
BRACKET	BRKT	Attachment between a main and another part
CHANNEL	CH	Structural side member of conveyor equipment
CONNECTOR	CONN	Holds two parts together (Mechanical or Electrical)
CROSSMEMBER	XM	Holds channels apart
DIVERTER		NBS30, NBS90, or NBS90 PolySort. Module
DRIVE	DR	Power unit at the discharge end of NBS sorter
ELEVATION	EL	Top-of belt height above base surface
ENCODER		Electrical distance counter used to track package location along the sorter length
END PULLEY	E-PULL	4" or 5" diameter roller at charge end of NBS sorter
EXTRUSION		Aluminum base that holds UHMW belt strips (See ALUMINUM RAIL)
FEET PER MINUTE	FPM	Speed sorter belts are traveling
FILTER / REGULATOR		Combination air pressure air filter / regulator
FLOOR STAND	FS	Name for conveyor bed support
FLOW CONTROL		Needle valve used to control airflow
GEARMOTOR	GEARMTR	One piece gear-reducer motor assembly
GUARD RAIL	GR	Angle or channel used to keep product on NBS
GUARD	GRD	Any part used to protect area for safety reasons
IDLER	IDL	Un-driven pulley used as a tensioning device
ITEM NUMBER	IT #	MHS Conveyor part identification number
KEY		Square locking device used on rotating shafts

Definition of Terms		
KEY WORD	ABBREVIATION	DESCRIPTION
KIT		Group of several parts with a single item number
LACED	LCD	The condition of a correctly installed lacing
LACING		Type or method of joining belts together (splice)
LIFT FRAME		The lifting structure of a NBS90 transfer
LIFT TABLE		Assembly that guides the NBS30 wheels upward
LOCKNUT		Self-locking fastener that resists vibration
LOCTITE		A thread-locking adhesive that resists vibration
LOOSE PARTS	LP	Individual parts that must be installed in the field
MODULE	MOD	A self-contained mechanical assembly
MOUNT	MNT	Part used to hold another, similar to a bracket
MOUNTING	MTG	Location and fasteners to attach a mount
MOTOR	MTR	Rotational power source usually using electricity
MUFFLER		Device used to reduce the noise of exhausted air
NATIONAL PIPE THREAD	NPT	Standard identifier for USA tapered pipe sizes
ORDER NUMBER	11 _ _ _ _ _ or 12 _ _ _ _ _	Original factory order / tracking number
O-RING		Polyurethane cord belts of differing lengths
PHOTOEYE	PE	Optical sensing device used for product control
PLATE	PL	Flat piece of metal usually bolted on for strength
PROGRAMMABLE LOGIC CONTROLLER	PLC	Self-contained programmable control unit that can control several input and output devices
PULLEY		Roller described by diameter and body length
REFLECTOR	RF	Target used to reflect a light back to a photo eye
REGULATOR	REG	Air device that reduces pressure to usable level
ROLLER		Described by axle size and BF dimension
SCANNER		A device that recognizes products by bar codes
SCHEMATIC		Line drawing of an electrical or pneumatic circuit
SEAL		Sealing device on a rotating shaft or cylinder rod
SHAFT		Round steel rod described by diameter and length
SHEAVE		A grooved disc that guides a V-belt or O-ring



Definition of Terms		
KEY WORD	ABBREVIATION	DESCRIPTION
SHIM		Thin piece of metal, used to fill up a space
SKATEWHEEL	SKW	2" diameter X 5/8" wide X 1/4" axle hole roller
SOCKET	SOC	Hex shaped hole in an Allen screw
SOLENOID	SOL	An electrically operated multi-position air valve
SPACER		Thick washer or tube that a fastener passes thru
SPLICE		Area where similar materials are joined together
SPRING	SPR	Coiled wire device used for un-powered return
SPROCKET	SPKT	Wheel with shaped teeth that engage roller chain
SPUR		Transition bed between a diverter and exit lane
STANDHEAD		Pivoting bracket that attaches support to the bed
STARTER		Electrical relay that energizes the drive motor
TAG		Number that identifies unit in system lay-out
TAKE-UP		Assembly used to remove slack from a belt / belt
TEE		A part with three connections locations
TENSIONER		A pneumatic, spring, or static take-up device
TRANSFER	TRNS	NBS90 module
ULTRA HIGH MOLECULAR WEIGHT	UHMW	Industry standard term for the hard milky white Polyethylene used in wearstrip applications
VALVE		An air shut-off or switching device
VENT		Small hole in gearbox to allow air expansion
WEARSTRIP		Low-friction material used to reduce rubbing wear
WELDMENT	WLDMT	Any part that requires welding in its manufacture
VFD	VFD	Variable Frequency Drive for motor speed control

5 NBS RECEIVING & SITE PREPARATION

General

MHS Conveyor NBS 90 PolySort are shipped in subassemblies. These subassemblies are packaged to guard against damage in shipment, when handled properly.

Examination immediately following unloading will show if any damage was caused during shipment. If damage is evident, claims for recovery of expenses to repair damage or replace components must be made against the carrier immediately. While unloading, a check must be made against the Bill of Lading, or other packing lists provided, to confirm full receipt of listed items.

 CAUTION	
	<p>Hazard of Equipment</p> <ul style="list-style-type: none">• TAKE CARE DURING THE REMOVAL OF EQUIPMENT FROM THE CARRIER. Remove small items and boxes first. Pull and lift only on the skid, not on the frame, cross member or any part of the equipment.• Do not remove finishing nails from rail ends. They keep the UHMW guides from sliding down to the discharge end.
<p>Indicates a low level potentially hazardous situation which, if not avoided, could result in minor or moderate injury. It may also be used to alert against unsafe practices or for the protection of the equipment.</p>	

Preparation of Site

After the conveyor is received, move it to the installation site or designated dry storage area as soon as possible. Clean up all packing material immediately before parts get lost in it. Loose parts should remain in the shipping boxes until needed.

Prior to starting assembly of the conveyor, carefully check the installation path to be sure there are no obstructions that will cause interference. Check for access along the path needed to bring in bed sections and components closest to the point where they are needed. It is often necessary to give the area along the system path a general cleanup to improve installation efficiency, access, and accuracy.

5.1 NBS PARTS INVENTORY & IDENTIFICATION

The following procedures are to be used as guidelines only. Specific installation methods will vary somewhat depending on available equipment on site and each installer's preferences based on past experience.

Each subassembly is shipped completely assembled except the bed joint splice plate/nuts which are shipped with other loose parts. Identify and separate the sorter subassemblies by type or tag number, for inventory and ease of locating during installation.



An identification label is attached to the inside of one side channel or on a crossmember, close to one end of each conveyor bed.

This label contains:

- Item number
- Description
- Job Number
- Mfg. Number
- Date of manufacture
- Tag number (if specified)
- Assembler's clock number
- QR (Quick Response) Label
 - Scan Code for IOM Manual



Scan the QR code to retrieve the IOM Manual, if nothing happens; check your scanner settings and make sure the QR Label setting is enabled.

On the supports, the tag is located on the bottom side of the foot. On special devices, it is located on a convenient flat surface that is not offensive to the appearance of the equipment but is still accessible for viewing. These numbers can be cross-referenced against the packing list. Loose parts are boxed and shipped separately.

You should have all conveyor sections and supports for a particular conveyor prior to installation. It is cost-effective to identify and procure any missing parts before they are needed for assembly. Small items like nuts and bolts are weigh-counted and packaged by size and type.

 **WARNING**



Hazard to Equipment or Personnel

- The Installation Supervisor must be experienced with conveyor, qualified in the mechanics of the equipment, and enforce safe working procedures for the protection of the crew, customer, and customer's property.
- Before restarting a conveyor, which has been stopped because of an emergency, an inspection of the conveyor must be made, and the cause of the stoppage determined. The starting device must be locked out before any attempt is made to correct the cause of stoppage.



Indicates a medium level potentially hazardous situation that, if not avoided, could result in death or serious injury.

6 NBS INSTALLATION DETAILS

General Procedures

The following procedures are to be used as guidelines only. Specific installation methods will vary somewhat depending on available equipment on site and each installer's preferences based on experience.

6.1 NBS GENERAL ELECTRICAL REQUIREMENTS

 WARNING	
	<p>Hazard to Equipment or Personnel</p> <ul style="list-style-type: none">• All electrical controls must be installed, wired, and connected by a licensed electrician only.• All motor controls and wiring must conform to the National Electrical Code as published by the National Fire Protection Association and approved by the American National Standards Institute, Inc. In addition, since specific electrical codes vary from one area to another, be sure to check with the proper authorities before starting the electrical wiring.• Do not connect the motor to any other voltage than stamped on its metal nameplate.
<p>Indicates a medium level potentially hazardous situation that, if not avoided, could result in death or serious injury.</p>	

The electrical voltage of the motor will be stamped on the metal nameplate. This voltage should be checked to see that it matches your available voltage. Many motors, both single phase, and three phase, are dual voltage. Consult the wiring diagram on the motor for the proper connections. If a three-phase motor on a single direction conveyor runs the wrong direction, two of the three leads must be switched to reverse rotation.



Consult the wiring diagram on the inside cover of the starter and push-button station for the proper electrical connections.

Three-phase drives require transformers to reduce the push-button and control circuit to 115 volts. If primary voltage is changed, the transformer must be changed according to the wiring diagram found on the transformer.

Note:

All control equipment is covered by the original manufacturer's equipment warranty.

NEMA type enclosure ratings are as follows:

 WARNING	
	<p>Hazard to Equipment or Personnel</p> <ul style="list-style-type: none">• All safety devices, including wiring of electrical safety devices, shall be arranged to operate in a “fail safe” manner. That is, if a power failure or failure of the device itself would occur, a hazardous condition must not result.• Do not connect the motor to any other voltage than stamped on its metal nameplate..
<p>Indicates a medium level potentially hazardous situation that, if not avoided, could result in death or serious injury.</p>	

NEMA 1 - Indoor use; Provides protection against contact with internal components. Suitable for use in warehouse and distribution environments.

Gasketed:

NEMA 1 - Same use as NEMA 1, but with additional protection against dust and dirt.

NEMA 3 - Outdoor use, designed to keep out rain and dust.

NEMA 4 - Indoor and outdoor use, designed to keep out rain and dust.

NEMA 12 - Indoor use: Provides protection against dust, dirt and oil, and drippings of noncorrosive liquids suitable for use in industrial environments.

NEMA 13 - Indoor use: Provides protection against dust, dirt, sprayed oil, and noncorrosive liquids.

6.2 NBS90 POLYSORT MHS CONVEYOR CONTROLS GUIDELINES

ECG 7.1

Rev. 1.6.03

(SEW-Eurodrive, 2018)[®] Motor Circuit Information

The SEW-Eurodrive MOVIMOT[®] is used in many high speed reversing (and non-reversing) applications, such as the transfer drive for the PolySort. The MOVIMOT[®] as provided by MHS would typically consist of the following:

- Three phase induction motor with an integrated variable frequency drive
- Speed control potentiometer, built into drive housing.
- Dynamic braking resistor, preinstalled in the drive.

Additional hardware required for control of the MOVIMOT[®] would include:

- Lockable, fused disconnect switch for each drive.
- Motor contactor for each system.
- 24V Control Power Supply
- 24VDC PLC output (PNP sourcing) for run command (two for reversing).

High Voltage Connections

- Verify that the motor nameplate rating matches the system voltage and frequency.
- Size fuses as for a conventional induction motor.
- Terminals for 3 phase power are located inside the connection box on the motor.
- Group motor installations are not permitted.
- A contactor before the fused disconnect switches must be used. This should be energized with the Master Control Relay (MCR) for the system and not used for normal motor stopping.
- Connect conductors to the L1, L2, L3 and ground terminals. See figure 1 below.

Controls Connections

- Connect dry contacts between the 24VDC and R[⌚] and/or L[⌚] terminals. These signals will start and stop the motor in the clockwise or counter-clockwise directions. See figure 1.
- Connect the external power to the 24V and ⊥ terminals. Connect PLC outputs to the R[⌚] and/or L[⌚] terminals (PNP sourcing outputs).

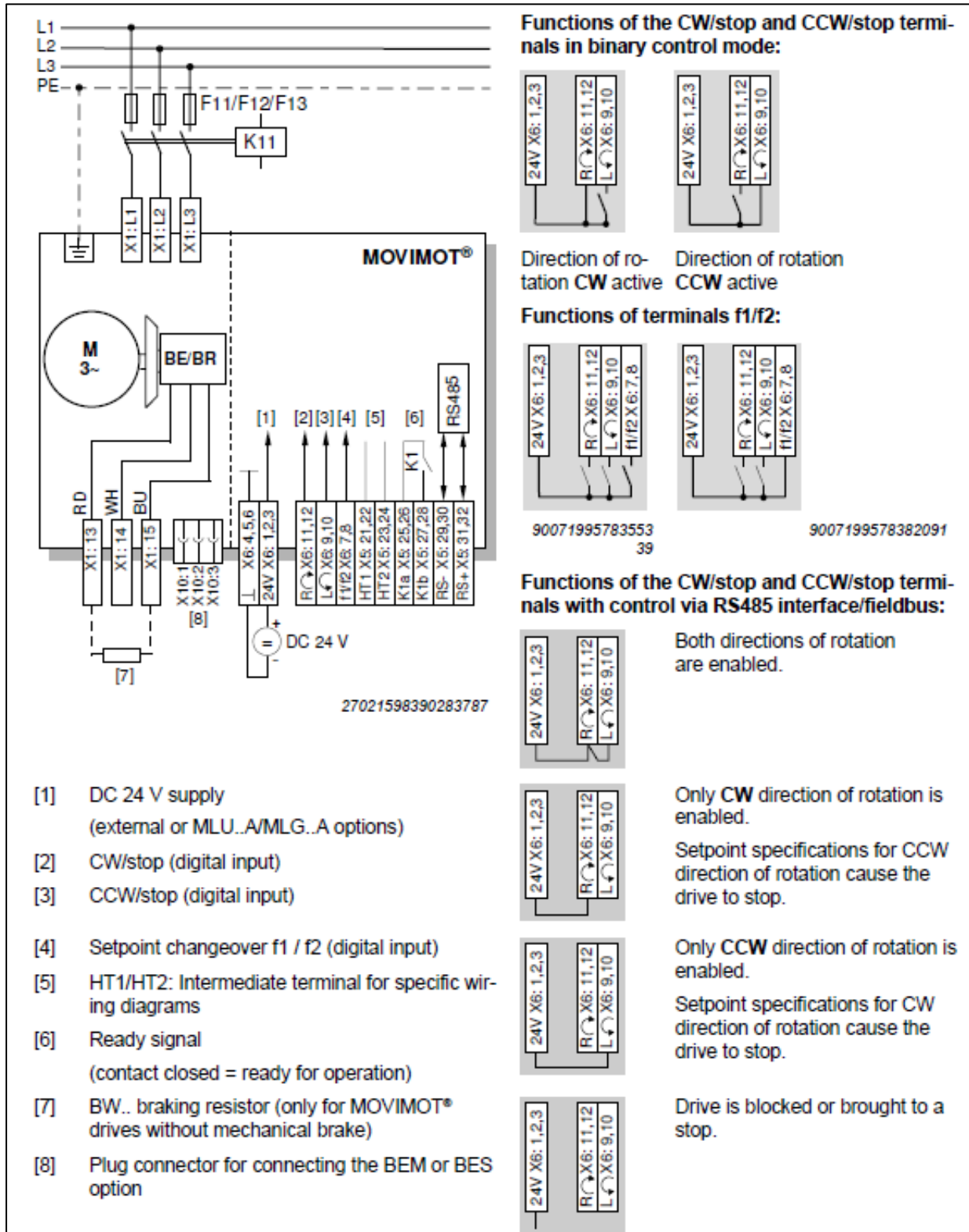

Speed, Ramp, and DIP Switch Settings

- The speed of the drive can be adjusted by turning the setpoint potentiometer, f1, accessible through a screw plug on the connection box cover.
- The ramp time is set with switch t1. Set this to detent position ‘0’ for maximum acceleration.
- DIP switch S1 should have all switches in the off position. (factory default) See figure 2.
- Setpoint switch f2 is not used and can be left at the factory setting.

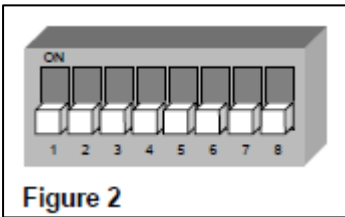

Status LED

A three-color status LED is visible on the outside of the connection box cover. The table below describes the function:

LED Color	LED Status	Operational Status	Description
-	Off	Not Ready	No 24V or System power
Yellow	Steady Flashing	Not Ready	Self-test phase active or 24V present but System power not OK
Yellow	Steady Light	Ready but unit inhibited	24V and System power OK, but no enable signal
Green	Steady Light	Unit enabled	Motor operating
Green	Steady, fast flashing	Current limit active	Drive has reached the current limit
Red	Steady Light	Not Ready	Check the 24V supply Make sure that there is a smoothing DC voltage with a low ripple (max 13%)
Red	2 x flash, pause	Fault 07	DC link voltage too high
Red	3 x flash, pause	Fault 11	Excessive temperature in output stage
Red	4 x flash, pause	Fault 84	Excessive temperature in motor Assignment of motor to frequency inverter incorrect
Red	5 x flash, pause	Fault 89	Excessive temperature in brake Assignment of motor to frequency inverter incorrect
Red	6 x flash, pause	Fault 06	Mains phase fault

6.2.1 NBS90 PolySort Sorter with Ethernet/IP comes pre-mounted from the factory.

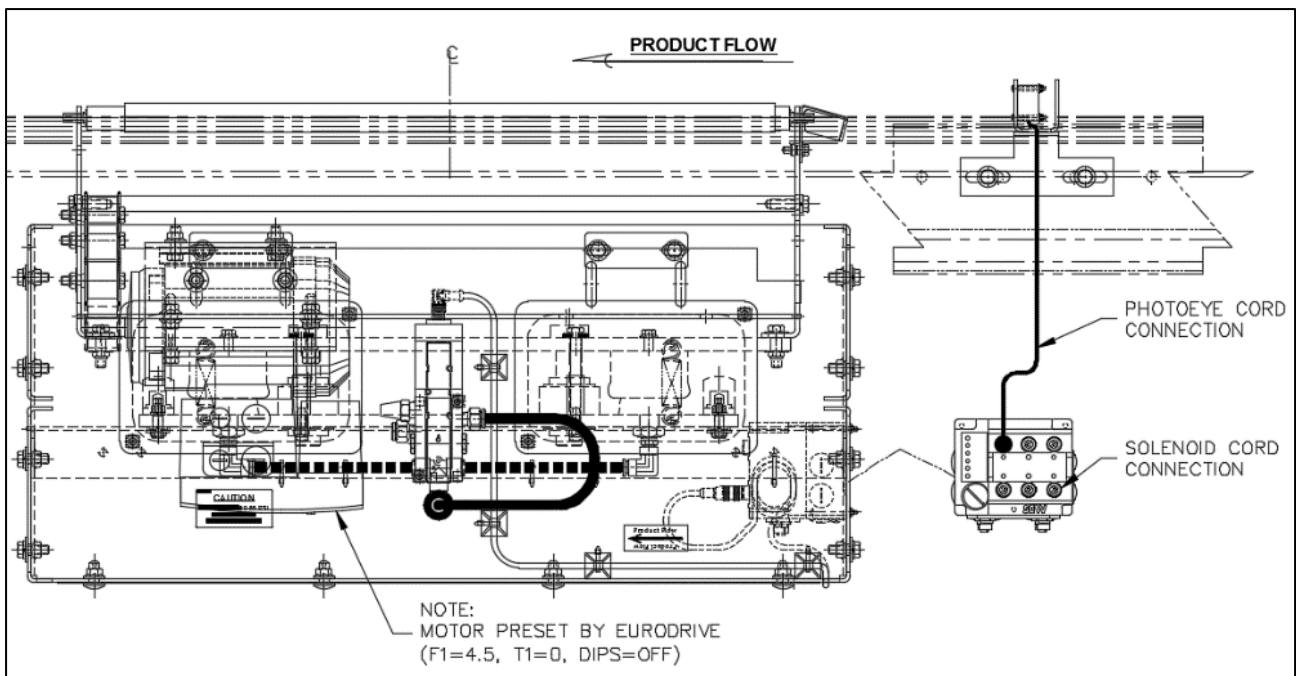
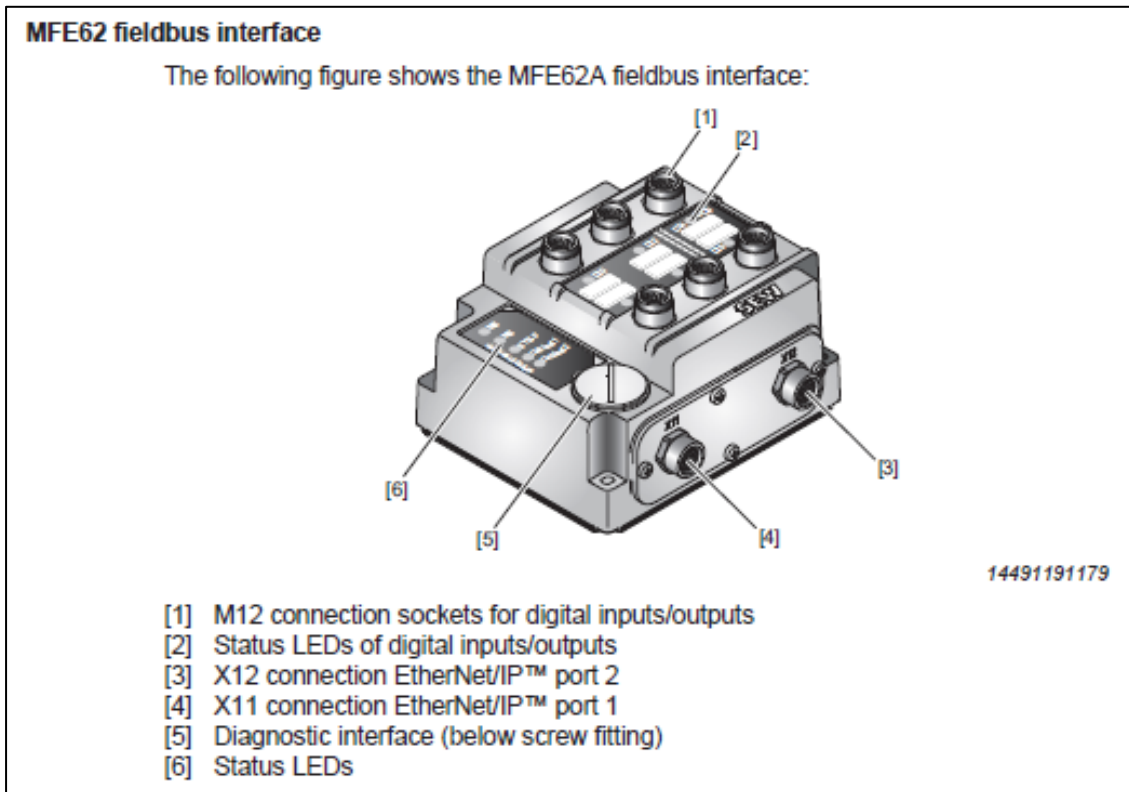

Connection of MFZ21 connection module with MFE62 to MOVIMOT®

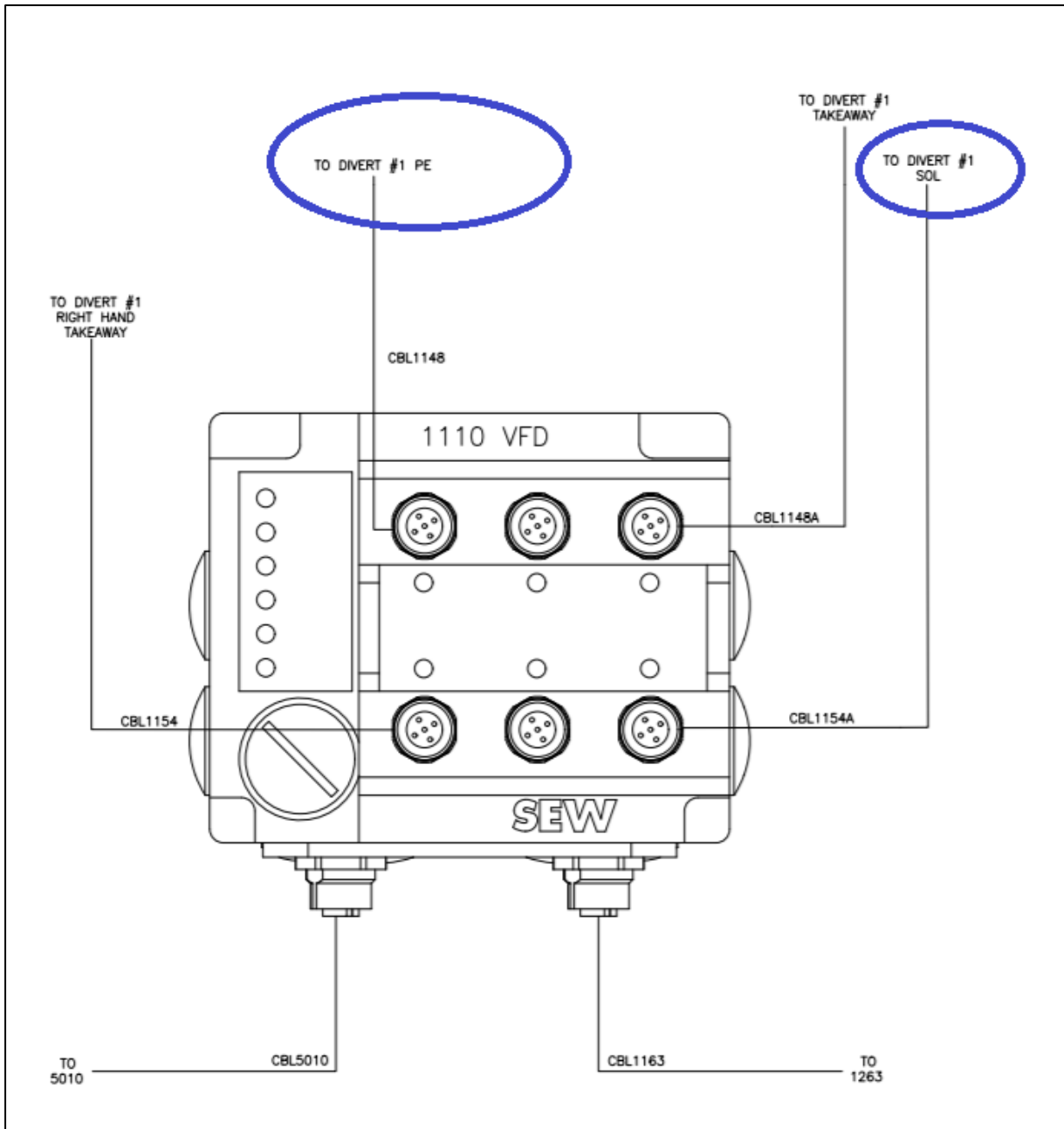

(Tri-Tronics, 2016)

MFZ21 connection module with MFE62 EtherNet/IP™ interface MOVIMOT®

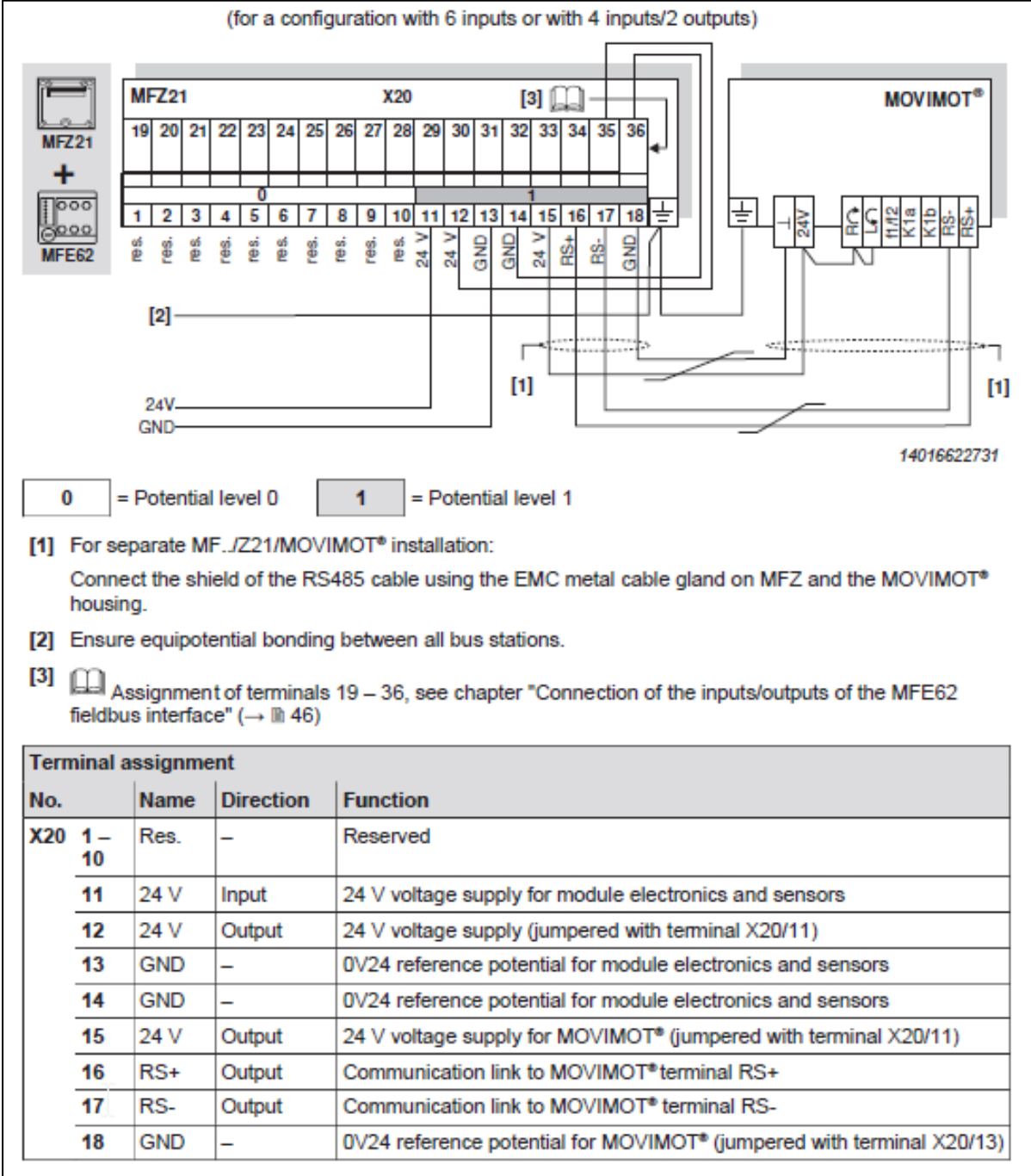

Note:

Communication cable between Movimot and MFZ21 is customer provided (Ref. Belden 88770 or similar.)

Divert #1 PE

LED Indication: Run Mode		
Power Indicator	Power present	
	No power	
Output Indicator	Not Blocked	
	Flash: Marginal	
	Blocked	
Light Bar	CTA Feedback (Continuous Threshold Adjustment Status)	



CTA Feedback
The space between the Blue LED's indicates the sensor can automatically make the amount of threshold adjustment. Illuminate when the sensor and reflector are in optimum working condition, the top and bottom LED with. As the sensor or reflector become dirty, the LED will get closer and closer together until the bottom two LED are illuminated. At this point, it is crucial that the sensor and/or reflector should be cleaned.

After cleaning, the LED will ill adjust back to the optimum working illumination indication.

Adjustment

1. Turn Output Indicator Pot Clockwise till it begins to flash
2. Adjust sensor to the reflector. Maximizing the light bar will indicate proper alignment
3. Turn Output Indicator Pot Counterclockwise till it stops flashing and is on Solid

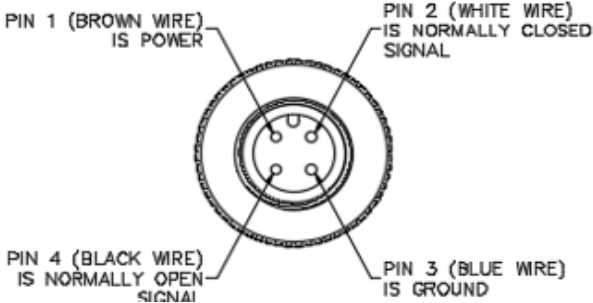
Note: The M12 Connector is field attached to the Photoeye see wiring diagram. See [NBS90 POLYSORT PHOTOEYE](#) in this IOM.

Divert #1 Sol

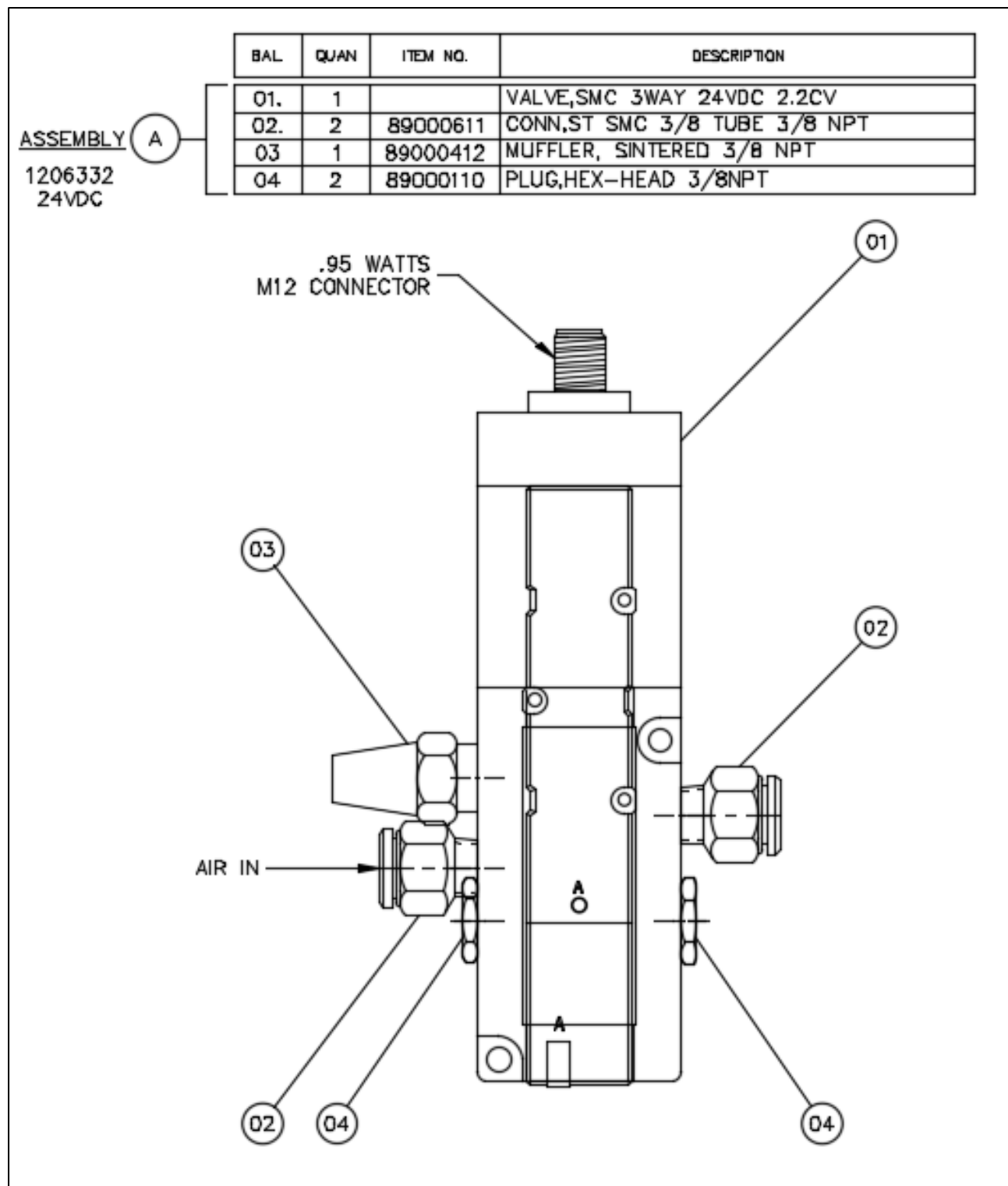

6.3 NBS GEAR MOTOR ACTIVATION

PRIOR to systems activation - Please inspect the gear unit for a vent and if **applicable to the product** remove the rubber sealing plug to activate. The vent is designed to allow excessive pressure to escape. Each gear unit should have a yellow instruction tag as shown below. The tag can be removed after the plug is removed.

Note: The rubber sealing plug is in place for shipping and storage purpose only.

! WARNING	
	<p>Hazard to Equipment or Personnel</p> <p>In order for the gear motor to release pressure, the vent must be activated by removing the rubber sealing plug PRIOR to gear unit start up.</p>
<p>Indicates a medium level potentially hazardous situation that, if not avoided, could result in death or serious injury.</p>	

Please check you gear unit for a vent and if applicable to your product, remove the sealing plug to activate. "<https://www5.nord.com>" Operation Manual for Gear Units (B1000).

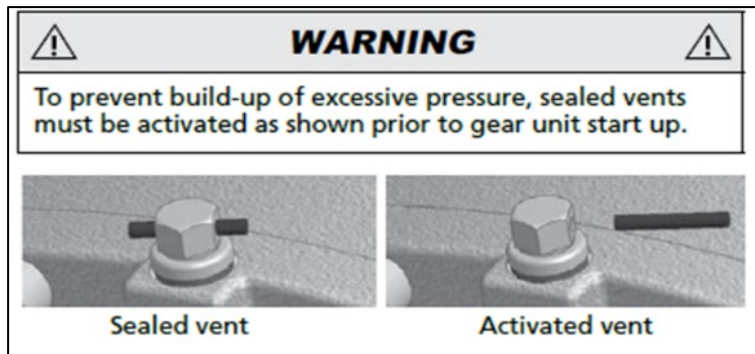

Note:

Yellow tags may be tucked out of sight. Please inspect all motors for a vent and remove sealing plug, if present, to activate.

The following pictures are examples showing where vent plugs may be located depending on the product line and motor position.

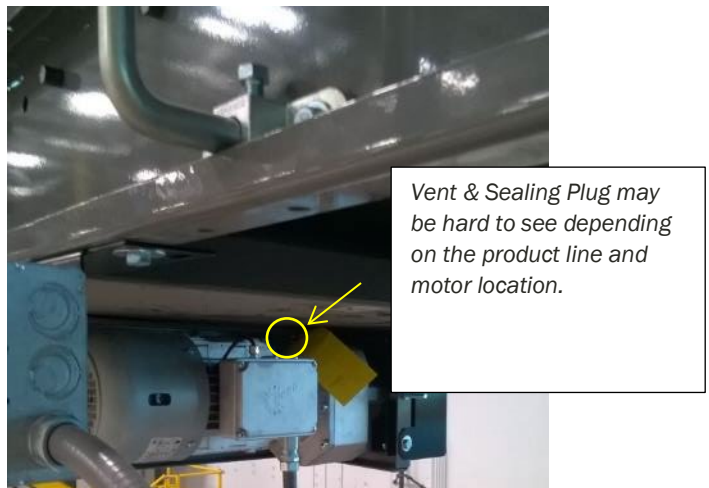
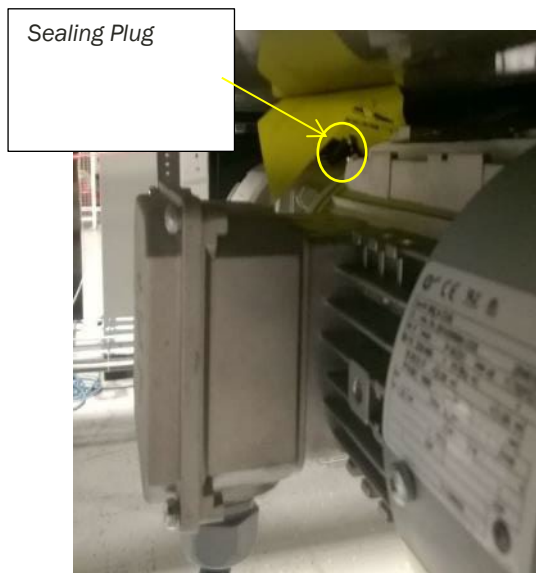
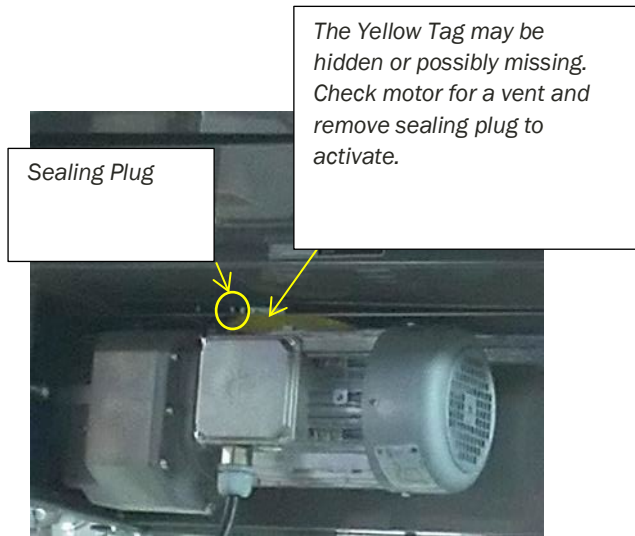



6.4 DIMENSIONAL REFERENCE POINTS

The path of each conveyor in the system is determined by establishing a reference point at each end. The centerline of the conveyor is established, and a chalk line is snapped between these points.

Conveyors should be installed with the centerline of the bed matching the centerline of the conveyor path within 1/16" of true center. Locate and mark the center of the crossmembers at each end of the conveyor. Use a plumb line or other applicable device to ensure accuracy to the chalk line.

Always carry out a thorough check for any obstructions such as building columns, manholes, etc. It may be necessary to reroute the conveyor to avoid the obstruction. In this case it would be advisable to begin installation at this point, using the obstruction as a reference point (Datum), and install the sections in either direction as required.

All conveyor sections must be checked for squareness prior to installation as "racking" or being knocked out of square may have occurred during shipping and handling.

 WARNING	
	<p>Hazard to Equipment or Personnel</p> <ul style="list-style-type: none">• The Installation Supervisor must be experienced with conveyor, qualified in the mechanics of the equipment, and enforce safe working procedures for the protection of the crew, customer, and customer's property.• Before restarting a conveyor, which has been stopped because of an emergency, an inspection of the conveyor must be made, and the cause of the stoppage determined. The starting device must be locked out before any attempt is made to correct the cause of stoppage.
<p>Indicates a medium level potentially hazardous situation that, if not avoided, could result in death or serious injury.</p>	



6.5 NBS ELEVATIONS

All top-of-belt (TOB) heights should be installed in accordance with the elevations shown on the drawings. In addition, all sortation devices must be level across both the frame width and length. Leveling of the frames is best done using a rotating laser level along the length of the conveyor and a builder's level across the width.

After the first elevation is established at a critical point, the elevation of all other points shall be relative to this first point. Normal practice is to dimension the layout and measure elevations from the floor at each point of support.

As the conveyor system proceeds onto another floor or into another building or room, a new elevation will be measured from the floor at that point. This new elevation will then become the reference for subsequent elevations.

When installing an overhead system, the first elevation is measured from the floor and becomes the reference elevation point until a change in elevation is shown on the layout. Any new elevation is also measured from the floor and becomes the new reference point. The process is repeated each time an elevation change occurs.

 CAUTION	
	<p>Hazard of Equipment</p> <p>Consult the building architect or a structural engineer regarding ceiling loading or structural limitations of the building if any conveyor is ceiling hung.</p>
<p>Indicates a low level potentially hazardous situation which, if not avoided, could result in minor or moderate injury. It may also be used to alert against unsafe practices or for the protection of the equipment.</p>	

6.6 NBS SUPPORTING ARRANGEMENT

Floor Supports

Install bolts used to attach the standhead to the frame so the nut is on the bottom. Standhead bolts should be left finger tight while the conveyor is being assembled and aligned.

Floor supports are ordered by nominal height range, which is the dimension from the floor to top of the support. Conveyor elevations are shown on the layout by top-of-belt elevations. The difference between top of belt (TOB) and top of support is 7-3/8" and 9-5/16" end pulley and 13 1/16" direct drive bed. This dimension must be subtracted from the TOB height to set support height.

It is important that conveyor frames be installed level. Floor supports will accommodate normal irregularities in the floor surface. Adjustment for elevation in floor supports is accomplished with metal-on-metal bolt clamping force. To achieve the support's stated load rating, it is necessary to tighten the elevation adjustment bolts (3/8" diameter) to 23 ft. /lbs. of torque.

Supports should always be installed in the vertical position, and any variations due to conveyor pitch or floor slope will be compensated for in the pivoting stand-head of the support.



6.7 NBS SUPPORTS & CONNECTIONS

For details on Supports & Connections, see Support & Connections IOM (#1200485) at <https://www.mhs-conveyor.com/support/iom-manuals/supports-and-connections>

Anchoring

Anchoring in concrete floors is accomplished by drilling into the floor and inserting the suitable anchor bolt. The hole diameter and depth must be in accordance with the anchor bolt manufacturer’s instructions, and all applicable codes and requirements.

Anchor intermediate floor supports with two anchor bolts, one through each support foot plate using minimum 3/8” diameter anchor bolts. Stagger anchors from front hole on one side to rear hole on opposite side. For floor supports, over 5’ minimum use 1/2” diameter anchor bolts. Anchor bolts for equipment subject to impact loads should be a minimum of 1/2” diameter or as superseded by any other applicable code.

 WARNING	
	<p>Hazard to Equipment or Personnel</p> <p>Place a bolt through the frame and support immediately with finger tight the nut. This will prevent the frame from falling off the support, if bumped, and causing injury.</p>
<p>Indicates a medium level potentially hazardous situation that, if not avoided, could result in death or serious injury.</p>	

Bed/Support Connectors

NBS can **ONLY** be supported at bed joints. Install the sortation conveyor (drive bed thru end pulley) on supports. Leave approximately 1/16” gap between low friction rail joints. The conveyor must be level and straight. Adjoining beds are connected using 3/8” thick by 10” nut plate, 3/16” thick by 10” clamping plate and 3/8” hardware. These parts are shipped with other loose parts. Insert 10” nut plate halfway into the formed channel end of each bed.

Mount standhead support with two 3/8-16 x 1” hex head bolts with flat and lock washers. After that mount 10” clamp plate to channel ends with four 3/8-16 x 1” hex head bolts with nut, flat and lock washers (see picture below). It can be seen that a crossmember could be moved into the recessed area of the standhead support bracket if needed.

Maintaining the rigidity and flatness of the conveying surface is the end result of proper support installation.

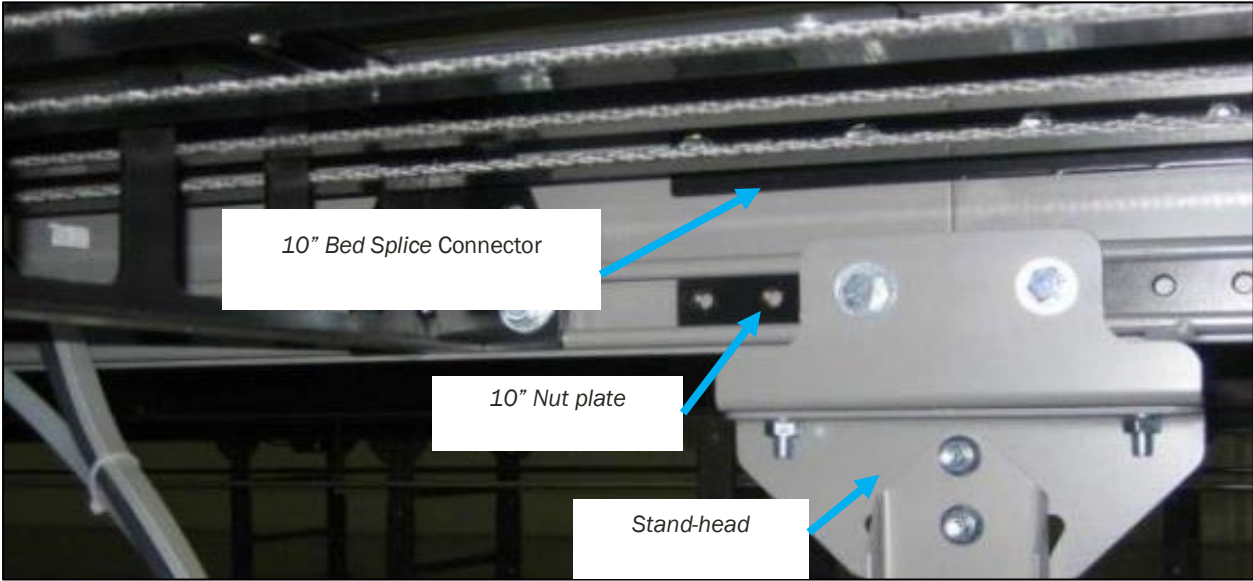

6.8 NBS90 POLYSORT BED CONNECTION KIT

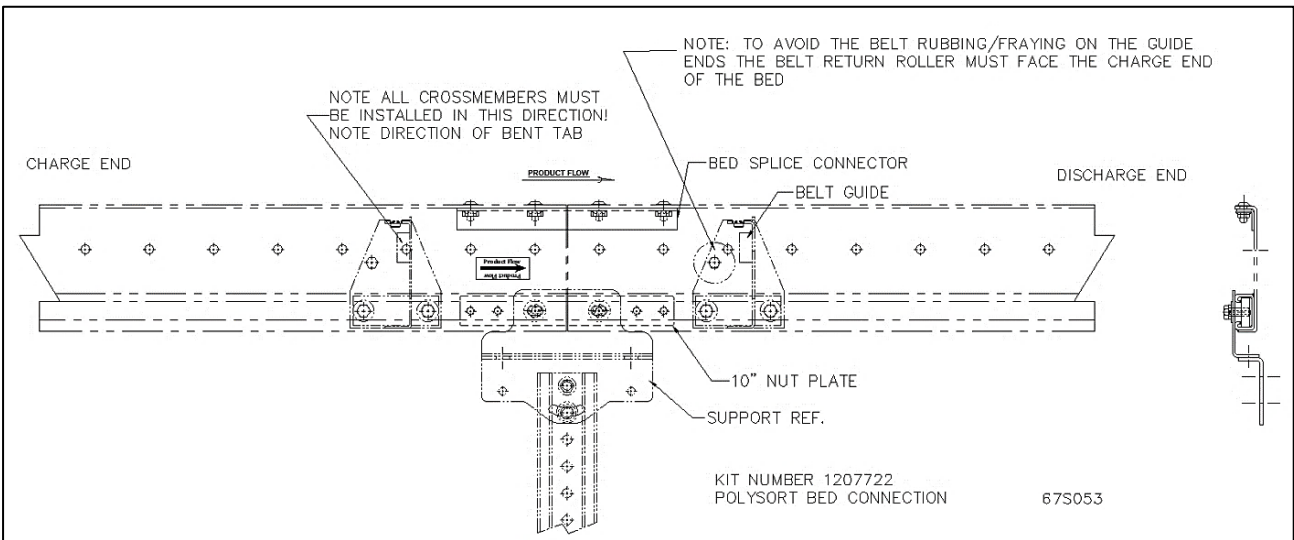

Bed Splice Connection Kit MHS # 1207722

! CAUTION	
	<p>Hazard of Equipment</p> <p>Avoid the belt rubbing/fraying on the guide ends the belt return roller must face the charge end of the bed.</p>
<p>Indicates a low level potentially hazardous situation which, if not avoided, could result in minor or moderate injury. It may also be used to alert against unsafe practices or for the protection of the equipment.</p>	

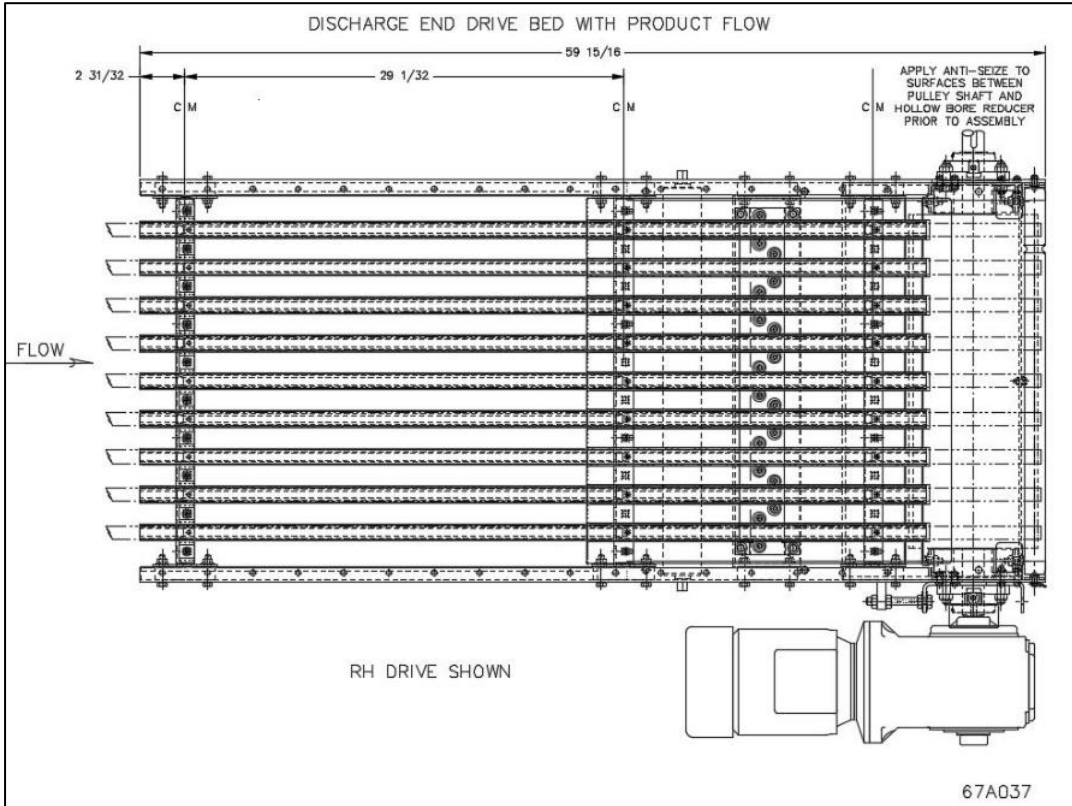

6.9 NBS90 POLYSORT COMPONENT ORIENTATION



Using your conveyor system layout drawing and the numbers on the I.D. tags on each component, position and orients the conveyor sections.

You must know:

- The direction of product flow
- The elevation height
- The drive is positioned at the discharge end
- The end pulley is positioned at the charge end
- Ensure rails are aligned and snag free

 WARNING	
	<p>Hazard to Equipment or Personnel</p> <p>Do not make alterations to the equipment without consulting with the user’s representative and MHS Conveyor. Unauthorized modifications to the equipment may impair its function, create a hazardous condition, affect its useful life, and/or void the warranty.</p>
<p>Indicates a medium level potentially hazardous situation that, if not avoided, could result in death or serious injury.</p>	

6.10 NBS90 POLYSORT TRANSFER GENERAL LAYOUT

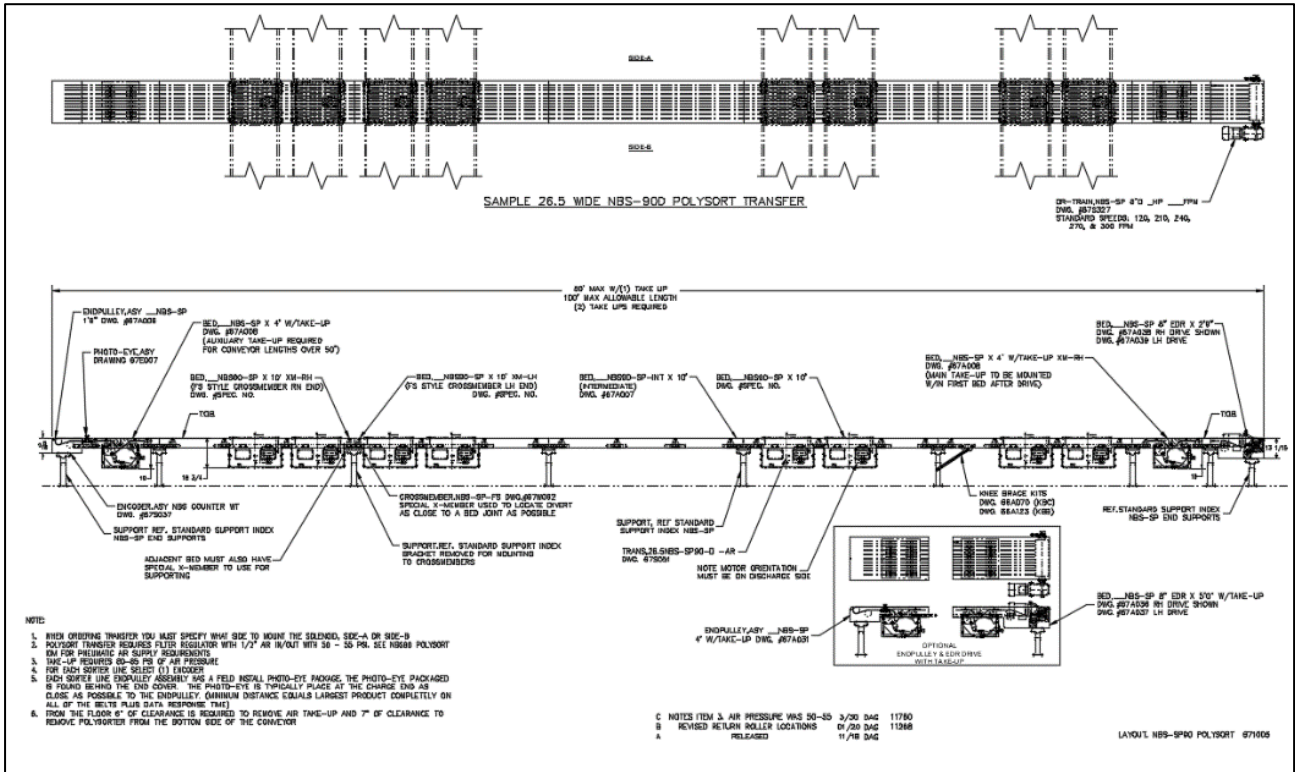

General Layout, 26.5 Wide NBS-90D PolySort Transfer

6.11 NBS90 POLYSORT PHOTOEYE

Retroreflective photoeye Ray 10

Adjust the retroreflective type as follows:

- Determine what sizes of target the photoeye must sense.
- Adjust for the worst case, usually smallest item, by loosening photoeye mounting nut and aligning while making sure photoeye has unobstructed view of reflector.
- Move the target in and out of the field of detection to ensure that the photoeye energizes and de-energizes.

Adjust the photoeye type as follows:

- Loosen photoeye switch mounting bolt and adjust photoeye so that the product passes directly in front of the switch face, as close to the switch face as possible without making contact.
- Check that the photoeye energizes and de-energizes as the product passes in front of the eye's face.
- Tighten the mounting bolt.

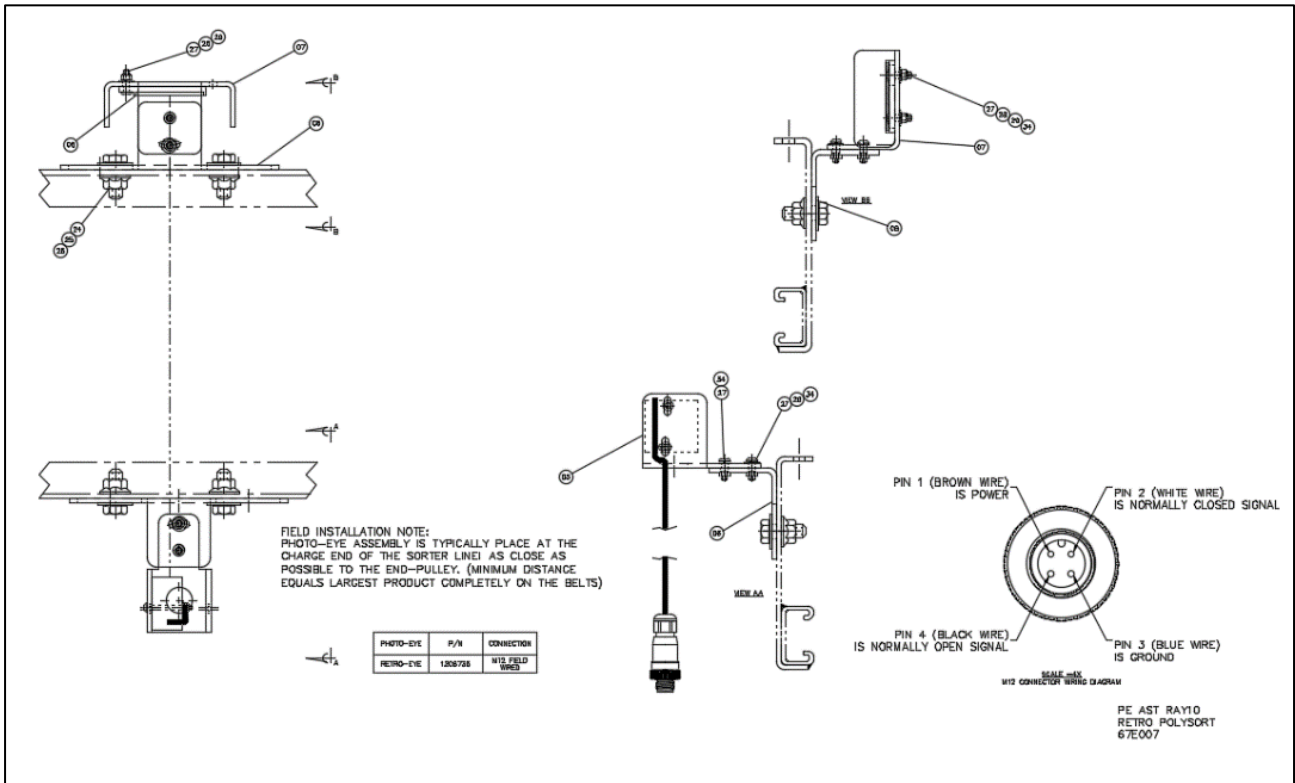

PE, ASY, RAY10 RETRO - POLYSORT	
Description	Item #
PE, ASY, RAY10 RETRO	1206735
PHOTOEYE, RETO RAY10- CONN TYPE PIGTAIL	1214548
CONN, FIELD-WIREABLE, M12 MALE	1214615

6.12 NBS90 POLYSORT CEILING SUPPORTED

The NBS90 PolySort conveyor is designed to ALWAYS be supported at the bed joints. For ceiling hanging applications, an NBS90 PolySort ceiling hanger kit MUST be used at the bed joints as shown in the diagrams below. The end pulley and drive beds show connection locations for the specific ceiling hanger kit designed for those locations. Along with the ceiling hangers, cross bracing is required for all hangers. This ceiling hanging method provides the lateral conveyor rigidity.

Deviation from this ceiling hanging requirement will void the warranty of the NBS90 PolySort.

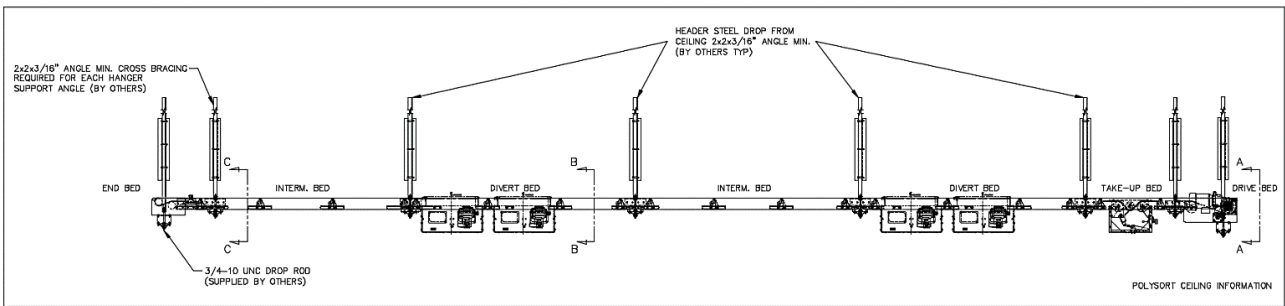

CAUTION	
	<p>Hazard of Equipment</p> <p>Deviation from this ceiling hanging requirement will void the warranty of the NBS90 PolySort.</p>
<p>Indicates a low level potentially hazardous situation which, if not avoided, could result in minor or moderate injury. It may also be used to alert against unsafe practices or for the protection of the equipment.</p>	

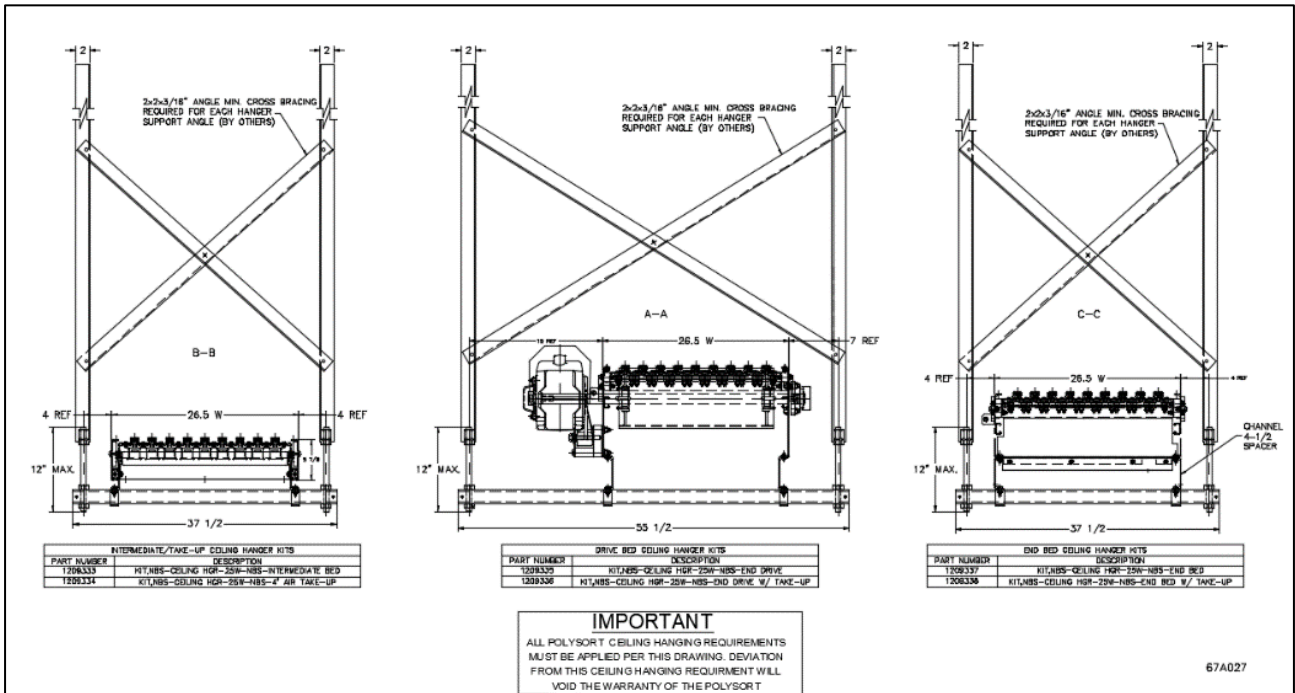

Ceiling hanger diagrams are a guide to establish a final support design.

Consult structural engineer for actual application.

! WARNING

Hazard to Equipment or Personnel

Consult a structural engineer for an actual application.

Indicates a medium level potentially hazardous situation that, if not avoided, could result in death or serious injury.

6.13 NBS ALUMINUM EXTRUSION T-NUT CONNECTORS

The aluminum extrusions that hold the UHMW belt guides are installed at the factory. The triple T-nut connectors are mounted, at the factory, flush with the ends of the aluminum extrusions on the discharge side of all NBS bed assemblies. These triple nut connectors should be extended half-way out of the extrusions before "plugging in" the next bed downstream during installation. After all bed components are installed, leveled, and straightened the 5/16-18 hex head bolts used in the triple T-nut connectors should all be loosened, to straighten the aluminum extrusion joints and re-tightened.

Note:

Ensure rails are aligned and snag free.

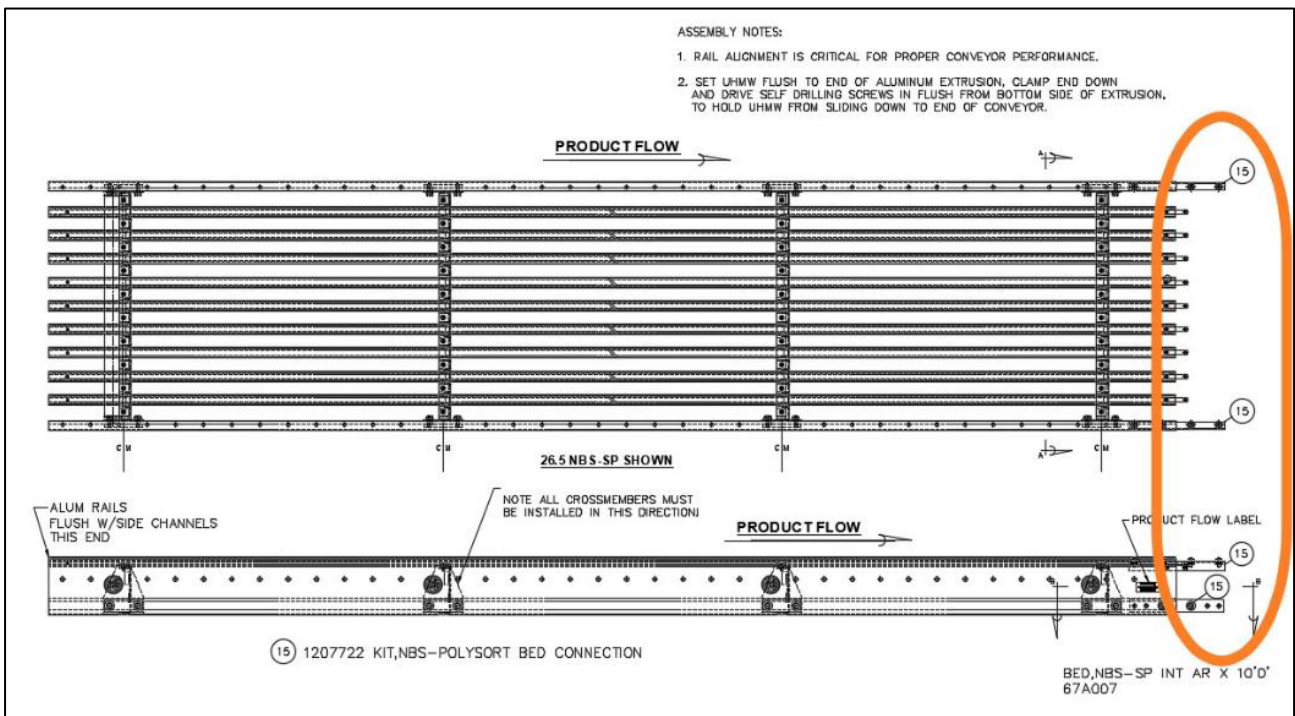

6.14 NBS BELT INSTALLATION

Pre-installation

Belts, as shipped from MHS Conveyor, are cut to length with lacing installed. Rolls of belting should be stored on edge on a pallet. Never leave a belt where it may absorb moisture. Remove any tight shipping banding immediately upon arrival. Lacing pins are taped inside the lacing on each belt.

The NBS90 PolySort conveyor should be completely installed and aligned before belt installation.

Remove the plexiglass side covers from the sides of the auxiliary belt take-up frame, exposing the take-up pulleys. Switch the take-up air switch to the un-tensioned position, raising the take-up pulleys to the minimum take-up position.

Belt Threading

Because NBS uses multiple narrow belts of long length, it will be most efficient to have two people working together during the threading process.

The belting must be uncoiled and laid out flat on the sorter, with the smooth black carrying surface up. The belts must not be allowed to twist along their length as they are installed. Start at the charge end (farthest from the drive) and feed all of the belts through together at the same time. Start the belts down between the gap roller and the end pulley. Guide the belts under the 4" diameter end pulley and up and over the 4" diameter snub pulley, before passing through the belt guide wheels.



All belts must pass over any return rollers positioned to minimize belt sag and through holes in crossmembers.

The black PVC surface of the belt should be up and the rough surface rides in the UHMW tracks.

Mesh the loops of the lacing on one end of the belt with the loops on the other, so the sides of the belt are even, and install the lacing pin.

Belt Tracking

With the belts tensioned, "bump" the motor to be sure rotation is correct, the belts are running smoothly and maintaining their position. Most NBS90 PolySort conveyors do not require belt tracking. However, each conveyor should be checked at the charge and discharge ends to be sure the belts are floating in a neutral position not crowding the sides of the UHMW guide tracks. If the belts are out of their grooves or riding hard to one side fine adjustments can be made on the driven pulley jackscrew, at the discharge end.

Reinstall the bottom pan on the end pulley assembly and access covers on the auxiliary belt take-up.

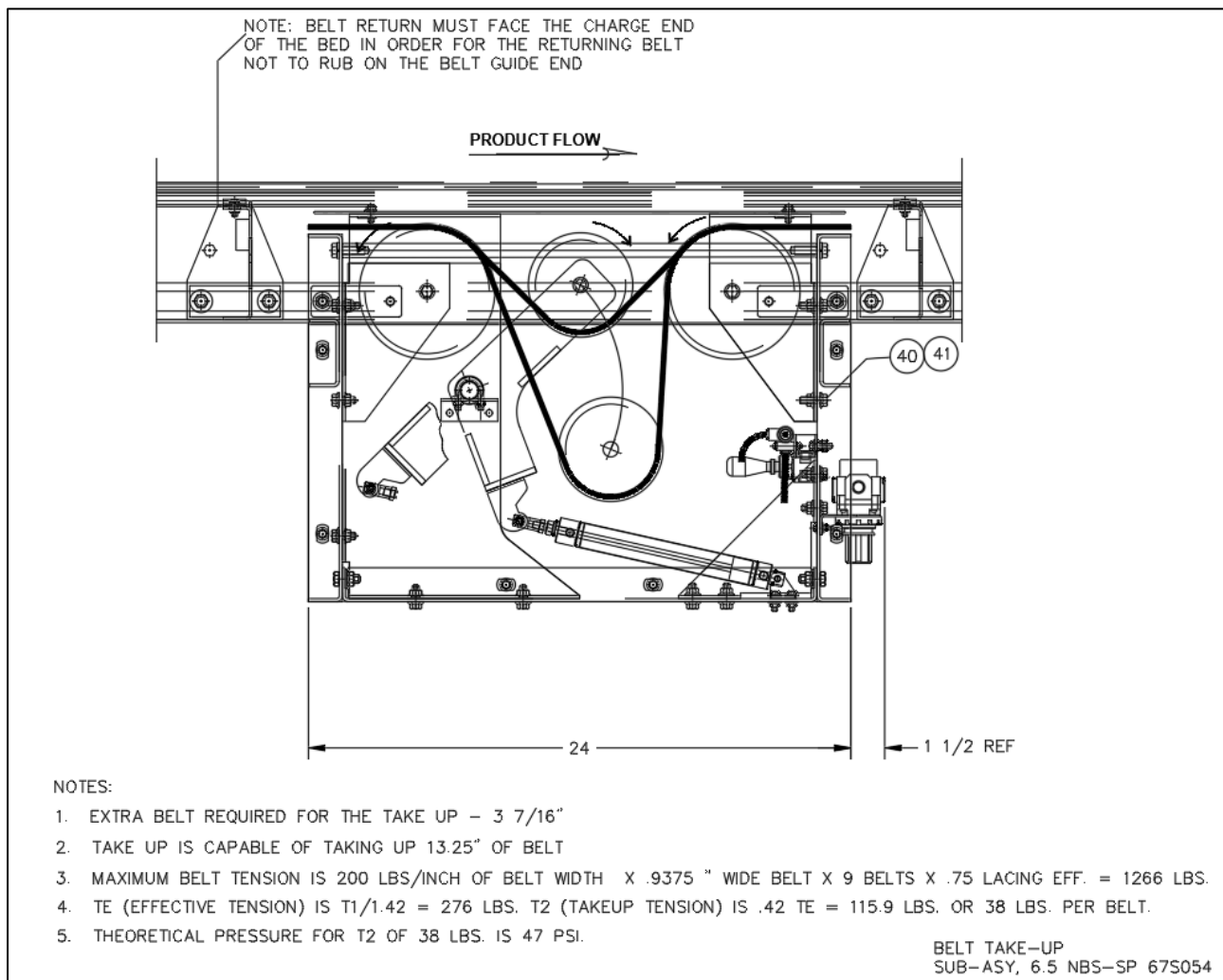

CAUTION	
	<p>Hazard of Equipment</p> <p>As shown above: To avoid the belt rubbing/fraying on the guide ends the belt return roller must face the charge end of the bed.</p>
<p>Indicates a low level potentially hazardous situation which, if not avoided, could result in minor or moderate injury. It may also be used to alert against unsafe practices or for the protection of the equipment.</p>	

6.15 NBS BELT SPECIFICATIONS AND LACING

- PVC 200 belt
- Width: 15/16" +/- 1/32"
- Thickness: .203" +/- .015 thick, with a recessed
- Thickness at recess: .125" to .156"
- Lace: Clipper P/N 05265 U2S12 (tote); minimum number of hooks = 5 on one end, 6 on the other end.
- Lacing Pin: Nylostainless
- .093 dia. x 7/8" +/- 1/32" long (316 stainless steel w/nylon coating); clipper P/N 02670
- For field repair chamfer belt corners, no more than 1/8".



⚠ CAUTION	
	<p>Hazard of Equipment</p> <p>Only use the specified lacing and pin. Any substitution will result in premature belt failure.</p>
<p>Indicates a low level potentially hazardous situation which, if not avoided, could result in minor or moderate injury. It may also be used to alert against unsafe practices or for the protection of the equipment.</p>	

6.15.1 NBS-90 PolySort Belt Replacement

Replacement belts may be ordered by the original "P/N" part number marked on the belt or belt length can be determined by the following information.

- 2'-9" drive bed = 5'11-1/4" (71.25")
- 5'0" Drive bed with take-up = 10'8-9/16" (128.5625")
- 1'6" End Pulley = 2'11-3/8" (35.38")
- 4'0" End Pulley with take-up = 8'2-13/16" (98.8125")
- NBS90 PolySort transfers require 0" each
- Take-up = 3-7/16" (3.4375")
- All other beds require 2 times their overall length.

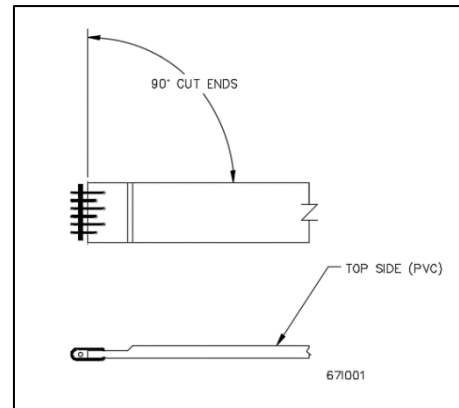

NOMINAL WIDTHS (# OF BELTS)

- 26.5BF with 9 belts on 2 1/2" centers

6.16 NBS PNEUMATIC GENERAL GUIDELINES

General

Suggested requirements for NBS sorter and diverts



Every conveyor system is unique, with its own specific requirements. Therefore, the following is a general guide.

MAIN FEEDER: Air velocity through the main feeder piping can be kept smooth with lower losses using large diameter pipe with minimum bends and restrictions. Standard weight black pipe or copper is suitable for plumbing the compressed air overhead to all points of use.

AIR DROPS: MHS Conveyor recommends using 3/4" pipe on air drops for high flow and low pressure loss. The drop is terminated with a drain at the bottom. A tee located prior to the drain branches off to the conveyor. This branch line must contain a lockout/shutoff. A shutoff must also be located in the drop before the branch tee. OSHA Rule 29, CFR1910.147 requires energy sources (air drops) be turned off and capable of being locked or labeled with a warning tag.

Note: NBS pneumatic systems does not require lubrication. Lubrication may affect the valving operation and cause sluggish or erratic operation.

Important: If your air compressor uses synthetic oil, a coalescing filter plus a regular filter of 5 micron is required. Synthetic oils will shrink the seals in pneumatic devices and valving.

 CAUTION	
	<p>Hazard of Equipment</p> <p>All air lines must be thoroughly blown out (of all debris) and the regulator must be set as required before connecting air to the NBS.</p>
<p>Indicates a low level potentially hazardous situation which, if not avoided, could result in minor or moderate injury. It may also be used to alert against unsafe practices or for the protection of the equipment.</p>	

6.17 NBS90 POLYSORT PNEUMATIC

Every conveyor system is unique, with its own specific requirements. Therefore, the following is a general guide.

Main Feeder



Air velocity through the main feeder piping can be kept smooth with lower losses using large diameter pipe with minimum bends and restrictions. Standard weight black pipe or copper is suitable for plumbing the compressed air overhead to all points of use.

Air Drops (NBS90 PolySort)

MHS Conveyor recommends using 3/4" pipe on air drops for high flow and low pressure loss. The drop is terminated with a drain at the bottom. A tee located prior to the drain branches off to the conveyor. This branch line must contain a lockout/shutoff. A shutoff must also be located in the drop before the branch tee. OSHA Rule 29, CFR1910.147 requires energy sources (air drops) be turned off and capable of being locked or labeled with a warning tag.

NOTE: The NBS90 PolySort and SP pneumatic system does not require lubrication. Lubrication may affect valve action and cause sluggish or erratic operation.

IMPORTANT! If your air compressor uses synthetic oil, a coalescing filter plus a regular filter of 5 micron is required. Synthetic oils will shrink the seals in pneumatic devices and valves.

 CAUTION	
	<p>Hazard of Equipment</p> <ul style="list-style-type: none">• All air lines must be thoroughly blown out (of all debris) and the regulator must be set as required before connecting air to the NBS.• NBS90 PolySort diverters must not be operated above 55 PSI. Exceeding this may damage unit.
<p>Indicates a low level potentially hazardous situation which, if not avoided, could result in minor or moderate injury. It may also be used to alert against unsafe practices or for the protection of the equipment.</p>	

6.18 NBS90 POLYSORT AIR TAKE-UP DIAGRAM

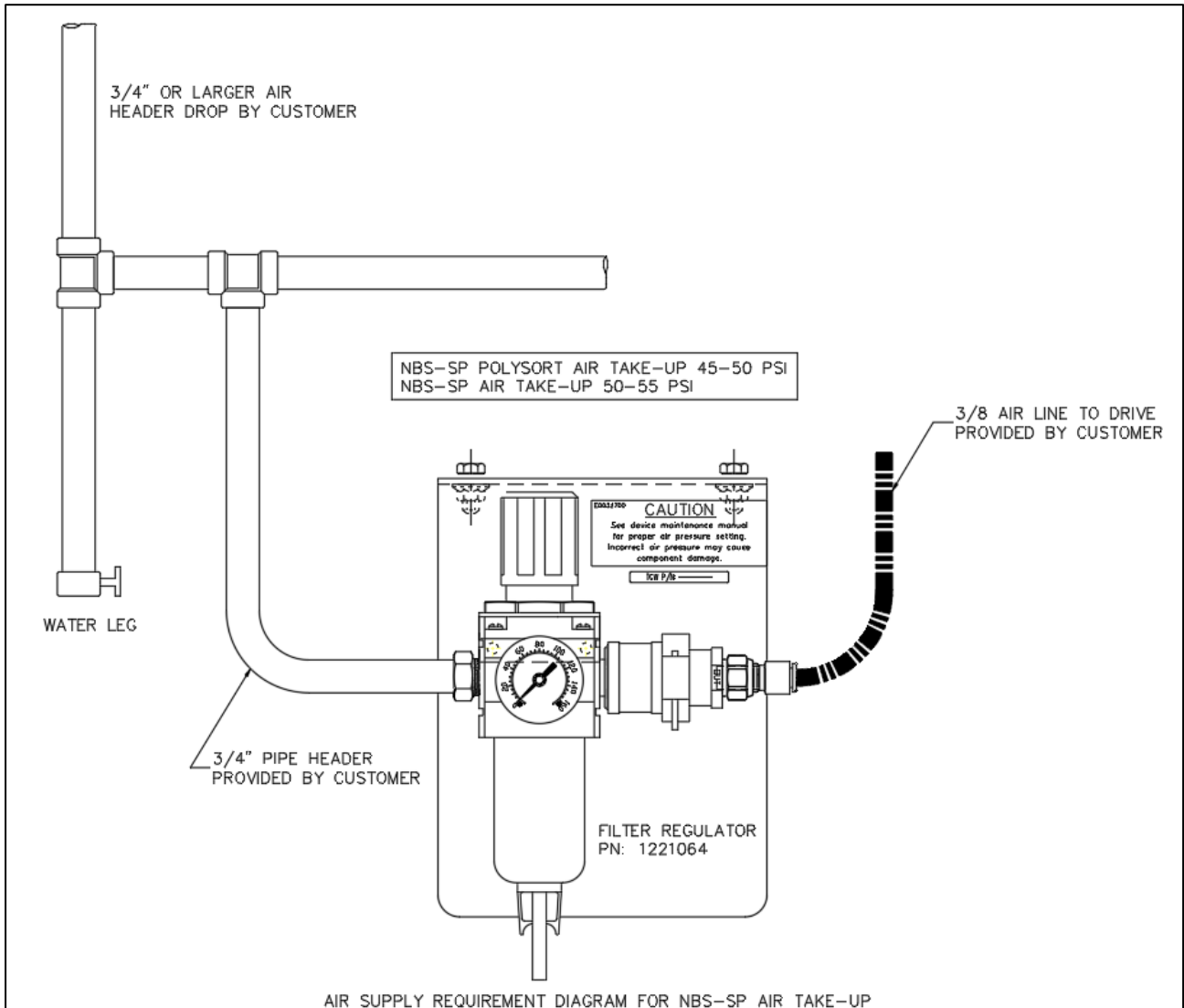

6.19 NBS90 POLYSORT AIR TRANSFER DIAGRAM

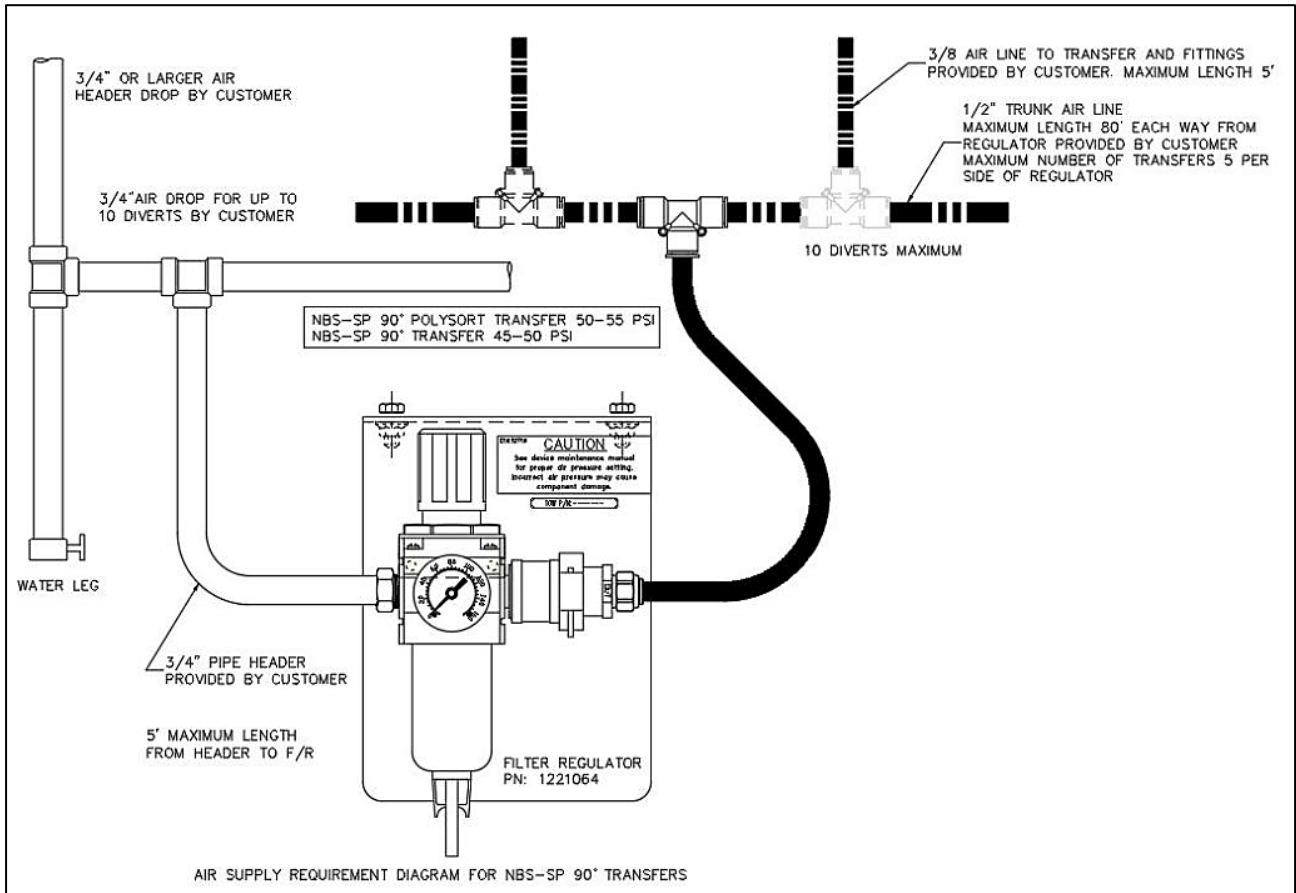

6.21 NBS90 POLYSORT AIR LINE CONNECTIONS

Source Air Connection

Select the best position along the conveyor to connect the source air from a drop line. Ideally, the regulator should be centrally located along the sorter and should not be more than 80' from the furthest diverter/transfer or drive.

Attach the filter/regulator assembly to the bottom flange of the side frame using the mounting bracket supplied with the kit.

The source airline that distributes air to the diverters/transfers should be 1/2" hose that is rated to handle a pulsating 60psi line pressure. MHS Conveyor part number 89000572 TUBING, URETHANE 1/2 OD is available for this purpose.



Cut into the supply line along the sorter bed and install the source airline tee fitting MHS Conveyor part number 89000640. Connect the source air line between this fitting and the filter/regulator output.

The hose size at each diverter/transfer is 3/8 OD and the source airline can be tapped at each location using MHS Conveyor part number 89000640 1/2" tee and 1/2" x 3/8" tube reducer fitting MHS Conveyor part number 1155149.

Low Pressure Air Switch

The installation of an air pressure switch in the NBS air supply circuit, to detect a drop in air pressure below required levels, is recommended. If pressure drops below approximately 40 PSI, the conveyor system should shut off.

It is recommended that this air switch be located either at the furthest end of the source air line away from the regulator or at the pneumatic belt take-up located in or near the drive bed at the discharge end of the sorter.

 CAUTION	
	<p>Hazard of Equipment</p> <ul style="list-style-type: none">• Do not use a lubricator. When replacing filter/regulator bowl, lightly lubricate seal with mineral oil. Do not use synthetic oils such as esters or silicones. DO NOT get oil inside filter/regulator bowl.• The function of the low pressure air switch is to protect the drive pulley and the NBS narrow belts from being damaged from slipping under load in the event of an air pressure disruption. Loss of air pressure may also cause diverter / transfer jams.
<p>Indicates a low level potentially hazardous situation which, if not avoided, could result in minor or moderate injury. It may also be used to alert against unsafe practices or for the protection of the equipment.</p>	

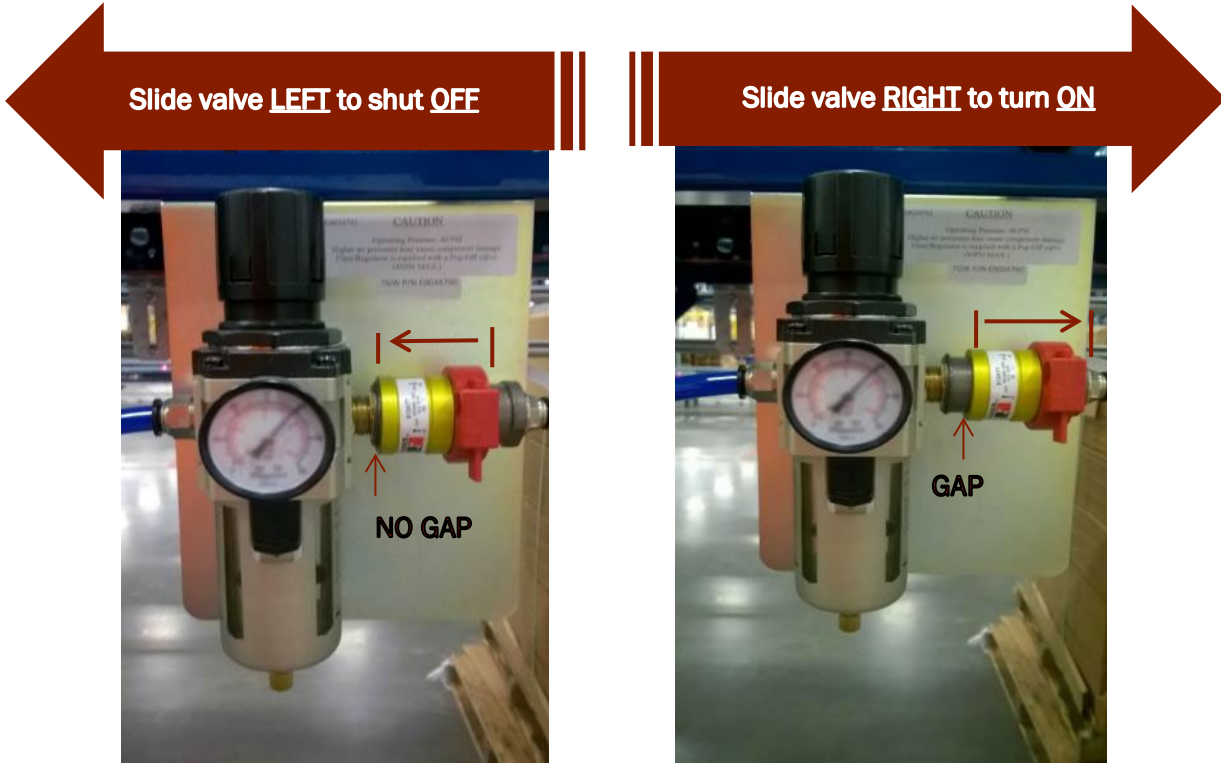

6.22 NBS AIR REGULATOR LOCK OUT VALVE ON AND OFF POSITION



Note:

The air regulator valve label details the on and off positions.

For air pressure regulations please see detailed instructions in this manual.

 WARNING	
	<p>Hazard to Equipment or Personnel</p> <p>Do not remove and install sleeve valve to infeed side of regulator. Back feeding through the regulator will cause damage and void the warranty.</p>
<p>Indicates a medium level potentially hazardous situation that, if not avoided, could result in death or serious injury.</p>	

6.23 NBS COMMISSIONING OF EQUIPMENT

General

Commissioning of the equipment can best be defined as the final adjustments and test of the installed equipment required for its proper operation. The need for commissioning is inherent since the individual components of equipment are brought together at the installation site to operate as a system.

Mechanical and electrical commissioning are most often carried out simultaneously. Commissioning must simulate the actual operation of the system as closely as possible to demonstrate the ability to perform reliably at the specified rate in the prescribed operational sequence.

During the Commissioning Phase, it is necessary to load the equipment with product to be conveyed, which provides the means of detecting those areas requiring adjustment. Personnel will be required to support operational functions. This may serve as part of operator training and familiarity with the system. During the commissioning activity, special attention should be directed toward personnel safety. No unnecessary risks should be taken that would endanger the safety of any personnel. All personnel must familiarize themselves with all safety features of the system such as emergency stops and motor disconnects.

6.23.1 Mechanical Static Checkout



(No power to the conveyor.)

- The belt tension and air pressure must be set to the correct pressure setting, which is dependent on sorter width. Air pressure higher than required can cause belt failure.
- Listen for air leaks after air pressure is turned on.
- Check the plumbing of the solenoids.
- Follow the belt path through the entire conveyor. The belt must be threaded through the drive per the diagram in the Belt Installation section, all of the belts must be captured between the grooved guide pulleys at each diverter location, and no belt should be threaded under a crossmember (belt path labels are attached at each diverter location from the factory).
- Visually inspect the installation. Is the conveyor straight? Is the conveyor reasonably level from side to side? From end-to-end?
- Check guard rail clearance to product.
- Eliminate all catch points.
- Check conveyor elevations.
- All bolts and set screws tight.
- Check product clearance to overhead structures.
- Simulate all operational functions with actual product.
- All guards in place with proper clearance.
- All OSHA required guards in place on walkways, catwalks, ladder-ways, floor openings, etc.
- All labels and warning signs in proper place, unobstructed.

6.23.2 Mechanical Dynamic Checkout

(Power to the conveyor, but no product on it.)

- Turn the motor on. With the belt moving make sure each belt has proper tension.
- Actuate each diverter solenoid manually.
- Check the belt tracking.

 WARNING	
	<p>Hazard to Equipment or Personnel</p> <p>NBS90 Transfer motors must be controlled to run on demand</p>
<p>Indicates a medium level potentially hazardous situation that, if not avoided, could result in death or serious injury.</p>	

6.24 NBS MAINTENANCE & TROUBLESHOOTING

General



The key to ensuring the expected return on investment is to protect against premature failure with a well-planned program of preventive maintenance.

Preventive maintenance programs examine what may fail and then formulate action plans which will prevent failure or downtime. This kind of maintenance includes lubrication and replacement or repair of parts before failure but after expected life has been attained.

Preventive maintenance will save expensive downtime and wasted energy. It will increase the life of components. Along with preventive maintenance, there should be a record-keeping system. You must know what problems you have had in the past and when different components were serviced.

A visual and audible inspection should be taken every day. You can see if a chain is loose, oil leaking, sprocket worn; or you can hear a faulty bearing, noisy chain or any other noise that might indicate a problem. When something major goes wrong with some component, records should be kept to see if a pattern to the problem occurs.

All personnel working in close proximity to the conveyor should inform maintenance or their supervisor of any unusual noise.

 WARNING	
	<p>Hazard to Equipment or Personnel</p> <ul style="list-style-type: none">• Do not perform maintenance on the conveyor until the startup controls are locked out and cannot be turned on by any person other than the one performing the maintenance. If more than one member of a crew is working on the conveyor, EACH CREW MEMBER MUST HAVE A LOCK ON THE POWER LOCK OUT. The air pressure must be turned off to the work area. All pneumatic devices must be de-energized to prevent accidental cycling of the device.• Make sure personnel are clear of all conveyor equipment before restarting the system.
<p>Indicates a medium level potentially hazardous situation that, if not avoided, could result in death or serious injury.</p>	

6.25 GEARMOTOR



The drive unit should be checked monthly. Check the gearmotor for leaking seals. Check the gearcase for proper oil level and add the approved oil for your particular unit. Check for overheating, vibrations, and dirt buildup.

Each Nord gearmotor is supplied from the factory with the correct grade and quantity of lubricant for the specified mounting position. Under special circumstances such as high or low ambient temperatures, optional oils should be used.

6.26 ROLLERS



All rollers used in NBS equipment have precision, sealed lubed for life bearings, and do not require maintenance. Periodically removing the rollers has an added benefit of distributing the wear on the bearing inner race by rotating the axle to a new position. If a defective roller bearing is found, replace the roller.

Do not allow tape, banding, shrink wrap, etc. to build up on roller or pulleys. This can cause rollers to jam and the belt to mistrack. If this is a common occurrence due to the product packaging, clean up on a regular schedule.

 WARNING	
	<p>Hazard to Equipment or Personnel</p> <p>Use a blunt object to remove rollers from frame like a putty knife and a screwdriver. Using sharp pointed object could slip and cause injury.</p>
<p>Indicates a medium level potentially hazardous situation that, if not avoided, could result in death or serious injury.</p>	



6.27 AIR SYSTEM

The best preventive maintenance for any air operated device is clean air. Always be alert for air leaks anywhere in the system and correct promptly. Check all airline filter bowls weekly for accumulated water and drain if necessary. Check for proper PSI settings on air regulators.

 WARNING	
	<p>Hazard to Equipment or Personnel</p> <ul style="list-style-type: none"> • Check to confirm tools and foreign objects have not been left on or inside the conveyor. • Check to confirm all loosened parts have been retightened. • Check to confirm all guards have been installed. • Prohibit riding on conveyor by anyone. • Think before making any adjustments. It may prevent injury. Remember, all moving components are potentially dangerous. • Protect yourself from unexpected starts when working on a stopped unit by locking and tagging the control panel or disconnect switch that supplies power to the unit.
<p>Indicates a medium level potentially hazardous situation that, if not avoided, could result in death or serious injury.</p>	

6.28 MOTOR CONTROLS

Inspection (Semi-Yearly)

 WARNING	
	<p>Hazard to Equipment or Personnel</p> <ul style="list-style-type: none">• Before servicing or performing any work in the motor control panel, disconnect and lockout the main incoming service. If only the panel disconnect is off, the incoming side will still be hot.• Avoid touching components until they have had time to cool. Some may still be hot.
<p>Indicates a medium level potentially hazardous situation that, if not avoided, could result in death or serious injury.</p>	

Excessive overheating is indicated by discoloration of components. Most often, these symptoms are a sign of loose connections. If left uncorrected this can eventually cause arcing between components, leading to destruction of the controls. It is normal to find the interior of the control cabinet very warm when it is first opened.

The condition of contacts must be checked on all contactors and starters that show signs of overheating. Make sure that they are free of dust and are not excessively pitted or burned. When badly burned or worn, the contacts must be replaced.

In the course of inspecting contact condition, spring pressure should be checked. As contact surface wears down, spring pressure can be lost because of the overheating. Contact spring resiliency can usually be detected by fingertip pressure.

Check for faulty door gaskets especially when there are excessive deposits of foreign materials. Particular attention should be given to conductive deposits because they can cause flashovers and premature component failure when allowed to collect to any great extent. Either reposition or replace defective gaskets and clean the control cabinet.

Check all overload settings on motor controls. Check for loose wiring and tighten as required.

Cleaning

When cleaning a control cabinet, it is best to use a vacuum cleaner rather than compressed air. A vacuum cleaner removes rather than redistributes dust and dirt. Compressed air can damage and displace relay contacts and springs.

6.29 NBS MAINTENANCE CHECKLIST

End Pulley Assembly

- Examine end pulley assembly. Remove any residue clinging to end pulley, and end pulley snubber.
- Check to see if belt is tracked correctly thru lower belt guide wheels. Examine guide wheels for wear. Replace any wheels that are excessively worn.
- Remove any residue or buildup of fibers between UHMW rails at joints.

Intermediate Bed Assembly

- Remove any residue or buildup of fibers between UHMW rails joints.
- Remove any residue or build up on carrier rollers.

Drive Assembly

- Examine drive pulley for excessive lagging wear.
- Remove any residue built up on drive pulley.
- Check to see if belt is tracked correctly thru lower belt guide wheels. Examine guide wheels for wear. Replace any wheels that are excessively worn.
- Examine the belt guide feeder rollers. Remove any residue built up on rollers.
- Examine individual take up wheels for wear. Clean off any build up on wheels.
- Examine take-up snubber pulleys. Clean off any residue built up on pulleys.
- Check chain tension. An over tensioned chain will cause excessive gearbox noise

Transfer Module

- Remove any residue or build up on transfer rollers.
- Check tension of both timing belts. (Drive and jump belts)
- Check height of transfer rollers above the belt top surface. Check the plane passing over the transfer rollers for level and parallelism to belt surfaces. Replace any missing hardware and tighten any loose hardware.

Encoder

- Remove any residue or buildup on encoder wheels.

6.30 MAINTENANCE SCHEDULE



Periodic maintenance intervals shown may vary with load, speed, hours of daily operation, ambient temperature, humidity, etc. Intervals can be established by fairly frequent maintenance at first, then lengthen the intervals as justified by observation of need based on history. The following is based on 5 days per week, 8 hours per day under normal conditions.

Daily

- Listen to everything for unusual noises or vibration.
- Visually inspect to see that conveyor sections are clear and free of debris.
- Check to see that all safety guards are in place.
- Check any oil leakage.
- Check any unusual noises or vibration.
- Check for loose bolts or parts.
- Check air filter bowls for accumulated water.
- Listen for air leaks.

Weekly

- Inspect bearings, gear reducers and motors for excessive noise or heat.
- Clean breather cap on gear motor (if used).
- Check operation of all electrical controls.
- Inspect motor mounting bolts.
- Check for proper PSI on air regulators.

 WARNING	
	<p>Hazard to Equipment or Personnel</p> <ul style="list-style-type: none">• Prohibit riding on conveyor by anyone.• Think before making any adjustments. It may prevent an injury. Remember, all moving components are potentially dangerous.• Protect yourself from unexpected starts when working on a stopped unit by locking and tagging the control panel or disconnect switch that supplies power to the unit.
<p>Indicates a medium level potentially hazardous situation that, if not avoided, could result in death or serious injury.</p>	

Monthly



- Check air filters for cleanliness.
- Clean chains and sprockets and lubricate with SAE 30 weight oil or equivalent. (Check chain tension and tightness of all adjusting screws.)
- Check drive unit for leaking seals and oil level in gearcase (if applicable), unusual noises, vibration, and stress cracks.

Semi-Yearly

- If dry sounding, lubricate unsealed bearings in rollers with light oil. Check free spin of rollers.
- Drain and flush gearcase after each 2,500 hours of normal operation or at least every 6 months (if applicable).
- Grease motor shaft bearings.
- Inspect and clean motor control centers.
- Grease regreasable bearings.

Yearly



- Change oil in gearboxes.
- Inspect tightness of all nuts and bolts on units, adjust if necessary and tighten.
- Check for plumb and level. Shims have been known to vibrate out from under supports in isolated incidents.
- Touch up paint that has been chipped. Unpainted surfaces will rust.
- Inspect for stress/fatigue cracks in frame and supports.
- Inspect DC motor brushes for wear and replace if necessary or after every 5,000 hours of normal operation.

 WARNING	
	<p>Hazard to Equipment or Personnel</p> <ul style="list-style-type: none"> • Check to confirm tools and foreign objects have not been left on or inside the conveyor. • Check to confirm all loosened parts have been tightened. • Check to confirm all guards have been installed.
<p>Indicates a medium level potentially hazardous situation that, if not avoided, could result in death or serious injury.</p>	

6.31 NBS TROUBLESHOOTING GUIDE

	Problem	Possible Cause	Remedy
1.	Belts rolling out of guide tracks	Conveyor not installed straight	Straighten conveyor
		Conveyor not installed level	Inspect conveyor to insure there are not low/high spots at the divert points. Re-level conveyor as necessary
		Air pressure for the belt take-up is set too low	Set air pressure to the proper PSI. Reference IOM manual
		Divert is not rising to proper height	Verify air pressure setting.
		Divert is not rising to proper height	Verify the number of diverts per air drop. Consult IOM Manual to verify that number of diverts per air drop does not exceed MHS recommendations.
		Divert spur is not set to the proper height	Inspect and adjust height of divert spur as needed.
2.	Divert Tub engaging at wrong time	PLC programming	Inspect timing of logic with encoder to ensure data is correct.
		Solenoid wired incorrectly	Inspect wiring and adjust accordingly.
		Clogged solenoid	Inspect solenoid valve to ensure no water is present
3.	Belt Failure	Routing of belt	Inspect belt routing to ensure proper installation. Refer to IOM Manual for additional information.
		Belting rails not aligned properly	Check rail alignment at joints to ensure proper alignment.
		Incorrect belt tension	Inspect air pressure within belt take-up to ensure proper setting
4.	Product not diverting correctly	Discharge conveyor unit not in proper location	Based upon product being handled on the NBS discharge conveyor location is variable; refer to IOM Manual for further assistance.
		Height of discharge conveyor is not correct	Inspect discharge conveyor and adjust accordingly.
5.	Loud humming noise	Belts installed incorrectly	Inspect belt installing to ensure proper side is making contact with the rail.

7 NBS REPAIR OR REPLACE PROCEDURES

 WARNING	
	<p>Hazard to Equipment or Personnel</p> <p>Before removing a valve or other pneumatic component, shut off and exhaust the entire pneumatic circuit and shut off and lock out electrical supply.</p>
<p>Indicates a medium level potentially hazardous situation that, if not avoided, could result in death or serious injury.</p>	

7.1 GEARMOTORS

NBS drive units use Gearmotors which are properly filled at the factory with sufficient lubrication for more details contact the specified gearmotor manufacture details.

Disassembly/assembly procedure as follows:

- Remove necessary guards to access maintenance areas.
- Disconnect any electrical connection.
- Remove Gearmotor.
- Perform required maintenance.
- Reverse procedures for assembly.
- After all fasteners are tight, double check chain tension and sprocket alignment.
- Replace all guards.

7.2 SOLENOID VALVES

In order to minimize downtime, it is normally not feasible to repair malfunctioning electrical or valve components while leaving the conveyor unusable. Spare components should be kept in stock for emergency replacement. If feasible, the part may be repaired later to replace maintenance stock. Items which cannot be readily repaired or are questionable should be replaced. Components under warranty should not be repaired except in an emergency.

7.3 NBS 90 POLYSORT TRANSFER REPLACE THE HABASIT BELT

Step 1: Turn off the power supply.

Step 2: Turn off the air supply.

Step 3: Loosen the rail hardware located on the bottom of the rails.

Step 4: Loosen the rail hold down clamps and turn to unclamp the rails.

Step 5: Remove the rails.

Step 6: Move the belts to the sides.

Step 7: Remove the access panel on the side of the transfer unit.

Step 8: Remove the top half of the end cover on the transfer unit.

Step 9: Loosen the two outermost sheaves on each side to release the tension of the belt.

Step 10: Remove the rollers.

Step 11: Remove the three center sheaves located above the motor pulley.

Step 12: Loosen the motor pulley. Slide the old belt behind the pulley to remove.

Step 13: Loosen the motor bolts.

Step 14: Install the new belt. Make sure the green part of the belt faces the motor pulley.

Step 15: Tighten the motor pulley.

Step 16: Reinstall the three center sheaves. Make sure to assemble the sheave with the short spacer on the bolt first and then push the bolt through the sheave on the C-clip side then slide the long spacer over the end of the bolt.

Step 17: Thread the belt as shown.

Step 18: Move the belts back in place and tighten the motor bolts.

Step 19: Tighten the two outermost sheaves on each side.

Step 20: Reinstall the rollers and make sure the belt loops above each roller.

Step 21: Use a Sonic Tension Tester to measure the tension of the Habasit belt.

Enter in the belt tension factors:

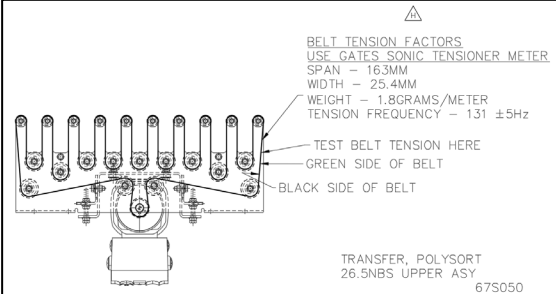
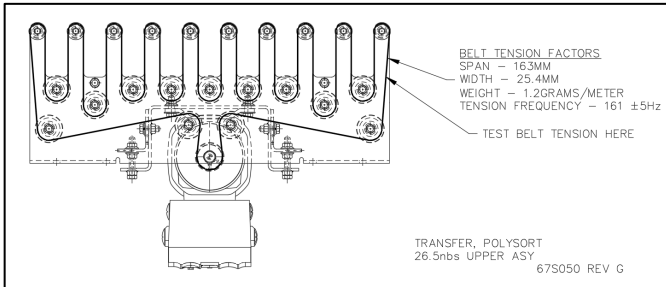
Current Habasit Belt Number 1235094 (Green & Black)	Obsolete Habasit Belt Number 1220933 (Green & Yellow)
<p>Sonic Tension Tester Factors</p> <ul style="list-style-type: none"> • Span 163 mm • Width 25.4 mm • Weight 1.8 grams/meter <p>Tension Frequency Range = 131 ± 5 Hz</p> 	<p>Sonic Tension Tester Factors</p> <ul style="list-style-type: none"> • Span 163 mm • Width 25.4 mm • Weight 1.2 grams/meter <p>Tension Frequency Range = 161 ± 5 Hz</p> 

Step 21.1: Hold the microphone approximately 1 inch by the belt. Using your finger, flick the belt so it makes a vibration. The sonic tester will measure the vibration and give you a reading. Test the belt at least 3 times to get an average reading.
Tension Frequency Range should be 131 ± 5 HZ.

Step 21.2: If the Tension Frequency Range is wrong, loosen the four clamping bolts and adjust the four take-up hex screws. Repeat tension process. When the test is correct, tighten all the take-up lock nuts and the clamping bolts.

Step 22: Install the rails and tighten the hardware under the rails.

Step 23: Turn the hold down clamps to lock in the rails and tighten.

Step 24: Reinstall the access panel and end cover on the transfer unit.

Step 25: Turn on the air and power.

Maintenance Video is available at: <https://mhs-conveyor.com>

8 PARTS IDENTIFICATION

8.1 REPLACEMENT PARTS IDENTIFICATION

This section is used to identify parts that may require replacement during the life of the conveyor. Parts which specifically pertain to MHS Conveyor are included with illustrations.

A "Recommended Spare Parts List" is published for all conveyor orders of \$20,000 or more. This spare parts list is sent to the purchaser approximately (2) weeks after the order is received. It includes part numbers, description, pricing, and recommended quantities to be kept on hand for maintenance.

If you are unable to locate this document, another may be obtained by contacting the MHS Lifetime Services at 231-798-4547.

8.2 SPARE PARTS PRIORITY LEVEL EXPLANATIONS

Level #1

Failure of a priority level #1 spare part ("A" level part) may cause major disruption of system performance.

Priority level 1 spare parts must be on-hand, and available to be replaced in the event of a component failure that could shut down a critical function of a conveyor system.

Priority level 1 spare parts include motors, gear reducers, gearmotor, motorized rollers, air solenoid valves, and related components. The majorities of these parts are purchased from MHS Conveyor vendors and carry their own warranties through these vendors. For more warranty information, see MHS Conveyor Equipment Warranty.

Level #2

Failure of a priority level #2 spare parts ("B" level part) usually is gradual and should not cause a major system disruption.

Priority level 2 spare parts are parts required for smooth system operation and preventative or regular mechanical maintenance.

Priority level 2 spare parts include roller chain, sprockets, belt pulleys, rollers, air cylinders, and other related parts whose failure should not stop a conveyor system suddenly. These parts tend to wear out gradually and are not known to fail suddenly.

Level #3

Priority level #3 parts ("C" level part) rarely fails and are easily obtainable.

Priority level 3 spare parts are parts that rarely fail or maybe optionally used by the customer.

8.3 NBS90 POLYSORT INTERMEDIATE BED AR W/AIR TAKE-UP 4'0"

ASSEMBLY NOTES:

1. RAIL ALIGNMENT IS CRITICAL FOR PROPER CONVEYOR PERFORMANCE.
2. SET UHMW FLUSH TO END OF ALUMINUM EXTRUSION, CLAMP END DOWN AND DRIVE SELF DRILLING SCREWS IN FLUSH FROM BOTTOM SIDE OF EXTRUSION, TO HOLD UHMW FROM SLIDING DOWN TO END OF CONVEYOR.

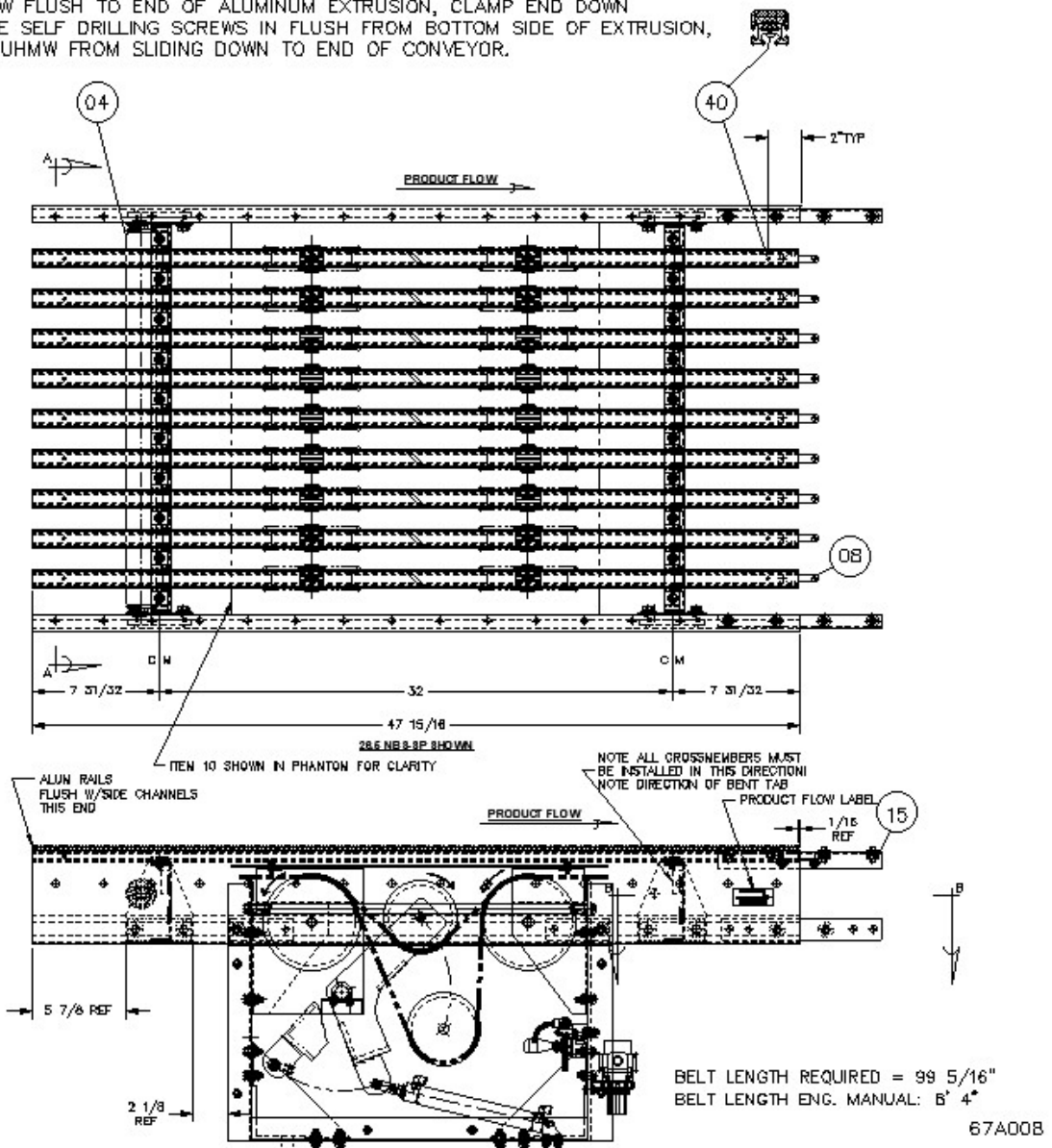



8.3.1 Replacement Parts – NBS90 PolySort Intermediate Bed AR W/Air Take-up 4’0”

NBS90 POLYSORT BELT TAKE-UP		
BED, NBS SP-26.5W-TAKEUP-AR-4'0"-AIR OP		26.5W
Balloon	Description	Item #
04	ROLLER, RET 26.5NBS-SP 1.9PRBG	1202217
BELT TAKE-UP SUB ASY 26.5NBS-SP		----
01	WHEEL, IDLER PULLEY 5.5" DIA	1214526
02	WHEEL, IDLER PULLEY 4" DIA	1214527
18	CYL, AIR BIMBA 096.75-DP-1-1/16"BORE X 6.75"ST	1220678
26	TUBING,3/8"POLYU-95DURO 1/4"ID	E0001392
27	TUBING,1/4"POLYU-95DURO.160ID	E0001391
50	VALVE, CLIPPARD MMV-L4QD 4 WAY	1115797
51	REGULATOR, SMC	1133882
		REF DWG# 67A008

8.4 NBS90 POLYSORT STANDARD END DRIVE AR

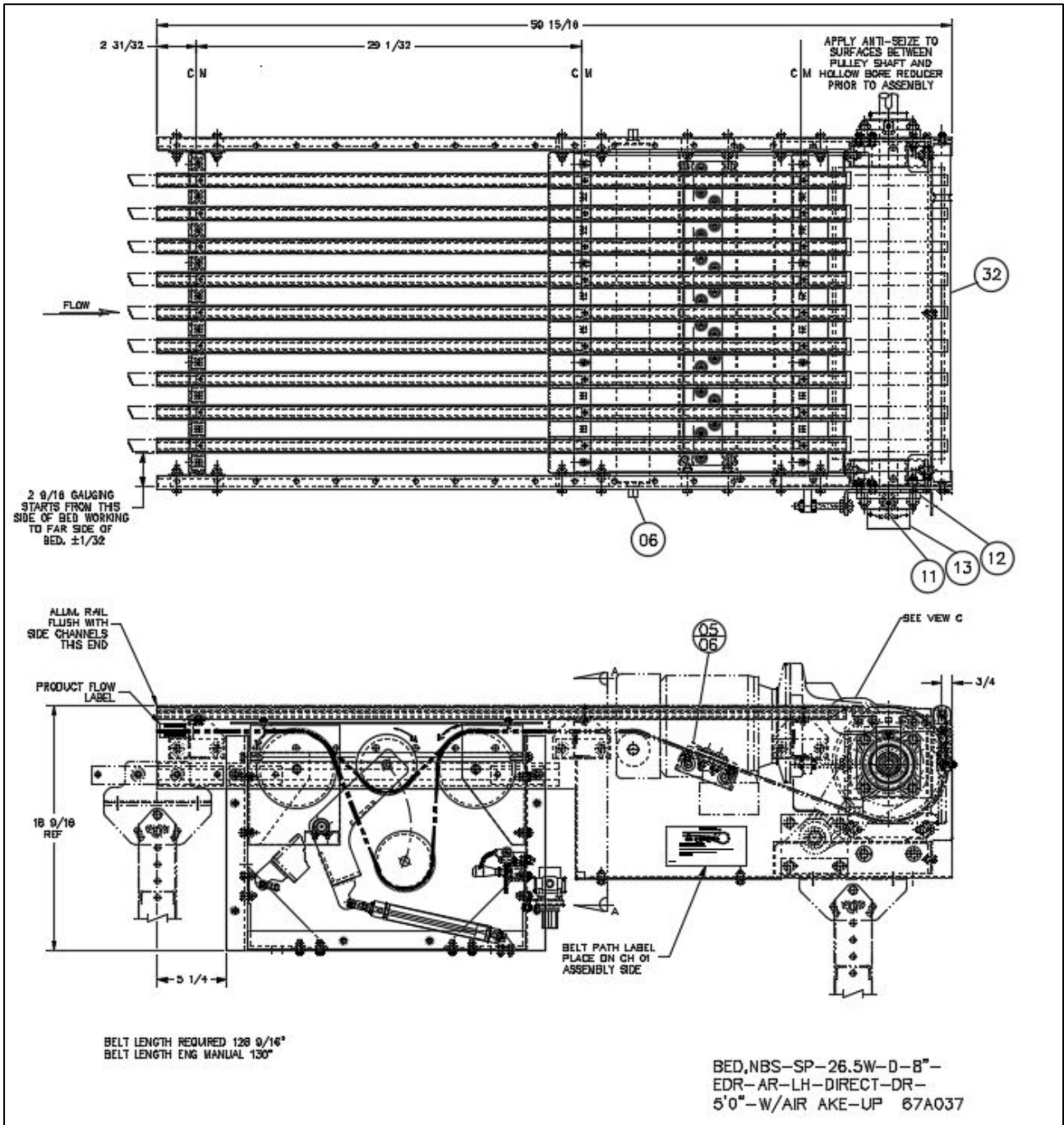



8.4.1 Replacement Parts – NBS PolySort Standard End Drive-AR

DRIVE BED, NBS90 POLYSORT STANDARD END DRIVE		
BED, NBS SP-26.5W-D-8"-EDR-AR, LH-5'0"-DIRECT-W/AIR TAKEUP		26.5W
Balloon	Description	Item #
05/06	BRG, R6 ZZ C3	90050111
06	PULLEY, 26.5NBS-SP 2.5 DIA	1212889
11	PULLEY, 8"DIA DR 26.5NBS-SP	1205794
12	BRG, FLG 4BOLT X 1-7/16"	1114091
13	COVER, BRG END EC-207-Y, SNAP ON STYLE	1114092
32	ROLLER, DR GAP 26.5NBS-SP	1202590
BELT TAKE-UP SUB ASY 26.5NBS-SP		----
01	WHEEL, IDLER PULLEY 5.5" DIA	1214526
02	WHEEL, IDLER PULLEY 4" DIA	1214527
18	CYL, AIR BIMBA 096.75-DP-1-1/16"BORE X 6.75"ST	1220678
26	TUBING, 3/8"POLYU-95DURO 1/4"ID	E0001392
27	TUBING, 1/4"POLYU-95DURO.160ID	E0001391
50	VALVE, CLIPPARD MMV-L4QD 4 WAY	1115797
51	REGULATOR, SMC	1133882
REF DWG# 67A037		

8.5 NBS90 POLYSORT BELT TAKE-UP

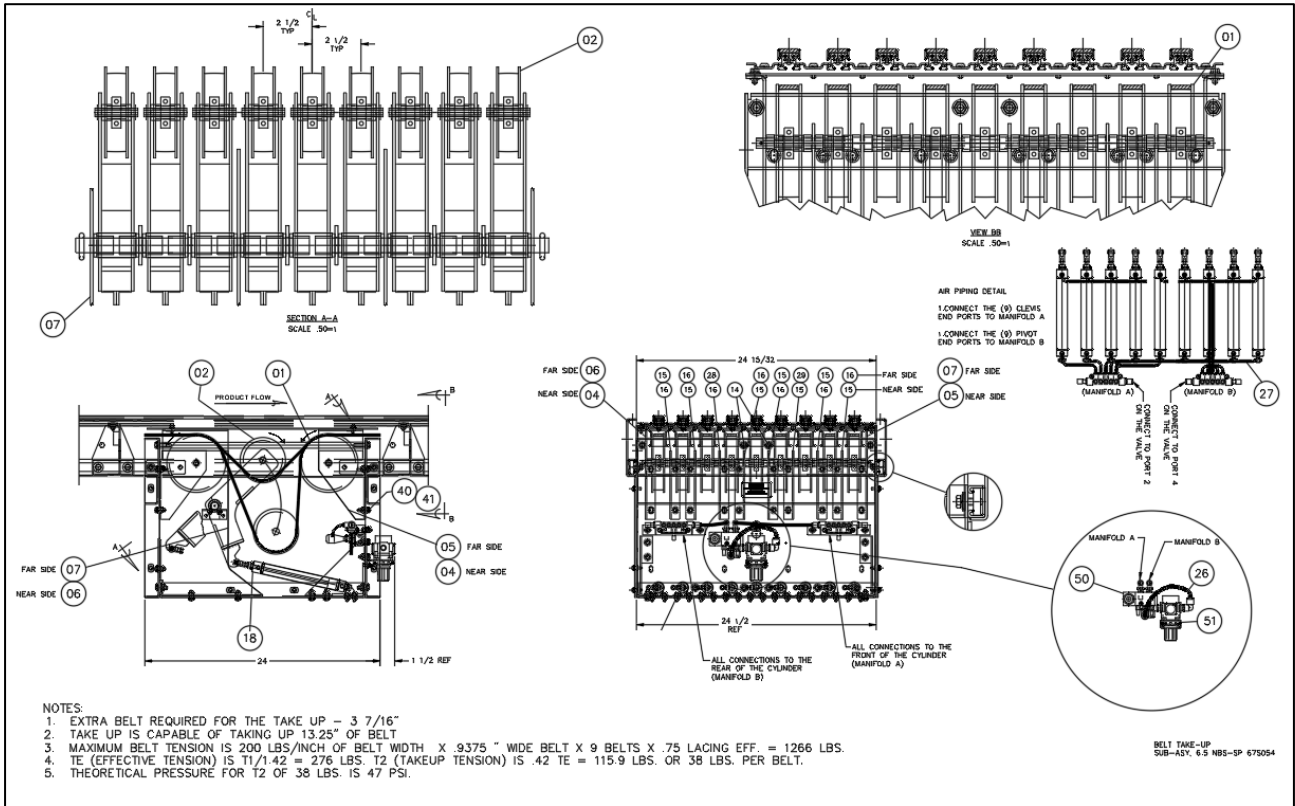

8.5.1 Replacement Parts – NBS90 PolySort Belt Take-up

TAKE-UP, 26.5 POLYSORT ASSEMBLY		
Balloon	Description	Item #
01	WHEEL, IDLER PULLEY 5.5" DIA	1214526
02	WHEEL, IDLER PULLEY 4" DIA	1214527
18	CYL, AIR BIMBA 096.75-DP-1-1/16"BORE X 6.75"ST	1220678
26	TUBING, 3/8"POLYU-95DURO 1/4"ID	E0001392
27	TUBING, 1/4"POLYU-95DURO.160ID	E0001391
50	VALVE, CLIPPARD MMV-L4QD 4 WAY	1115797
51	REGULATOR, SMC	1133882
Ref Dwg# 67S054		

8.6 NBS90 POLYSORT TRANSFER ASSEMBLY

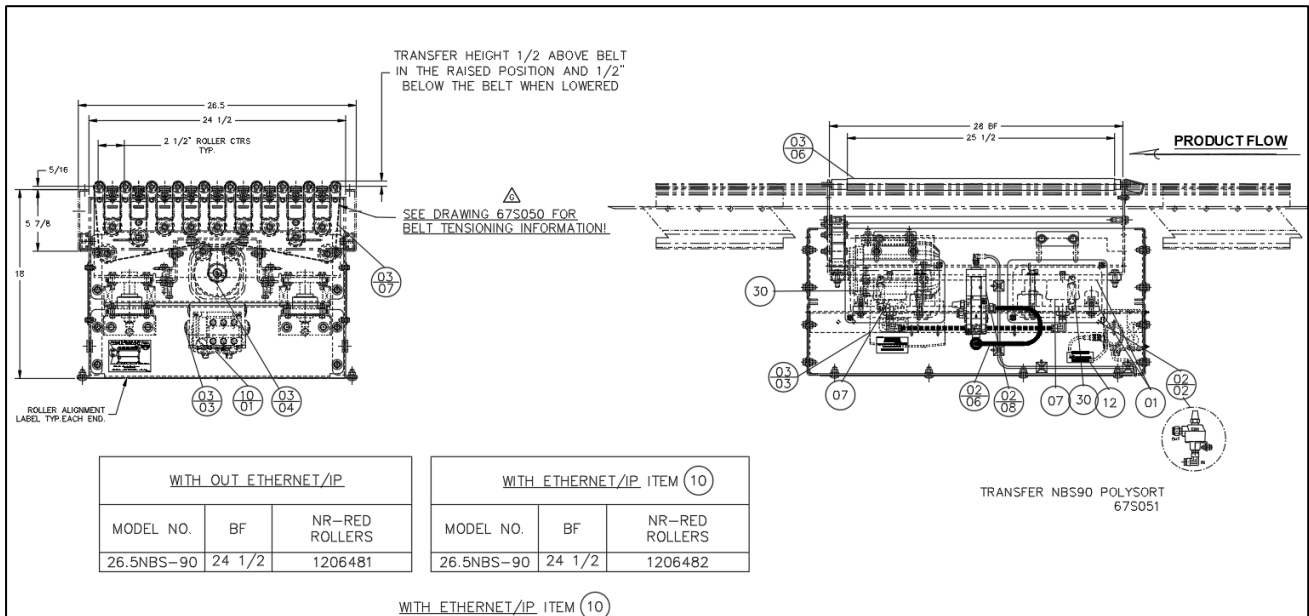

8.6.1 Replacement Parts - NBS90 PolySort Transfer Assembly

NBS90 POLYSORT TRANSFER		
TRANS, NBS-90D-26.5-POLYSORT-__VDC WITH OR WITHOUT ETHERNET		26.5W
Balloon	Description	Item #
01	LIFTTABLE, NBS-90 POLYSORT	1206338
07	AIRBAG, FIRESTONE #W02-358-3000	90000025
30	SPRING, EXT 3/4OD X 2"LG .072W	1213570
02/02	VALVE, QUICK EXHAUST #QE3	89000034
02/06	TUBING, 3/8"POLYU-95DURO 1/4"ID	E0001392
02/08	VALVE, SMC 3WAY 24VDC 2.2CV, W/FITTINGS NBS-SP90 POLYSORT	1206332
03/03	MTR, EURO MOVIMOT 0.75HP 460V, PRESET F1=4.5T1=0 DIPS SET OFF	1203208
03/04	SHEAVE, DRIVE NBS-SP POLY SORT, 304SS	1206407
03/06	ROLLER, NBS-SP90-25.5 28BF-W/POLYURETHANE SLEEVE 60-65DUR	1234878
03/07	BELT, HABASIT 1"WIDE X 151-5/8"- TF-10 ENDLESS	1235094
10/01	MOD, MOVIMOT, ETHERNET/IP, W/ MFZ21D CONNECTOR BOX	1204731
		REF DWG# 67S051

8.7 NBS90 POLYSORT END PULLEY AR 1'6"

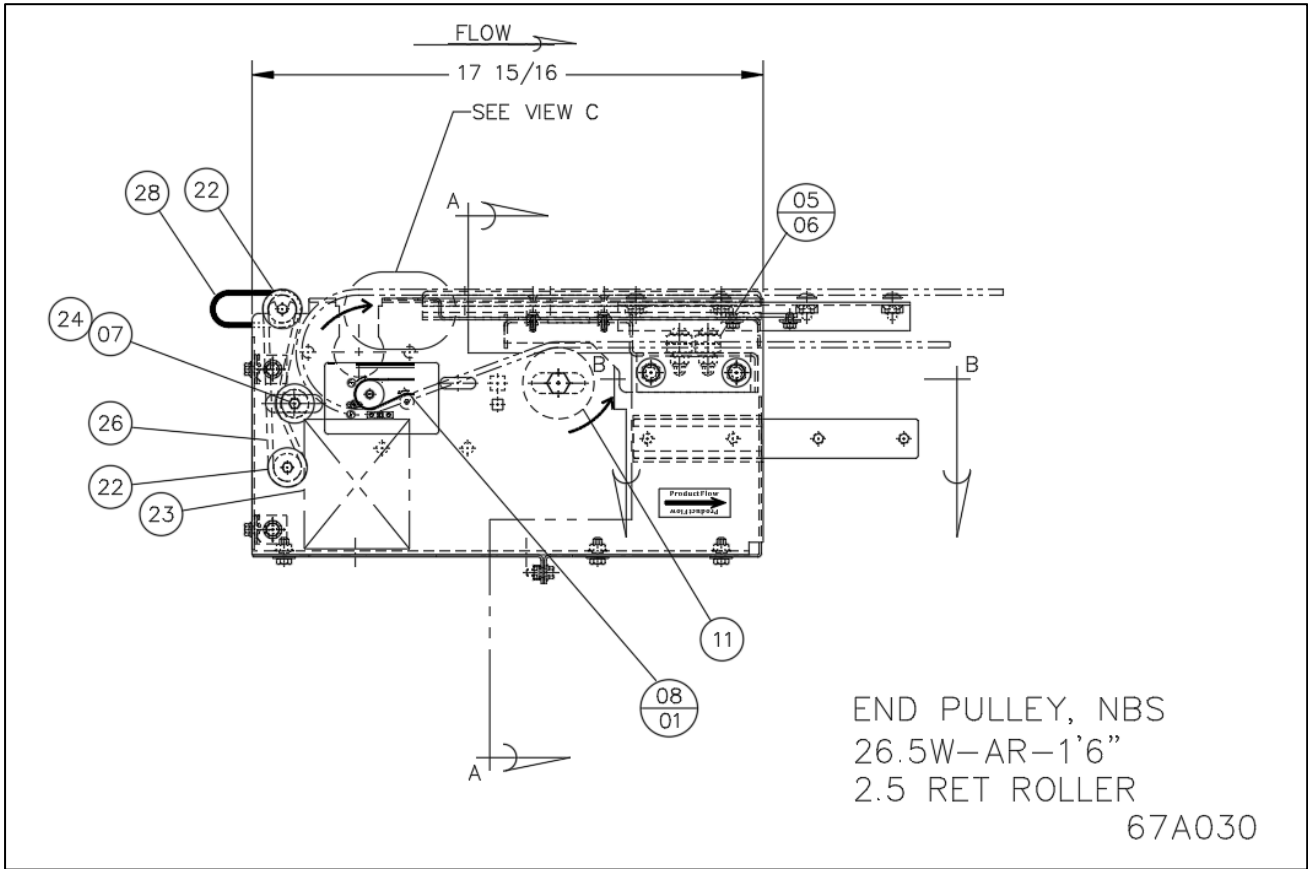

8.7.1 Replacement Parts - NBS90 PolySort End Pulley AR 1'6"

NBS POLYSORT END PULLEY ALUMINUM RAIL (AR) 1'6"		
END PULLEY, NBS-SP 26.5W AR 1'6"		26.5W
Balloon	Description	Item #
05/06	BRG, R6 ZZ C3	90050111
07	ROLLER, SLIDE 11/32HEX NBS-SP	E0002716
08/01	PULLEY, 4"DIA 26.5 NBS-SP	1204198
11	PULLEY, 26.5 NBS-SP 2.5 DIA	1212889
22	ROLLER, SLV 26.5 NBS-SP E-PULL	1202529
23	PHOTOEYE, RETO RAY10- CONN TYPE PIGTAIL	1214548
24	ROLLER, IDLER 26.5 NBS-SP 4"END	1202530
26	ORING, 83A 3/16 X 12-1/2"	90530019
28	ORING, 83A 5/32 X6-1/4"ST TRANS	E0001299
		Ref Dwg# 67A030

8.8 NBS90 POLYSORT 4' END PULLEY BED WITH AIR TAKE-UP

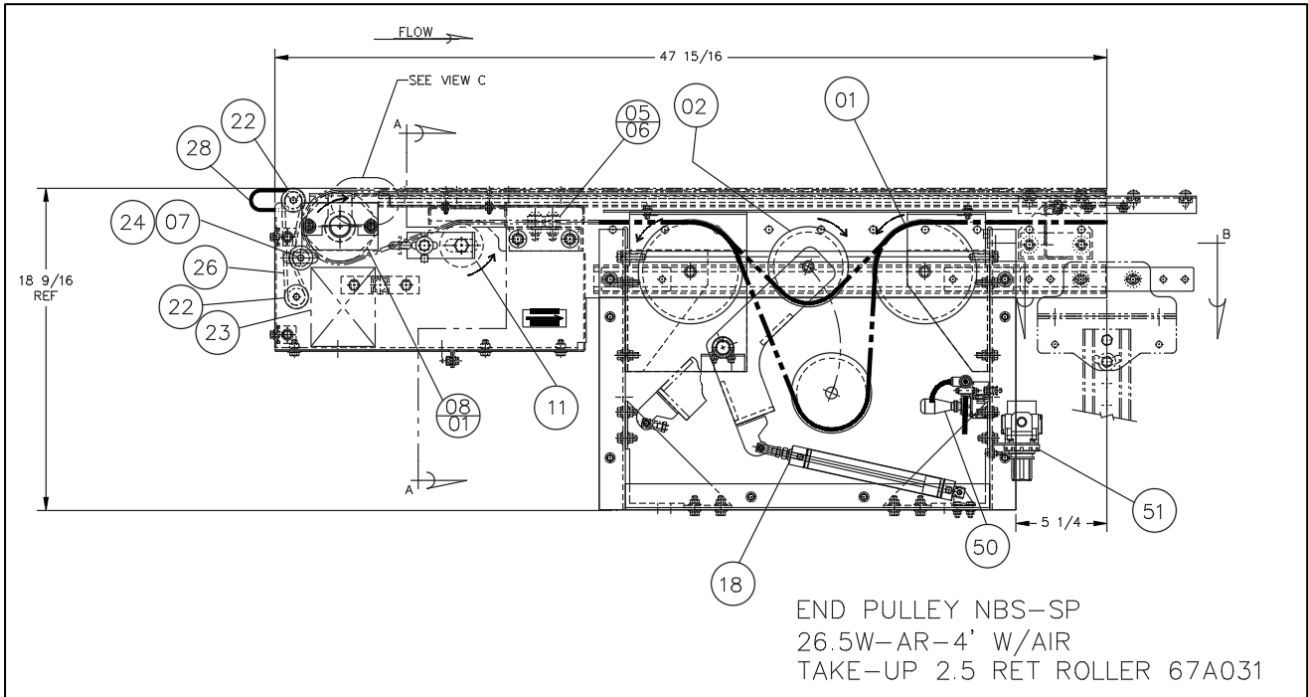

8.8.1 Replacement Parts – NBS90 PolySort 4' End Pulley bed with Air Take-up

NBS POLYSORT NBS90 POLYSORT 4' END PULLEY BED WITH AIR TAKE-UP		
END PULLEY, NBS-SP 26.5W AR 4'		26.5W
Balloon	Description	Item #
05/06	BRG, R6 ZZ C3	90050111
07	ROLLER, SLIDE 11/32HEX NBS-SP	E0002716
08/01	PULLEY, 4"DIA 26.5 NBS-SP	1204198
11	PULLEY, 26.5 NBS-SP 2.5 DIA	1212889
22	ROLLER, SLV 26.5 NBS-SP E-PULL	1202529
23	PHOTOEYE, RETO RAY10- CONN TYPE PIGTAIL	1214548
24	ROLLER, IDLER 26.5 NBS-SP 4"END	1202530
26	ORING, 83A 3/16 X 12-1/2"	90530019
28	ORING, 83A 5/32 X6-1/4"ST TRANS	E0001299
BELT TAKE-UP SUB ASY 26.5NBS-SP		
01	WHEEL, IDLER PULLEY 5.5" DIA	1214526
02	WHEEL, IDLER PULLEY 4" DIA	1214527
18	CYL, AIR BIMBA 096.75-DP-1-1/16"BORE X 6.75"ST	1220678
25/26	TUBING, 3/8"POLYU-95DURO 1/4"ID	E0001392
25/27	TUBING, 1/4"POLYU-95DURO.160ID	E0001391
50	VALVE, CLIPPARD MMV-L4QD 4 WAY	1115797
51	REGULATOR, SMC	1133882
		Ref Dwg# 67A031

8.9 NBS90 POLYSORT ENCODER ASSEMBLY

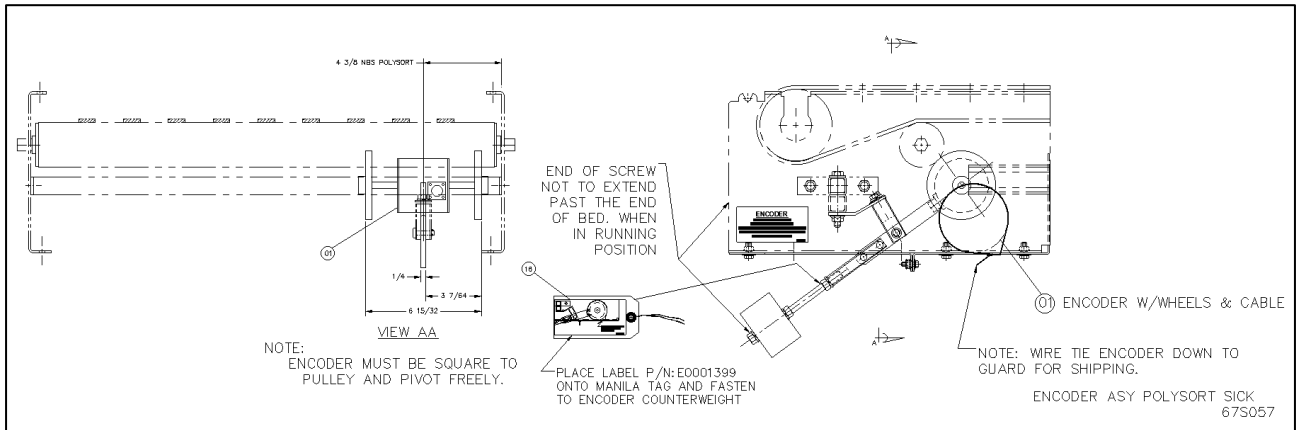

8.9.1 Replacement Parts – NBS90 PolySort Encoder Assembly

NBS-POLYSORT ENCODER WITH CABLE & CONNECTORS		
ENCODER, NBS POLYSORT		
Balloon	Description	Item #
01	ENCODER, NBS SP-SICK	1220461
REF DWG# 67S057		



9 NBS90 POLYSORT REVISION HISTORY

Revision Date	Chapter and Description	Initials
6/22/2021	Update Encoder part numbers per ECN 11836	SJ
7/30/2021	Updated End Pulley [1214086] 67A031 and End Drive [1217417] 67A037 to show changes in take-up. Revised PN 1213259 to 1220678 per ECN 11844	MM
07/30/2021	Roller changed 1206310 to 1215752 per ECN 11852	DG
8/19/2021	Belt number changed from 1202961 to 1220933 ECN# 11901	DG
9/14/2021	Filter part number changed from E0005776 to 1221064 updated the drawings & part number	DG
9/14/2021	Encoder drawings updated	ST
9/14/2021	Updated Logo and format	MD AB
10/19/2021	Updated temperature specification	MD
01/04/2021	Roller change (Phantom Sub Assembly) from 1215752 to 1221431 per ECN 12014 no revision change	DG
3/17/2022	Removed programmable wheeled encoder RH-P144AJ and updated NBS90-SP Encoder parts drawing 67S037	ST
4/21/2022	Replaced roller 1221431 with 1162464 per ECN 12090	DG
5/13/2022	Update air take-up from 80-85 to 45-50 per ECN 12106	DG
9/6/2023	Add yearly inspection section - DC motor brushes	CN
10/25/2023	Discontinued NBS90-SP - Removed from manual	SM, DG, MD
10/09/2024	Add a new Habasit belt 1235094 and remove the old belt 1220933.	DG
10/09/24	Add Maintenance instruction to replace the transfer Habasit belt	DG, MD
10/09/2024	Updated Format and safety information	MD
10/13/2024	Update Roller part number 1162464 to 1234878 and Spare parts to include 4' End Pulley bed w/take-up	AE, CN

MHS GENERAL INFORMATION

For additional manuals, videos, and other resources visit our website at:

www.mhs-conveyor.com

ABOUT MHS CONVEYOR

About MHS Conveyor

MHS Conveyor, located in Norton Shores, Michigan, is a leading deliverer of “smart” material handling systems, technologies, products, and services, creating solutions for material flow applications. As a global supplier of conveyor systems and equipment since 1964, MHS Conveyor provides sorters, conveyors, and accessories to satisfy a broad spectrum of accumulation, transportation, and sortation applications.



MHS Conveyor Corp.
1300 E. Mount Garfield Road
Norton Shores MI 49441-6097 USA
231.798.4547
Email : usinfo@mhs-conveyor.com
Web Site : mhs-conveyor.com



Regional sales offices and authorized Business Partners located throughout the United States and Canada. Licensees and Business Partners in Europe, South America, and Southeast Asia.