

Installation, Operation, and Maintenance Manual

CRUZcontrol®

GENERATION 2 FOR NBC™

Revision Date: June 01, 2025

Document Part Number: 1118211

FORTNA • 131 Griffin Way • Mt. Washington, KY 40047

©2002 - 2026

FORTNA

DOCUMENT VERSION HISTORY

Revision Date	Chapter and Description	Initials
9/27/2021	Update name to FORTNA Conveyor, logo, and format	MD AB
4/20/2023	Revised power supply part number description and pictures. Added power assembly drawing 165S278.	DG, MD
1/1/2026	Update logo, format, safety, and added Preface information.	AB, MD

PREFACE

1.1 DISCLAIMER

It is the Customer's and the system user's responsibility to ensure that the system is operated only in safe conditions and in accordance with this document and any other documentation or instructions provided by FORTNA Inc. or its representatives. THIS DOCUMENT CONTAINS IMPORTANT WARNINGS AND SAFETY REQUIREMENTS. This document must be available to and accessible by any users or anyone with access to the system so that it may be regularly consulted.

ANY PERSON TO USE OR ACCESS THE SYSTEM IN ANY WAY MUST CAREFULLY READ AND UNDERSTAND THIS DOCUMENT. VISITORS OF ANY KIND, AUTHORIZED AND UNAUTHORIZED GUESTS, CHILDREN, ANIMALS AND ANY OTHER PERSON WHO HAS NOT FULLY READ AND UNDERSTOOD THIS DOCUMENT MUST BE KEPT AT A SUITABLE AND SAFE DISTANCE FROM THE SYSTEM. PHYSICAL CONTACT WITH THE SYSTEM MUST BE AVOIDED AT ALL TIMES. SUITABLE WORK CLOTHING AND PROTECTIVE GEAR ARE REQUIRED.

All FORTNA Inc. warranties will be voided by any misuse of the system, failure to exercise care, in appropriate behavior, failure to comply with this document or other documentation or instructions supplied by FORTNA Inc. or its representatives, or unauthorized modification of the system. Please refer to the applicable FORTNA Inc. warranty document for other warranty limitations.

You must contact FORTNA at usinfo@FORTNA-conveyor.com or (231) 798-4547 immediately with any questions or concerns about this document or the system.

1.2 COPYRIGHT INFORMATION

The information contained in this document is the sole property of FORTNA.

FORTNA reserves the right to make changes to any product or specifications described herein without notice. Copyright law applies to this document. ©2024 FORTNA

The Customer may make copies of this material as deemed necessary for the purpose of training the Customer's employees in the use and operation of the system.

Nothing in this document may be duplicated, distributed, translated, passed on, used, stored in electronic data processing systems, converted to a human or machine language, or stored in electronic data processing systems, in any form or in any other way, either electronically, mechanically, magnetically, manually or in any other manner, or disclosed to third parties without obtaining the explicit written permission of FORTNA. This also applies to images, drawings, and specifications, which are the property of FORTNA.

1.3 TRADEMARKS AND REGISTERED TRADEMARKS

Trademarks or trade names may be used in the document to refer to certain products and/or the source of such products. FORTNA disclaims any proprietary interest in the trademarks and/or trade names used in this document, other than trademarks and/or trade names owned by and/or registered by FORTNA.

1.4 LIMITATION OF LIABILITY

TO THE MAXIMUM EXTENT PERMITTED BY APPLICABLE LAW, FORTNA SHALL NOT BE LIABLE FOR ANY DAMAGES SUFFERED BECAUSE OF USING, MODIFYING, CONTRIBUTING, COPYING, DISTRIBUTING, OR DOWNLOADING THE MATERIALS IN THIS MANUAL.

IN NO EVENT SHALL FORTNA BE LIABLE FOR ANY INDIRECT, EXTRAORDINARY, EXEMPLARY, PUNITIVE, SPECIAL, INCIDENTAL, OR CONSEQUENTIAL DAMAGES (INCLUDING LOSS OF PRODUCTION, REVENUE, PROFITS, USE OR OTHER ECONOMIC ADVANTAGE) HOWEVER ARISING, WHETHER BY BREACH OR IN TORT (INCLUDING NEGLIGENCE), EVEN IF FORTNA HAS BEEN PREVIOUSLY ADVISED OF THE POSSIBILITY OF SUCH DAMAGE. IN NO EVENT SHALL FORTNA BE LIABLE FOR ANY DAMAGES CAUSED BY MISUSE OF THE SYSTEM, FAILURE TO EXERCISE CARE, INAPPROPRIATE BEHAVIOR, FAILURE TO COMPLY WITH THIS DOCUMENT OR OTHER DOCUMENTATION OR INSTRUCTIONS SUPPLIED BY FORTNA OR ITS REPRESENTATIVES, OR UNAUTHORIZED MODIFICATION OF THE SYSTEM.

The customer agrees to sole responsibility for adequate protection and backup of data and equipment used in connection with the product and will not make a claim of any nature against FORTNA for inaccurate output, work delays or lost profits resulting from the use of the materials. Customers agree to hold harmless from and covenant not to sue FORTNA or its affiliates, successors, or assigns for any claims related to FORTNA relating to the foregoing.

1.5 LINKS TO THIRD-PARTY SITES

This user manual may contain links to third-party sites, however, FORTNA Inc. is not responsible for and cannot control these other sites. FORTNA Inc. makes no representations whatsoever about any other website accessed through this user manual. If accessing a non-FORTNA Inc. website, even one that may contain an FORTNA Inc. logo, it is independent from FORTNA Inc. and that FORTNA Inc. has no control over the content on that website. In addition, a link to a non-FORTNA Inc. website does not mean FORTNA Inc. endorsed or accepts any responsibility for the content, or the use of such website.

TABLE OF CONTENTS

DOCUMENT VERSION HISTORY	2
PREFACE	3
1.1 DISCLAIMER	3
1.2 COPYRIGHT INFORMATION	3
1.3 TRADEMARKS AND REGISTERED TRADEMARKS	3
1.4 LIMITATION OF LIABILITY	4
1.5 LINKS TO THIRD-PARTY SITES	4
TABLE OF CONTENTS	5
1.6 TABLE OF FIGURES	7
1.7 TABLE OF TABLES	8
1 SAFETY	9
1.1 CONVEYOR CONTROLS SAFETY GUIDELINES	9
1.2 DANGER AND RISK INFORMATION	11
1.3 SAFETY WHILE WORKING WITH THIS PRODUCT	12
1.4 SYMBOLS USED THROUGHOUT THIS MANUAL	18
1.5 OBLIGATIONS	19
1.6 PROHIBITIONS	22
1.7 PROPER LABELS FOR CONVEYOR TYPES	23
2 ABOUT THIS MANUAL	24
2.1 IOM PURPOSE	24
2.2 MANUAL SCOPE	24
2.3 DOCUMENT OVERVIEW	24
2.4 MANUAL STRUCTURE	24
3 POLICIES	25
3.1 CONVEYOR EQUIPMENT WARRANTY	25
3.2 ENVIRONMENT STANDARDS	25
3.3 INDUSTRIAL ENVIRONMENT	25
4 CRUZCONTROL CONCEPT	26
4.1 CRUZCONTROL LOGIC CAUTIONS	27
4.3 ABBREVIATIONS, ACRONYMS, AND TERMS	28
4.5 CRUZCONTROL LOGIC TYPES	29
4.6 BASIC LOGIC	29
4.7 PROGRESSIVE LOGIC	30
4.8 CRUZCONTROL COMPONENTS	31
4.9 LOGIC ASSEMBLY TYPES	32

- 4.10 FUNCTION MODULES33
- 4.11 TERMINAL AND JUMPER DESCRIPTIONS37
- 4.12 USE OF 115VAC CONTROLS39
- 5 POWER SUPPLIES.....45
 - 5.1 POWER SUPPLY WIRING.....46
 - 5.2 ONE POWER SUPPLY USED TO POWER TWO SEPARATE CRUZCONTROL SECTIONS47
 - 5.3 USING TWO POWER SUPPLIES TO POWER ONE EXTENDED CRUZCONTROL SECTION49
 - 5.4 CRUZCONTROL TECHNICAL DATA51
 - 5.5 ACCESSORIES.....52
- 6 CRUZCONTROL ON SITE INSTALLATION56
 - 6.1 PRE-INSTALLED ON THE CONVEYOR.....56
 - 6.2 FIELD INSTALLATION56
 - 6.3 CONVEYOR FLOW58
 - 6.4 EXAMPLE 8: PRODUCT GAPPING69
 - 6.5 OPERATION.....71
 - 6.6 FUNCTION MODULE TECHNICAL DATA80
- WORKS CITED82
- GENERAL INFORMATION83

1.6 TABLE OF FIGURES

Figure 1: Basic Concept Layout.....	26
Figure 2: Logic Assembly Mode & Alignment.....	31
Figure 3: Function Modules.....	40
Figure 4: Full Function Module Board Layout.....	41
Figure 5: Full Function Module Circuit.....	41
Figure 6: Release Function Board Layout.....	42
Figure 7: Release Function Module Circuit	43
Figure 8: Two Logic Assemblies using a T Cable.....	46
Figure 9: Two Separate CRUZcontrol Sections.....	47
Figure 10: One CRUZcontrol Section with Two Power Supplies	49
Figure 11: Discharge Logic Control.....	53
Figure 12: Logic Assembly.....	57
Figure 13: Left Hand Flow.....	58
Figure 14: Right Hand Flow	58
Figure 15: Isolated Input Single Release.....	61
Figure 16: Non-Isolated Input Single Release.....	62
Figure 17: CRUZcontrol around a curve (low rate).....	64
Figure 18: CRUZcontrol around a curve. (High rate).....	66
Figure 19: Function Module Wiring	66
Figure 20: Work Zone	67
Figure 21: Work Zone Using TB1.....	68
Figure 22: Work Zone Using TB4.....	68

1.7 TABLE OF TABLES

Table 1: Logic Assemblies Functions	32
Table 2: Logic Assemblies Part Numbers	32
Table 3: Function Module Functions	33
Table 4: Function Module Part Numbers.....	40
Table 5: Maximum Number of Logic Modules per String.....	45
Table 6: Power Supply Part Numbers	49
Table 7: Photoelectric sensor.....	52
Table 8: Reflector	52
Table 9: Sensor Valve Assembly	52
Table 10: Extension Cables	53
Table 11: Discharge Logic Assembly	54

1 SAFETY

1.1 CONVEYOR CONTROLS SAFETY GUIDELINES

The following basic conveyor control safety guidelines are recommended by FORTNA even though Business Partner may or may not purchase conveyor controls from FORTNA. The items listed deal with applications of controls equipment. **The actual installation of the equipment must always follow the National Electric Code and all other local codes.**

Start-up Warning Horn

Ideally, all conveyors should be within sight of the conveyor start pushbutton. This allows the operator to verify that no one is touching the conveyor or would be in danger if the conveyor were to start up.

If it is not possible to see the entire conveyor being started from the start pushbutton location, then some form of audible warning device is required. It could be a horn, buzzer, bell, or anything unique to that conveyor for that location. It should be loud enough to be heard at any point on the conveyor system. It should sound for approximately five seconds after the start pushbutton is pushed, prior to the actual running of conveyor. Any auxiliary equipment such as vertical lifts, turntables, etc., should also be included in the warning circuitry.

Conveyors that stop and restart under automatic control could also require a horn warning prior to restarting. If it is not easy to distinguish the difference between a fully stopped conveyor system and a momentarily stopped conveyor section, then it is advisable to add a warning horn. All conveyor sections that stop and restart automatically should be marked with appropriate signs or labels.

Start Pushbuttons

Start pushbuttons should be the flush type or guarded such that inadvertently leaning against them will not actuate the conveyor. They should be provided with a legend plate clearly defining which conveyors will be started.

Stop Pushbuttons

Stop pushbuttons should be the extended type such that any contact with it is sufficient to stop the conveyor. They would also be provided with a legend plate clearly defining which conveyors will be stopped.

Operator Controls

Additional operator controls should be designed into the system with the same guidelines that go into start and stop pushbuttons, depending upon their function. Devices which are repeated on multiple control stations, such as emergency stops, should be located at the same relative location on each station (such as lower right corner).

Emergency Stops

All locations where an operator must work directly at the conveyor may be subject to local safety codes requiring e-stops. It is the responsibility of the integrator to check with state and local authorities on the need and application of e-stops.

Emergency stops can be of the pushbutton or cable operated switch type. The pushbutton type should be a red, mushroom-head maintained pushbutton which requires resetting after it is actuated. Cable operated switches should trip by pulling the cable and require resetting at the switch.

Actuating an emergency stop must drop-out the start circuit, requiring restarting the system using the start pushbuttons provided.

An emergency stop should normally stop all conveyors in the system. Very large systems may involve dividing a system into zones of control based on proximity of personnel, safety hazards, walls obstacles, etc.

Controls Logic

Solid state controls logic devices, such as programmable controllers, are used extensively for conveyor control. They are very reliable, but a hardware failure or software bug would cause an output to function erratically. For this reason, start circuits, warning horn circuits, and emergency stops should usually be configured using conventional relay logic.

Safety Switches

All conveyor control cabinets and motors should be provided with safety (or disconnect) switches. These switches must have provisions for padlocking. As required for maintenance, equipment should be locked in the off position.

Special Devices

Special devices and equipment such as vertical lifts, turntables, high speed conveyors, etc., all have unique design and safety requirements. These should be looked at in each case to determine what the requirements might be.

1.2 DANGER AND RISK INFORMATION

The purpose of this chapter is to inform the personnel of any possible dangers and risks as well as of general and specific recommendations to eliminate or minimize said risks.

This chapter has information and instructions regarding:

- Dangerous situations that can arise during use and maintenance of the partly completed machine.
- Guards and safety devices adopted and their correct use.
- Residual risks and conduct to adopt (general and specific recommendations to avoid or reduce them).

This installation operation maintenance (IOM) manual briefly summarizes these instructions in the sections where the described situations occur.

Protective Devices

It is forbidden to use the partly completed machine or completed machine with no guards or protection devices, or with guards or protection devices deactivated. Ignoring the above can cause serious damage and/or accidents.

Operation Manual Illustrations

Some illustrations representing the conveyor equipment are shown without the protection guards or with the guards removed to show specific details. This is necessary for the sake of clarity in the description.

Some drawings represented in this manual are for visual reference only and as such not all drawings contain completed drawing information such as dimensions, notes, conveyor labels, or safety symbols.

1.3 SAFETY WHILE WORKING WITH THIS PRODUCT

Failure to follow the instructions and cautions throughout this manual and warning label on the conveyor may result in injury to personnel or damage to the equipment.

Your FORTNA conveyor is powered by a motor and can be stopped only by turning off electrical power to the motor. As with all powered machinery, the drive-related components – including sprockets, chains, shafts, universal joints, and pneumatic devices – can be dangerous. We have installed or provided guards to prevent accidental contact with these parts, along with warning labels to identify the hazards.

Special attention must be made to the following areas of this manual. Listed below are some symbols used throughout the manual to emphasize information of significant importance.

Special attention must be given to the following areas of this manual.



HAZARD OF ELECTRIC SHOCK

- Wear appropriate personal protective equipment (PPE) and use proper Lockout/Tagout procedures.
- The equipment must be installed, operated, and serviced by properly trained and qualified personnel.
- Turn off power supplying the equipment before working on or inside the equipment.

Failure to follow these directions will result in death or serious injury.



HAZARD TO EQUIPMENT OR PERSONNEL

- Do not eat food, drink, or smoke while operating or servicing the equipment/conveyor.
- Do not operate or service the equipment/conveyor if under the influence of drugs, alcohol, sedatives, or any other medication whether prescribed by a doctor or not.
- Do not operate or service the equipment/conveyor if sleep deprived or over fatigued.

Failure to follow these instructions can result in death, serious injury, or equipment damage.

WARNING

ELECTRICAL HAZARD

- Installation must be performed by a certified and licensed electrician.
- Electrical service must conform to local and national electrical codes and regulations.

Failure to follow these instructions can result in death, serious injury, or equipment damage.

WARNING

ELECTRICAL HAZARD

Electrical service must be performed by properly trained, qualified, and licensed personnel.

Failure to follow these instructions can result in death, serious injury, or equipment damage.

WARNING

HAZARD OF MOVING PARTS

- Make sure all personnel are clear of moving parts before starting the equipment/conveyor.
- All starting and stopping devices, and all loading and unloading areas should be kept free of obstructions.
- Keep hair, clothes, hands, and jewelry away from moving parts.
- Do not operate the equipment/conveyor without all motor guards being in place.
- Never touch, walk, ride, or climb on a moving belt or conveyor equipment.
- Never clear jams while the equipment is running.
- Do not pull-on equipment parts, such as belts, pulleys, or shafts, to assist slow-starting equipment.

Failure to follow these instructions can result in death, serious injury, or equipment damage.

WARNING

HEAVY EQUIPMENT

- Follow site safety procedures while moving equipment.
- Make sure to use moving equipment certified for the weight of the equipment.

Failure to follow these instructions can result in death, serious injury, or equipment damage.

WARNING

HAZARD TO PERSONNEL

- Only qualified and trained personnel should operate this equipment.
- All operating procedures must be followed.

Failure to follow these instructions can result in death, serious injury, or equipment damage.

WARNING

HAZARD OF INJURY TO PERSONNEL

- Do not remove or tamper with safety devices.
- Do not remove shields or panels, or bypass or otherwise disable interlocks while the unit is in operation.

Failure to follow these instructions can result in death, serious injury, or equipment damage.

CAUTION

HAZARD OF INJURY TO PERSONNEL

- Wear PPE when using compressed air.
- Do not direct compressed air toward yourself or another person.
- Do not use compressed air to clean yourself or clothing.
- Do not carry out practical jokes using compressed air.

Failure to follow these instructions can result in injury or equipment damage.

CAUTION

HAZARD OF INJURY TO EQUIPMENT OR PERSONNEL

Keep away from equipment as it is lowered into place.

Failure to follow these instructions can result in injury or equipment damage.

CAUTION

SHARP EDGES

- Never place hands or feet between the belt and guards.
- Remove sharp edges, protruding objects, and safely replace broken or worn parts promptly.

Failure to follow these instructions can result in injury or equipment damage.

CAUTION

HAZARD TO PERSONNEL AND EQUIPMENT

Follow site-specific safety guidelines.

Failure to follow these instructions can result in injury or equipment damage.

CAUTION

SOUND HAZARD

Prolonged exposure to noise above 90 decibels may cause permanent hearing damage. Hearing protection must be worn by personnel exposed to noise of 90 decibels or greater.

Failure to follow these instructions can result in injury or equipment damage.

CAUTION

HAZARD TO PERSONNEL OR EQUIPMENT

Troubleshooting must be performed by qualified and trained personnel.

Failure to follow these instructions can result in injury or equipment damage.

NOTICE

HAZARD OF EQUIPMENT DAMAGE

- The lifting and rigging equipment used to move the conveyors must be certified and rated to handle the load weight and must be maintained in proper working order.
- Before lifting, attach the load lifting and rigging equipment so that the conveyors are supported about their center of gravity.

Failure to follow these instructions can result in property damage or equipment damage.

NOTICE

EQUIPMENT DAMAGE

- Do not load or use the conveyors beyond the specified design limits.
- Always place packages directly onto the conveyor surface.
- Do not drop packages onto the conveyor from a height greater than 30 cm (12 in.) above the conveying surface.







NOTICE

Failure to follow these instructions can result in property damage or equipment damage.

1.4 SYMBOLS USED THROUGHOUT THIS MANUAL

Symbols are used throughout the manual to emphasize information of significant importance.

Symbol	Type	Definition
	ATTENTION	Symbol is used to identify important warnings for the safety of the operator and/or conveyor equipment.
	FORBIDDEN (MUST NOT / SHALL NOT)	Symbol is used to identify operations that must not be performed or behaviors that must not be adopted as they could cause injury to personnel or damage to the conveyor equipment.
	OBLIGATION (MUST DO / SHALL DO)	Mandatory action symbols are used to draw attention to a supplementary sign for a specified mandatory action. The mandatory action symbol is used to identify particularly important information inside the manual. The information also regards the safety of personnel involved use of the conveyor equipment.
	OBLIGATION TO READ THE INSTRUCTION MANUAL	To use the conveyor equipment safely, it is mandatory to read and understand the manual and accompanying documentation in its entirety.
	OBLIGATION TO READ THE TECHNICAL MANUAL	To use the conveyor equipment safely, it is mandatory to read and understand the manual and accompanying documentation in its entirety. Before service to use the conveyor equipment safely, it is mandatory to read and understand the manual and accompanying documentation in its entirety.

1.5 OBLIGATIONS



Listed below are instructions and symbols used throughout the manual to emphasize information of significant importance.

Must Do/Should Do to avoid hazard to personnel or equipment!

- Carry out maintenance operations with the conveyor equipment switched off.
- Parts over 18kg (40lbs) should be lifted by two people.
- A step ladder must be used when performing maintenance or cleaning on items that cannot be reached from floor level.



- Must tie up long hair or long beards, avoid wearing scarves or other clothes that may get trapped in the moving parts of the conveyor. All loose clothing, long hair, long beards, and jewelry must be kept away from moving equipment.

- Must remove jewelry such as bracelets, rings or necklaces that may get trapped in moving parts, thus creating a risk for the operator.



- Must always perform interventions on the electrical system components in the absence of voltage (main switch off).

- Must make sure that no-one is standing in the danger zones during the start-up and operation of the conveyor machine.

- Must use extreme caution to avoid injury or property damage during use of the conveyor equipment.
- Must know the location and operation of the stopping device.
- Must comply with instructions and provisions given by the employer, managers, or supervisors, to ensure personal and collective safety.
- Must make proper use of equipment, tools, substances, and dangerous products, means of transport and other working machinery, as well as safety devices.
- Shall make correct use of all personal protective equipment they have been properly trained and provided with.
- After maintenance, guards must be **REPLACE** immediately.
- Keep ALL warning labels clean and clear of any obstructions.
- Must be trained to never remove, deface, or paint over symbols or labels of any kind. Any damaged label can be replaced by FORTNA by contacting Lifecycle Performance Services.
- It is very important to instruct personnel in proper conveyor use, including the location and function of all controls.
- Special emphasis must be given to emergency stop procedures.
- It is important to establish work procedures and access areas, which do not require any part of a person to be under the conveyor.
- After the power source is turned off and locked out trained and qualified maintenance technicians are to remove blockage or jams from the conveyor equipment.
- Maintain enough clearance on each side of all conveyor units for safe adjustment and maintenance of all components.
- Provide crossovers or gates at sufficient intervals where needed to eliminate the temptation for personnel to climb over or under any conveyor.
- Use the conveyor equipment within the approved environmental conditions.



- **Must Do, BEFORE** performing maintenance on the conveyor, make sure the start-up controls are locked out and cannot be turned on by any person other than the one performing the maintenance.
- If more than one crew member is working on the conveyor, **EACH CREW MEMBER MUST HAVE A LOCK ON THE POWER LOCKOUT.**

- Maintain enough clearance on each side of all conveyor units for safe adjustment and maintenance of all components.
- All pneumatic devices must be de-energized, and air removed to prevent accidental cycling of the device while performing general maintenance.
- Make sure all personnel are clear of all conveyor equipment before restarting the system.
- Continuous handling equipment shall be kept in proper working conditions and maintained in accordance with the manufacturer's instructions.
- Inspection, adjustment, maintenance and cleaning of moving parts shall be carried out regularly in a safe manner according to the manufacturer's instructions.
- If possible, inspection and adjustment of continuous mechanical handling equipment, in motion or in use, shall only be carried out with guards in position.
- Displacing or removal of a guard and/or neutralization of a safety device shall be carried out in accordance with alternate safeguarding or lockout/tagout procedures (OSHA 29 CFR 1910.147 and 29 CFR 1910.333(b)(2) for further information visit <https://www.osha.gov>.
- Repairs and removal of protective enclosures or panels shall only be carried out after stopping the equipment and starting devices have been rendered inoperative by qualified and trained personnel.



- Watch for nip points or pinch points. A pinch point hazard is a common class of mechanical hazard where injury or damage may be done by one or more objects moving towards each other, crashing, or shearing whatever comes between them. A nip point is a type of pinch point involving rotating objects, such as gears and pulleys.



- **Must Do, BEFORE** restarting a conveyor, which has been stopped because of an emergency, an inspection of the conveyor must be made, and the cause of the stoppage determined. The starting device must be locked out before any attempt is made to correct the cause of stoppage.

- Make correct use of all personal protective equipment that they have been provided with.
- Know the workplace and traffic routes, and all required protection/guarding of nearby hazardous equipment.
- All employees that come in contact with the equipment must be warned of the dangers of an unexpected start.
- The user shall be careful to ensure a regular feed, avoiding overloading.
- All loading and working places, passageways, shall be kept clear.
- **Must Do, BEFORE** servicing or performing any work in the motor control panel, disconnect and padlock out air and the main incoming service. If **ONLY** the panel disconnect is off, the incoming side will still be hot.



- All safety rules must be observed when working with, on or at the conveyor system in whatever way. This includes reading all installation, operation, maintenance, or technical manuals.

- Know workplace and traffic routes may require additional protection/guarding if nearby hazardous equipment.
- Know that IntelliROL motorized rollers can become hot!
- **Must Do**, know IntelliROL equipment starts and stops without warning.



- Employees that come in contact with the equipment must be warned of the dangers of an unexpected start. Hands can be crushed between products or products and channels.

- Before servicing or performing any work in the motor control panel, disconnect and lock out air and the main incoming service. If only the panel disconnect is off, the incoming side will still be hot.

1.6 PROHIBITIONS



Listed below are instructions and symbols used throughout the manual to emphasize information of significant importance. **Must Not Do/ Shall Not Do** to avoid hazard to personnel or equipment!

- **Must Not**, remove or modify the safety or signaling devices without authorization.
- **MUST Not**, use conveyor equipment with no guards or protection devices, or with guards or protection devices deactivated. Ignoring the above can cause serious damage and/or accidents.
- **Must Not**, remove, deface, or paint over symbols or labels of any kind. Any damaged label can be replaced by FORTNA by contacting Lifecycle Performance Services.
- **Must Not**, convey hazardous materials.



- **Must Not**, Walking or riding on a conveyor equipment /moving conveyor must be prohibited. No person shall ride, sit, or stand on a conveyor under any circumstances.
- **MUST Not**, remove or install heavy parts whilst anyone is working on the floor level below the parts to be moved. This will help stop accidental falling of heavy parts onto people.
- **Must Not** carry out, upon their own initiative, operations or maneuvers they are not in charge of and that can jeopardize their own safety and that of other workers.
- **Must Not**, wear bracelets, rings or necklaces that may get trapped in moving parts, thus creating a risk for the operator.
- **Must Not**, modification of the design or configuration of the equipment may lead to new hazards or higher risk that are not reduced adequately by the risk reduction measures of the manufacturer.
- **Must Not**, replace or modify the speed of the conveyor equipment components without being authorized by a manager.
- **Must Not**, modify the conveyor equipment operating cycle.
- **Must Not** modify the connections to exclude the internal safety devices.
- **Must Not**, use the conveyor equipment if not properly incorporated within the final line, according to current regulations.
- **Must Not** use the conveyor equipment or its components as point of support even if not operational (risk of falls and/or risk of damaging the components themselves).
- **Must Not**, use the conveyor equipment outside of the admitted environmental conditions.
- **Must Not** touch Motorized rollers as they can become **hot!**
- **Must Not**, touch any type of Motor as the motor may be **hot!**
- **Must Not**, clear jams while the equipment is running.
- **Must Not**, lubricate moving parts.
- **Must Not**, do not pull-on equipment parts, such as belts, pulleys, or shafts, to assist with slow starting equipment.

1.7 PROPER LABELS FOR CONVEYOR TYPES

FORTNA recommends proper labels for conveyor types. Shown below are some samples of labels applicable to conveyor standards.

Package Conveyors

SAFETY IS IN YOUR HANDS

- Do Not Climb, Sit, Stand, Walk, Ride, or Trip on the Conveyor at Any Time
- Do Not Perform Maintenance on Conveyor Until Electrical, Air, Hydraulic and Gravity Energy Sources Have Been Locked Out and Blocked
- Operate Equipment Only With All Adjustment Covers and Guards in Place
- Do Not Load a Stopped Conveyor or Overload a Running Conveyor
- Ensure That All Personnel Are Clear of Equipment Before Starting
- Allow Only Authorized Personnel to Operate or Maintain Material Handling Equipment
- Do Not Modify or Misuse Conveyor Controls
- Keep Clothing, Body Parts and Hair Away from Conveyors
- Remove Trash, Rags and Other Debris Only When Power is Locked Out
- Ensure That All Controls and Pull Cords are Visible and Accessible
- Know the Location and Function of All Stop and Start Controls
- Report All Unsafe Conditions

POST IN PROMINENT AREA

Product: Unit Handling
Equipment: Motor Driven Live Roller Conveyors

To be placed along both sides of these conveyors since these conveyors provide surfaces and profiles attractive, but hazardous, for climbing, sitting, walking, or riding.

To be placed along the sides of these conveyors to warn personnel that the conveyor can start automatically.

"A"
SPACE UP TO A MAXIMUM OF 20 FT. CENTERS (BOTH SIDES)

"C"
SPACE UP TO A MAXIMUM OF 20 FT. CENTERS (BOTH SIDES)

Optional Label to be placed either on the side or top of rails when space available does not permit application of the larger label.

"B"
SPACE UP TO A MAXIMUM OF 20 FT. CENTERS (Side or top surface of both rails)

"D"
SPACE UP TO A MAXIMUM OF 20 FT. CENTERS (Side or top surface of both rails)

"B"/"D" OPTIONAL

20' FT. MAXIMUM

"A"/"B"
"C"/"D"

NOTE: Due to the design of these conveyors, there may not be room on the side rails to place the larger labels. In this case, the smaller labels may be used. Optionally, they may also be placed on the top surface of both rails. The key is the space available and visibility by operators and maintainers.

CEMA - August, 2010 UH-8

CEMA Safety Labels Placement Guidelines

Product: Unit Handling Equipment
Equipment: Live Roller Conveyors - Belt Driven

To be placed on conveyors where there are exposed rotating parts which must be guarded to reduce friction, i.e. rollers, pulleys, shafts, sheaves, etc.

To be placed on removable guards to warn that operation of the machinery with guards removed will expose rollers, belts, gears, shafts, pulleys, sheaves, etc. which create hazards.

To be placed on removable guards to warn that operation of the machinery with guards removed would expose rollers, belts, gears, shafts, pulleys, sheaves, etc. which create hazards.

"A"
LOCATE AT TERMINAL ENDS (BOTH SIDES)

"B"
SPACE UP TO A MAXIMUM OF 20 FT. CENTERS (BOTH SIDES)

"C"
LOCATE ON DRIVE GUARDS AND DRIVE SHEET GUIDES

"D"
LOCATE ON DRIVE SECTION (BOTH SIDES)

GENERAL PURPOSE LABEL TO WARN MAINTENANCE PERSONNEL THAT CONVEYORS SHOULD BE SHUT OFF AND LOCKED OUT PRIOR TO SERVICING. Examples: Drive, Take-Up, Lubrication points, which require guard removal.

UH-4

CEMA Safety Label Placement Guidelines

Product: Unit Handling Equipment
Equipment: Belt Conveyors - End Driven

To be located on conveyors where there are exposed moving parts which must be guarded to reduce friction, i.e. rollers, pulleys, shafts, sheaves, etc.

To be placed along both sides of these conveyors since these conveyors provide surfaces and profiles attractive, but hazardous, for climbing, sitting, walking, or riding.

To be placed on removable guards to warn that operation of the machinery with guards removed would expose rollers, belts, gears, shafts, pulleys, sheaves, etc. which create hazards.

"A"
LOCATE AT TERMINAL ENDS (BOTH SIDES)

"B"
SPACE UP TO A MAXIMUM OF 20 FT. CENTERS (BOTH SIDES)

"C"
LOCATE ON DRIVE GUARDS

"D"
LOCATE ON DRIVE SECTION (BOTH SIDES)

GENERAL PURPOSE LABEL TO WARN MAINTENANCE PERSONNEL THAT CONVEYORS SHOULD BE SHUT OFF AND LOCKED OUT PRIOR TO SERVICING. Examples: Drive, Take-Up, Lubrication points which require guard removal.

UH-5

2 ABOUT THIS MANUAL

2.1 IOM PURPOSE

It is the intent of FORTNA, through this manual, to provide information that acts as a guide in the installation, operation, and maintenance of FORTNA conveyors.

2.2 MANUAL SCOPE

This manual describes basic installation practices, assembly arrangements, preventive maintenance, and assists in replacement parts identification.

2.3 DOCUMENT OVERVIEW

This service manual is intended for use by personnel who are knowledgeable of installation and safe working practices on conveyor systems.

Not all applications and conditions can be covered; therefore, this manual is to be used ONLY as a guide. Proper training of operating and maintenance personnel is required by the owner/operator of the equipment.

If additional copies of this manual are needed or if you have any question concerning the conveyor, please contact your FORTNA Distributor or FORTNA Lifecycle Performance Services at 231-798-4547 or visit FORTNA at fortna-conveyor.com for maintenance videos and other application information.

2.4 MANUAL STRUCTURE

You should receive separate documentation for each product line of FORTNA conveyor implemented in your installation. You can identify the respective product lines on the back of the folder or on the cover sheet of the IOM (Installation Operation Maintenance Manual).

Note:

- Pay attention to the safety instructions!
- Prior to working at or in the immediate vicinity of the system it is recommended that you make yourself familiar with the safety instructions included in the present document!

3 POLICIES

3.1 CONVEYOR EQUIPMENT WARRANTY

FORTNA warrants that the material and workmanship entering into its equipment is merchantable and will be furnished in accordance with the specifications stated.

FORTNA agrees to furnish the purchaser without charge any part proved defective within 2 years from date of shipment provided the purchaser gives FORTNA immediate notice in writing and examination proves the claim that such materials or parts were defective when furnished. There are no warranties which extend beyond the description on the face hereof. Consequential damages of any sort are wholly excluded.

The liability of FORTNA will be limited to the replacement cost of any defective part. All freight and installation costs, relative to any warranted part, will be at the expense of the purchaser. Any liability of FORTNA under the warranties specified above is conditioned upon the equipment being installed, handled, operated, and maintained in accordance with the written instructions provided or approved in writing by FORTNA.

The warranties specified above do not cover, and FORTNA makes no warranties which extend to damage to the equipment due to deterioration or wear occasioned by chemicals, abrasion, corrosion or erosion; Purchaser's misapplication, abuse, alteration, operation or maintenance; abnormal conditions of temperature or dirt; or operation of the above rated capacities or in an otherwise improper manner.

THERE ARE NO WARRANTIES, EXPRESSED OR IMPLIED, INCLUDING, BUT NOT LIMITED TO, WARRANTIES OF MERCHANTABILITY OR FITNESS FOR A PARTICULAR PURPOSE, EXTENDING BEYOND THOSE SET FORTH IN THIS STATEMENT OF WARRANTY.

3.2 ENVIRONMENT STANDARDS

FORTNA conveyor equipment is designed to be installed in a clean, dry warehouse environment. Exposure to extreme humidity, direct sunlight, blowing dirt or rain can permanently damage some components of FORTNA Conveyor. In particular, the curing agents in concrete are known to attack and degrade the urethane conveyor components.

When installing conveyor on a new construction site, be sure that the concrete is properly cured before setting conveyor on it. In addition, if conveyors are stored in proximity to curing concrete, proper ventilation must be used to direct the curing agent fumes away from the conveyor.

Failure to comply with these guidelines will void the FORTNA warranty on any failed components that result from these environmental issues.

3.3 INDUSTRIAL ENVIRONMENT

All technologies are designed to function in "normal" industrial environments. Chemical vapors, lubrication, excessive dust, high or low heat and moisture may affect their operation and void the equipment warranty. Some paint fumes, fresh concrete and other concentrations of airborne fumes have been known to adversely affect the life of many conveyor components and will void the equipment warranty.

4 CRUZCONTROL CONCEPT

The CRUZcontrol product line is a set of components used to setup accumulation and discharge on NBC conveyor. It consists of logic modules that detect product that control accumulation, function modules that release product, and 24VDC power supplies. There are accessories such as sensors and cables to ease installation and interfacing.

CRUZcontrol is a 24VDC system that will automatically start accumulation when product reaches the end of an accumulation line. When a release signal is applied to a function module that is installed at the discharge end of an accumulation line, the product will begin to release. Product will continue to release until the signal is removed. The type of accumulation that occurs is based on the mode that the logic assembly has been configured for. The type of product release is based on logic assembly mode and function module setup.

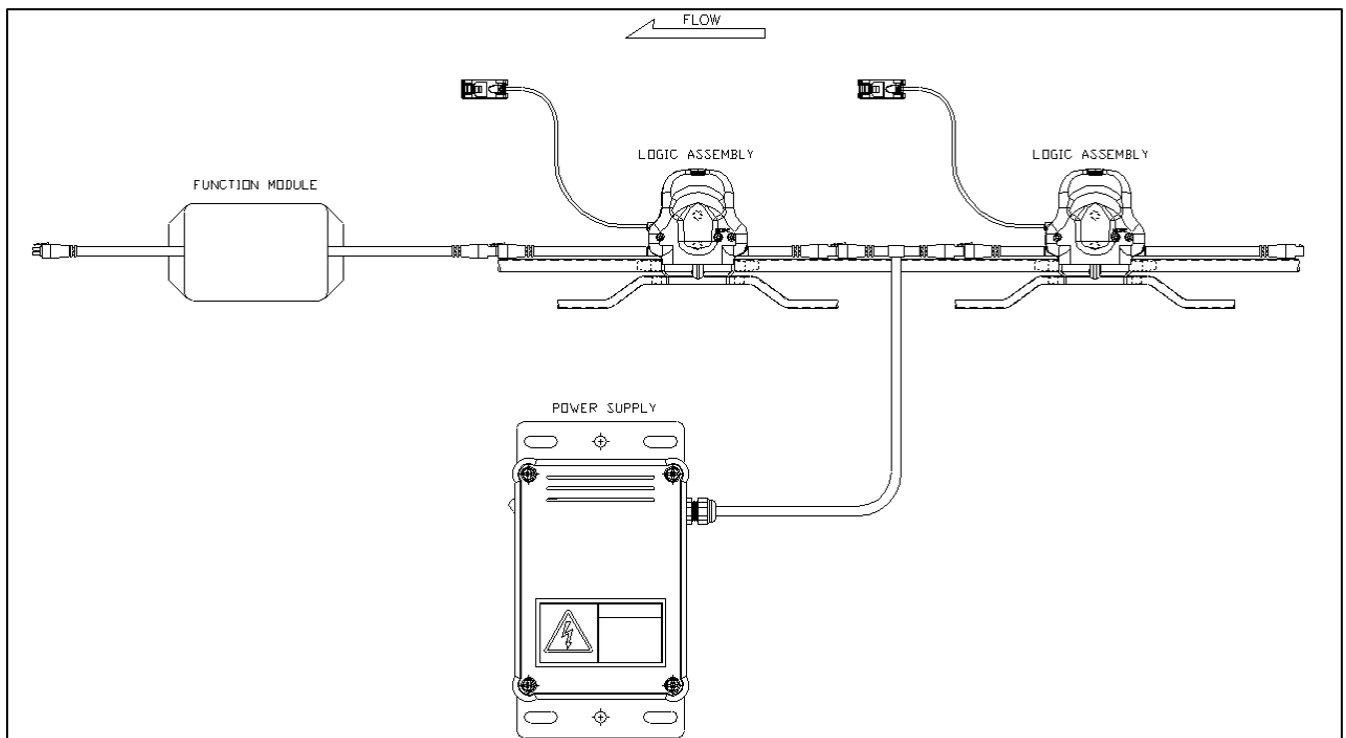

Figure 1: Basic Concept Layout

4.1 CRUZCONTROL LOGIC CAUTIONS

CAUTION

- CRUZcontrol Logic Assemblies are designed to be fail-safe. A loss of module power, a disconnected or severed cable, or a dirty or failed photoelectric sensor will all result in the stopping of a zone, initiating accumulation beginning from the affected zone.
- In Progressive Logic mode, failure of a Logic Assembly to function properly could possibly result in product accumulating with zones not stopping as required. While this should be unlikely due to the fail-safe nature of the Logic Assembly, a product jam preventing product from blocking a zone sensor would also result in a zone not functioning. The effects of such a failure should be considered. This type of failure could result in excessive line pressure, eventually causing the product to push through the discharge zone of the conveyor. If needed, jam detection sensors should be used to minimize the effects of such a failure.
- Conveyors should not be operated with 100% of the logic modules switched to the progressive mode in the contact accumulation mode. This could cause line pressure issues if there is a jam since in the release mode, progressive ignores the photo sensors and dumps all the zones at once, in the same way slug discharge operates. **In the progressive release mode for contact accumulation, it is extremely important to set every 5th logic module to basic. Do not set all logic modules to progressive unless your line is under 20' long.** This limits a product jam condition line pressure to 16' of conveyor. Failure to set every fifth logic module to basic can result in extreme line pressures that can damage your conveyor, product and could cause injury.
- CRUZcontrol provides the ability to slug release. If the line is set to Slug Release, all affected zones will run immediately, regardless of downstream conditions, resulting in the immediate release of product with little or no gaps. Both the Basic and Progressive Logic modes will release at the maximum possible discharge rate when slug release is enabled. Slug release does create a situation where a product jam will result in excessive line pressure buildup. If the slug release feature is used, it should be used with caution, and for a limited number of successive accumulation zones.
- The “Air to Brake” operation requires a consistent supply of air to operate safely and predictably. The system air supply should be monitored to ensure that adequate air pressure is available before operating conveyors.

4.3 ABBREVIATIONS, ACRONYMS, AND TERMS

Logic Assembly

The logic assembly is to set up the type of automatic accumulation and discharge of product on the conveyor.

Function Module

The function module provides electrical isolation for external signals used to control a CRUZcontrol system.

Downstream or Upstream

In this manual, it is always in reference to conveyor flow.

OFF

Off indicates a logical low signal and/or no power. For example, if a logic line is OFF, there is no power on the logic line.

ON

On indicates a logical high signal and/or powered. For example, if a slug line is ON, then there is power on the slug line.

Zone status

The zone is considered full if the local zone's sensor detects a package. The zone is empty if it does not detect a package.

JP#, #-#

JP stands for "jumper terminal" and the number indicates which jumper terminal is being referenced. The "#-#" refers to the pins that are connected by the actual jumper. NC means the jumper is not connected to any terminal.

Ex. jumper terminal #1 pins 1 & 2 (JP1, 1-2)

TB#, #-#

TB stands for "terminal block" and the number indicates which terminal block is being referenced. The "#-#" refers to the pins that are being used on that terminal block.

Ex. terminal block #1 pins 1 & 2 (TB1, 1-2)

4.5 CRUZCONTROL LOGIC TYPES

The following describes the differences between the two logic alternatives. The descriptions as written more closely describe product movement on NBC-N non-contact accumulation conveyor, where accumulated product is brought to a full stop. NBC-C conveyor, where a stopped zone does not have brakes but becomes gravity flow, will have very different product flow characteristics. The coasting of product through gravity zones will result in gaps closing up and could yield higher throughput rates regardless of the type of logic selected.

4.6 BASIC LOGIC

Accumulation in Basic Logic Mode

Any sensor detecting product will cause the upstream zone to go into accumulation mode. Once a zone is in accumulation mode, any product sensed in that zone will be accumulated until product is not sensed in the downstream zone.

Note that with Basic Logic products being transported on the conveyor are separated by a gap of at least one zone length. This will reduce the transportation throughput capacity of the conveyor. The rate at which product is introduced onto an accumulation conveyor of this type must not exceed the transportation capacity of the conveyor.

Single Discharge from Basic Logic

A Singulation Release signal given to the function module will release product from the discharge zone. As released product clears the discharge photoelectric sensor, product stopped at the next upstream zone is released. This will create a one-zone length gap between all released products; assuming conveyor speeds (accumulation conveyor and downstream conveyor) are identical.

Slug Discharge from Basic Logic

A slug release signal given to the function module will release product in all connected zones simultaneously, resulting in the release of product with little or no gaps.

Configuration Options

The selection of Basic Logic mode and Progressive Logic mode can be intermixed. An example of where this would be advantageous would be the selection of one Basic Logic mode zone at the end of a long length of Progressive Logic Mode conveyor. The Progressive Logic mode would allow the conveyor to receive and transport product at higher throughput rates, while the Basic Logic mode discharge zone would singulate product being released.

4.7 PROGRESSIVE LOGIC

Accumulation in Progressive Logic Mode

A zone is not set to accumulate product until all downstream zones hold accumulation product.

Note that with Progressive Logic products being transported on the conveyor can remain tightly packed, without any gaps being created.

Discharge from Progressive Logic

Progressive mode only allows slug release. All zones connected together will be activated simultaneously. A Release signal given to the function module will release product in all zones, resulting in the release of product with little or no gaps. A release signal can be given to the function module on TB1- single release or TB2- slug release, with no difference in operation.

4.8 CRUZCONTROL COMPONENTS

CRUZcontrol LOGIC ASSEMBLY

The CRUZcontrol Logic Assembly consists of a polarized retro-reflective type photoelectric sensor, pneumatic valve and logic module integrated into one assembly.

The photoelectric sensor will function reliably on conveyor widths up to 34 inches between frames. The sensor is polarized and is not affected by shiny surfaces. On NBC™ applications, the reflector is mounted with a 6-inch offset from the photoelectric sensor, so that the sensor scans across the conveyor on a slight angle.

The sensor bracket as provided allows for easy adjustment of the sensor. An amber LED output indicator on the back of the sensor aids in the adjustment of the sensor. The LED is off if the sensor is not aligned, flashes if functional but marginally aligned, and is on steady if properly aligned. A green LED indicates power on status.

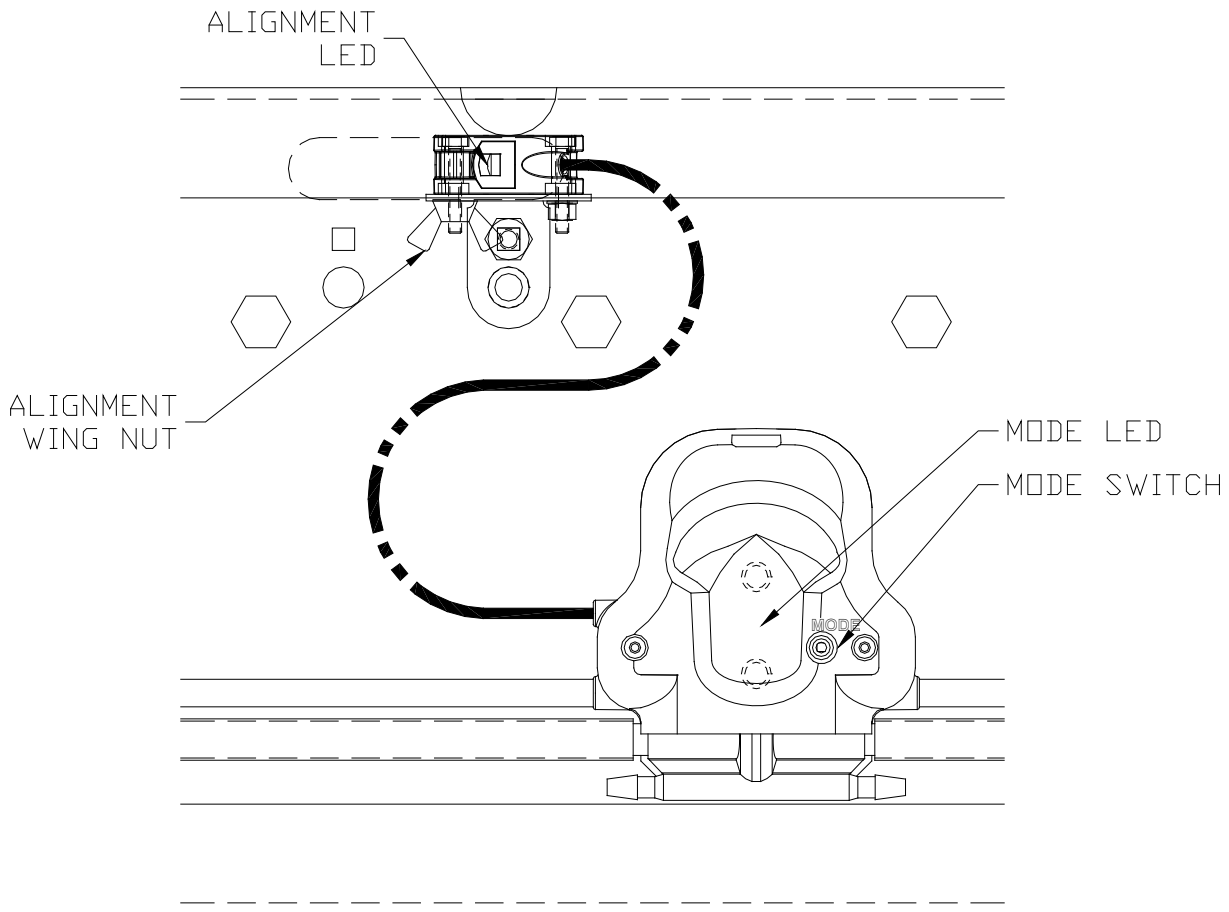

Figure 2: Logic Assembly Mode & Alignment

4.9 LOGIC ASSEMBLY TYPES

The CRUZcontrol Logic Assembly 1114947 provides an “air to brake” logic output utilizing a normally open pneumatic valve. The pneumatic valve is energized for a zone to be running.

The CRUZcontrol Logic Assembly 1114948 provides an “air to drive” logic output utilizing a normally closed pneumatic valve. The pneumatic valve is energized for the zone to be running.

Logic Assembly Functions

The CRUZcontrol Logic Assembly comes with a momentary button on the front of the housing allowing for selection of either Basic Logic or Progressive Logic mode. A Mode LED indicates either Basic (green) or Progressive (amber) has been selected. Pressing and then releasing the button toggles between the two modes.

Table 1: Logic Assemblies Functions

Function	Basic Logic	Progressive Logic
Single Accumulate	Yes	No
Slug Accumulate	No	Yes
Single Release	Yes	No
Slug Release	Yes	Yes

Logic Assembly Part Numbers

Table 2: Logic Assemblies Part Numbers

Part Number	Description	Used with
1114947	Basic/Progressive Logic Module, Air to Brake,	NBC straight conveyor
1114948	Basic/Progressive Logic Module, Air to Drive	NBC Curves and V-Belt conveyor

4.10 FUNCTION MODULES

The Function Module provides electrical isolation for external controls and creates controllable zones to facilitate CRUZcontrol applications.

Function Module Types

There are two different Function Modules, each providing certain of functions.

Table 3: Function Module Functions

	Single Release	Slug Release	Pulsed Release	Zone Stop	Zone Delay	Logic Interrupt	Slug Interrupt	Zone Status
Full Function Module	x	x	x	x	x	x	x	x
Release Function Module	x	x		x		x	x	

Function Module Functions

Single Release	
Definition	Only the discharge zone releases, when the discharge photoeye is clear the next zone releases. The discharge zone will continue to release until the release signal is removed.
Configuration	The logic assemblies must be in basic mode (mode LED is green). When releasing from the discharge end of the conveyor line all jumper terminals should be on pins 1-2.
User Action	Apply a high (24Vdc/120Vac) release signal to TB1, 1-2 if using isolated inputs Or Apply a high (24Vdc) release signal to TB4, 3 if using non-isolated input.

Slug Release	
Definition	All zones that are connected in one continuous string release at the same time regardless of zone status. All zones will continue to release until the release signal is removed.
Configuration	The logic assemblies can be in basic or progressive mode. When releasing from the discharge end of the conveyor line all jumper terminals should be on pins 1-2.
User Action	Apply a high (24Vdc/120Vac) release signal to TB2, 1-2 if using isolated inputs, the logic assemblies can be in basic or progressive mode. Or Apply a high (24Vdc) release signal to TB4, 3 if using non-isolated inputs, the logic assemblies must be in progressive mode.

Pulse Release	
Definition	Upstream Logic Assembly releases for a length of time set by ZS ON (0-20s) and then accumulates for length of time set by ZS OFF (0-20s).
Configuration	When releasing from the discharge end of the conveyor line jumper terminal JP3, NC - all other jumper terminals should be on pins 1-2.
User Action	Apply a high (24Vdc/120Vac) release signal to TB1, 1-2.

Logic Interrupt	
Definition	Breaks release signal from downstream Logic Assembly. Upstream zones are forced to accumulate despite downstream zone status.
Configuration	When using TB1 to release set jumper terminal JP3, 2-3 When using TB4 to release set jumper terminal JP4, 2-3.
User Action	Apply a high signal to TB1 (24Vdc/120Vac) or TB4 (24Vdc). No action required

Zone Delay	
Definition	After the downstream zone clears, the upstream zone releases only after the time set by the Logic Delay potentiometer has expired.
Configuration	Adjust Logic Delay potentiometer from 0 to 20 seconds.
User Action	No action required

Slug Interrupt Downstream	
Definition	Logic Assemblies downstream of the Function Module will not slug release when the Slug Release signal goes high.
Configuration	JP1, 2-3 all other jumper terminals should be on pins 1-2.
User Action	No action required

Slug Interrupt Upstream

Definition	Logic Assemblies upstream of the Function Module will not slug release when the Slug Release signal goes high.
Configuration	JP2, 2-3 all other jumper terminals should be on pins 1-2.
User Action	No action required

Zone Status Indication	
Definition	Indicates full or empty status of the downstream zone on TB3.
Configuration	JP4, 1-2 and JP5, 1-2 for logic status or 2-3 for sensor status, all other jumper terminals should be on pins 1-2.
User Action	<p>Connect to TB3 for zone status.</p> <p>The output transition of the Zone Status from OFF to ON or ON to OFF can be delayed by the Zone Status ON and Zone Status OFF Delay potentiometers. This is typically used to indicate a zone is full only after a product is detected for a period of time.</p>

4.11 TERMINAL AND JUMPER DESCRIPTIONS

Terminal Descriptions	
TB1	Single release, Logic interrupt, Pulse release.
	This terminal is an isolated input; it must be used when signal voltage is from a supply that is different than the supply powering CRUZcontrol logic assemblies. It can be used when signal voltage is from same power supply that is powering CRUZcontrol logic assemblies.
TB2	Slug release.
	This terminal is an isolated input; it must be used when signal voltage is from a supply that is different than the supply powering CRUZcontrol logic assemblies. It can be used when signal voltage is from same power supply that is powering CRUZcontrol logic assemblies.
TB3	Zone Status (TB3 only available on full function module)
	This terminal is an isolated output; it must be used when signal voltage is from a supply that is different than the supply powering CRUZcontrol logic assemblies. It can be used when signal voltage is from same power supply that is powering CRUZcontrol logic assemblies.
TB4	Inputs
	This terminal is a non-isolated input; it must be used when signal voltage is from same power supply that is powering CRUZcontrol logic assemblies.
TB5	Outputs
	This terminal is a non-isolated outputs; output signal voltage is from same power supply that is powering CRUZcontrol logic assemblies.

Jumper Descriptions	
JP1	Downstream slug control
	Pins 1-2 = slug pass through Pins 2-3 = slug interrupt Pins 3-4 = slug interrupt Pins 4-5 = singulation to slug crossover Pins NC = slug interrupt
JP2	Upstream slug control
	Pins 1-2 = slug pass through Pins 2-3 = slug interrupt Pins NC = slug interrupt
JP3	Release control at TB1
	Pins 1-2 = single release Pins 2-3 = logic interrupt Pins NC = pulsed released
JP4	Release control at TB4
	Pins 1-2 = single release Pins 2-3 = logic interrupt Pins NC = zone status input (determined by JP5)
JP5	Zone Status control (JP5 only available on full function module)
	Pins 1-2 or NC = downstream logic status Pins 2-3 = downstream sensor status

4.12 USE OF 115VAC CONTROLS

Important information regarding the use of 115 VAC controls:

These Function Modules will accept 115 VAC level control inputs. There are some cautions that must be observed to avoid Function Module hardware failure.

Function Module signal inputs are protected against 500 volt spikes. 115 VAC control signal wiring run in conduit along with higher voltage motor wiring could experience voltage spikes that exceed the 500 volt limit. This can be prevented by running control wiring in separate conduit from motor wiring. Additional protection for the Function Module inputs can be achieved by using an MOV (metal oxide varistor) placed across the input terminals within the Function Module. Suggestions of suitable MOV's would include Panasonic ERZV07D241 or Littlefuse V250LA2.

Long conduit runs with motor wiring for multiple motors, and the use of variable frequency drives, all contribute to electrical noise, with a good potential for high voltage spikes. If there is any doubt, the control signals to the Function Modules should be run in conduits separate from motor wiring.

The Function Module signal inputs have high impedance. When connected to some output devices, such as some PLC triac outputs, the inputs could sense an on state even if the output connected to it is not on. This can be corrected by adding additional loading to the output. This can be done by adding a loading resistor, placed across the output terminals. Do not put this resistor inside of the Function Module. The size and wattage rating of the resistor would depend on the output characteristics of the PLC card. A typical value would be 10,000 ohms (10K ohms) and 2 watts. The resistor would dissipate 1.32 watts at 115 VAC, so it will get warm.

Function Module Part Numbers

Table 4: Function Module Part Numbers

Part Number	Description
1116731	Full Function Module
1116732	Release Function Module

Figure 3: Function Modules

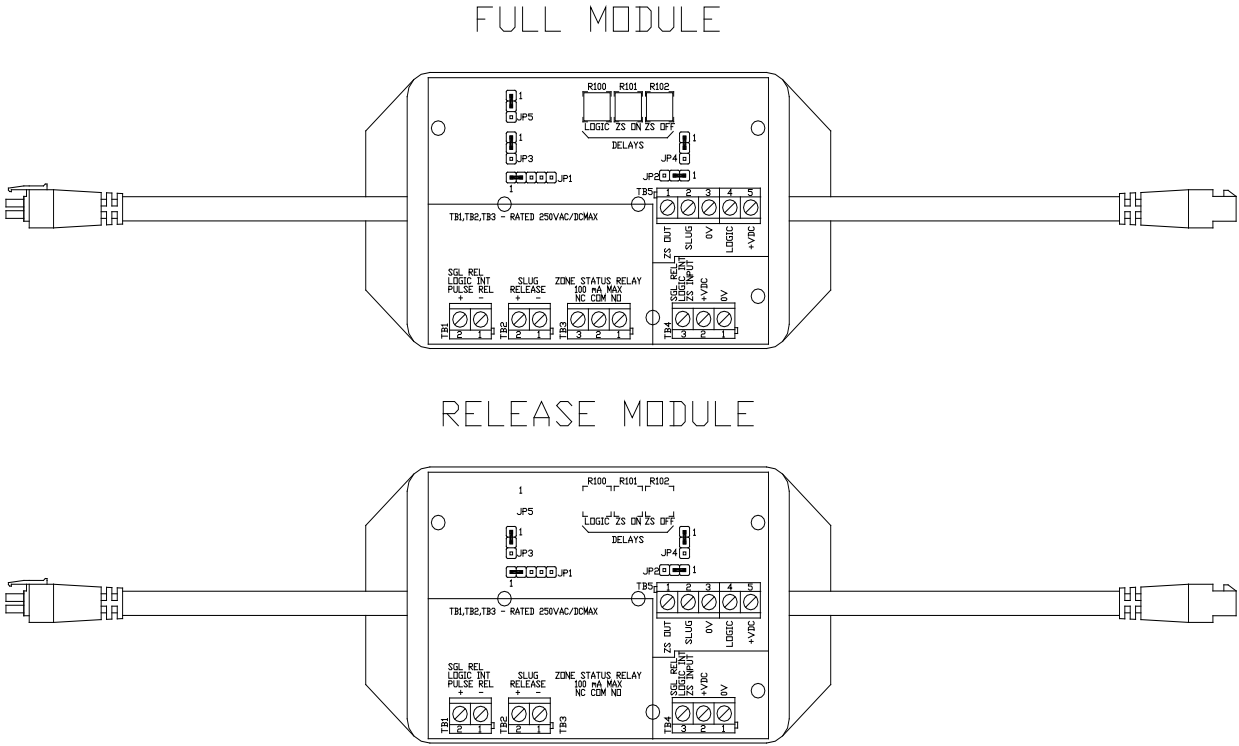

Figure 4: Full Function Module Board Layout

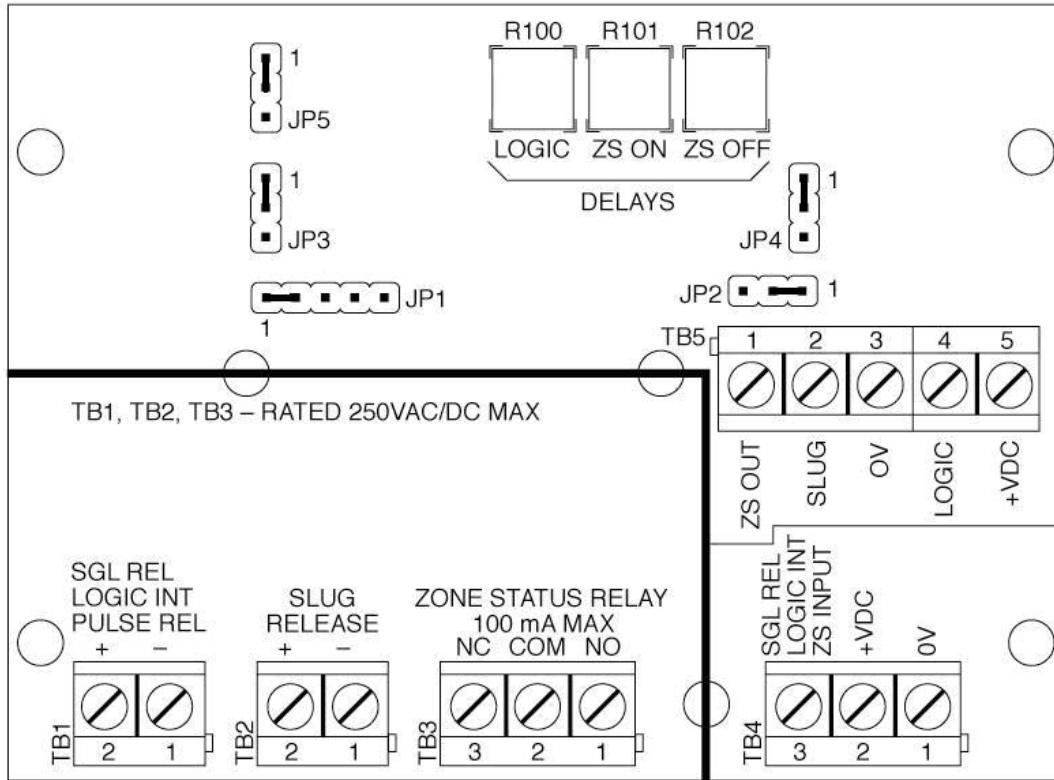

Figure 5: Full Function Module Circuit

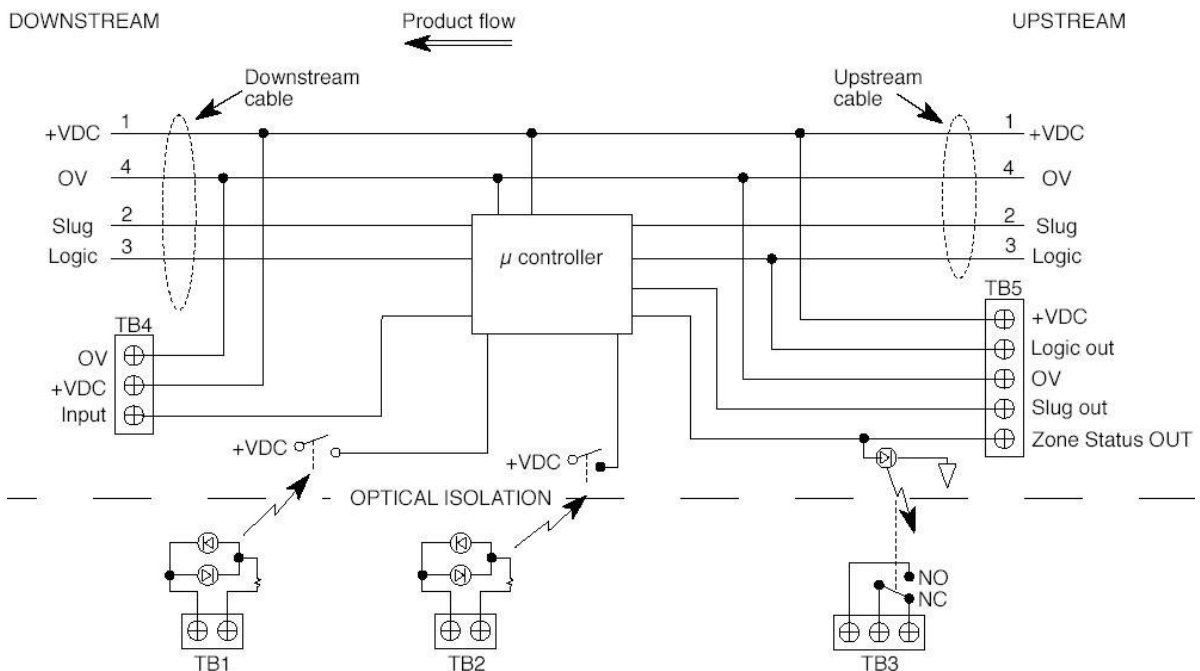

Figure 6: Release Function Board Layout

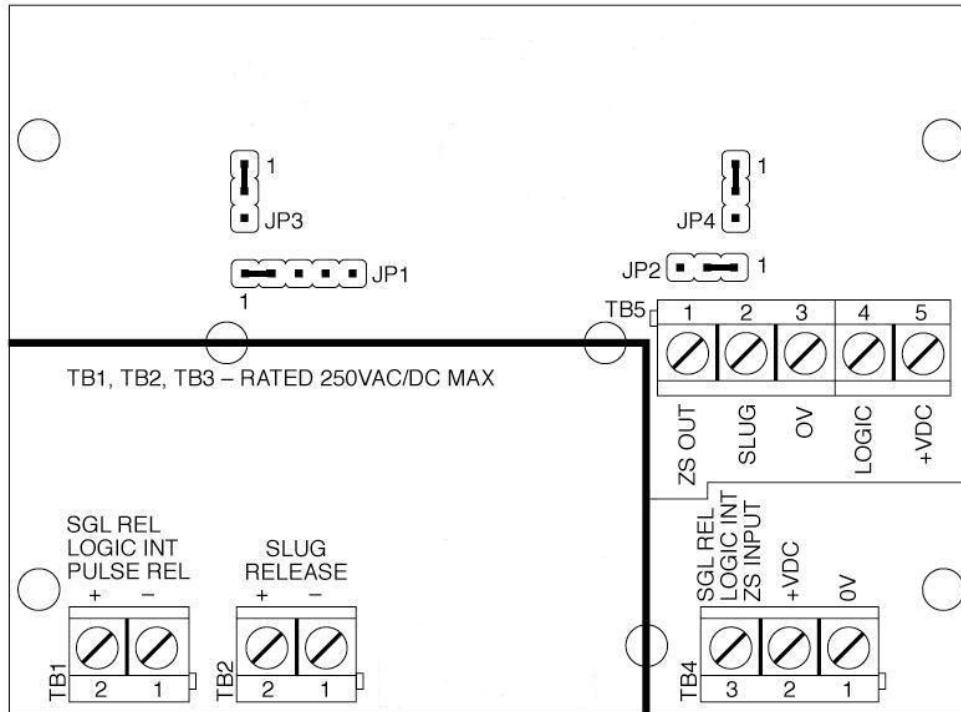
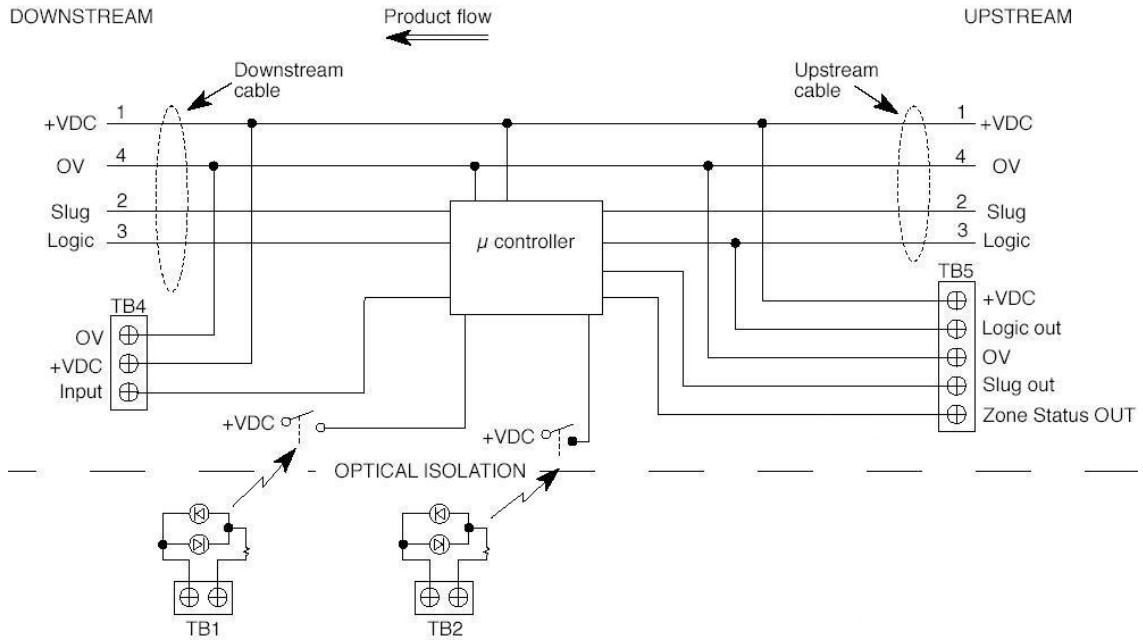

Figure 7: Release Function Module Circuit



5 POWER SUPPLIES

A 24VDC power supply is needed to power the logic assemblies and the function modules. One power T cable is prewired to the power supply. The power supply is available in 120VAC or 480VAC versions.

Power Supply Requirements

CRUZcontrol operates from a Class 2 power supply voltage of 24-28VDC. This limits the total number of CRUZcontrol Logic Assemblies that can be connected to one power supply. There is a limit on the maximum number of Logic Assemblies that can be in one continuous string, based on the cable length and power requirement of Logic Assemblies. More than one string of Logic Assemblies can be connected to a power supply, as long as the power supply output rating isn't exceeded.

The Function Modules require 10mA of current at 24 VDC. This needs to be considered, as it will reduce the total number of Logic Modules that can be connected to one Class 2 power supply to a quantity less than stated in table 5.

Table 5: Maximum Number of Logic Modules per String

Number of Zones	Zone Length	Number of Zones
End Tap (95W, 24VDC)	4 ft. zones	27
End Tap (95W, 28VDC)	4 ft. zones	35
Center Tap (95W, 24VDC)	4 ft. zones	54
Center Tap (95W, 28VDC)	4 ft. zones	46

5.1 POWER SUPPLY WIRING

Connection made between two Logic Assemblies using a T Cable

This drawing illustrates a power connection made between two intermediate accumulation zones making use of a T Cable. Note that all power and control signals, including the Slug and Logic Signals, pass through the T Cable uninterrupted.

Figure 8: Two Logic Assemblies using a T Cable

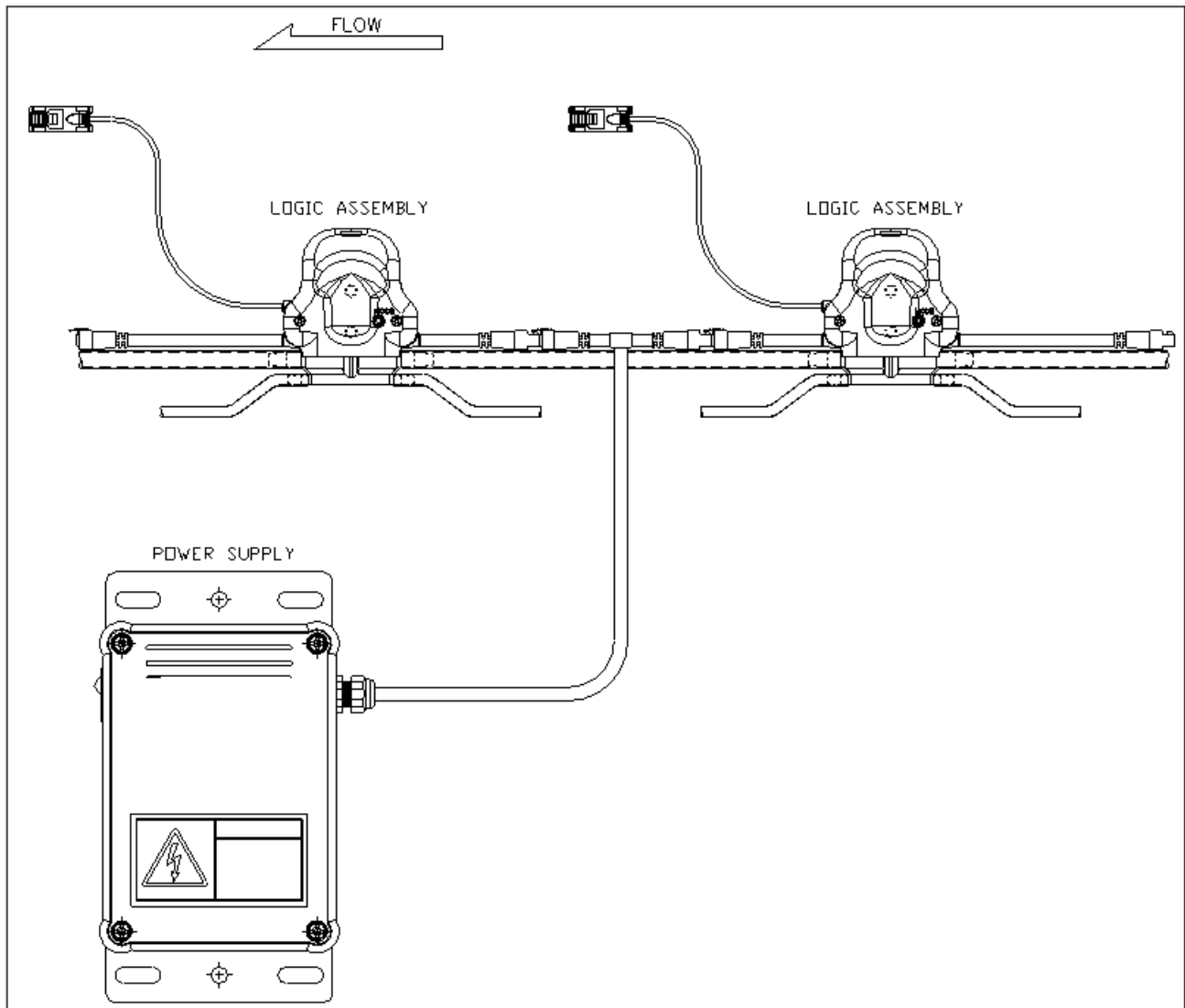

5.2 ONE POWER SUPPLY USED TO POWER TWO SEPARATE CRUZCONTROL SECTIONS

This drawing illustrates the use of one power supply to power two separate, short CRUZcontrol sections on two different conveyors. This can be done to make better use of the full capacity of a power supply.

It could be necessary to extend the T Cable leads to reach the power supply location. This should be done with a wire gauge large enough to prevent noticeable voltage drop. The number of CRUZcontrol zones that can be connected per string must also be reduced based on the voltage drop of the wire used.

The brown lead on the T Cable connects to +24 VDC on the power supply. The blue lead on the T Cable connects to 0 VDC on the power supply.

Figure 9: Two Separate CRUZcontrol Sections

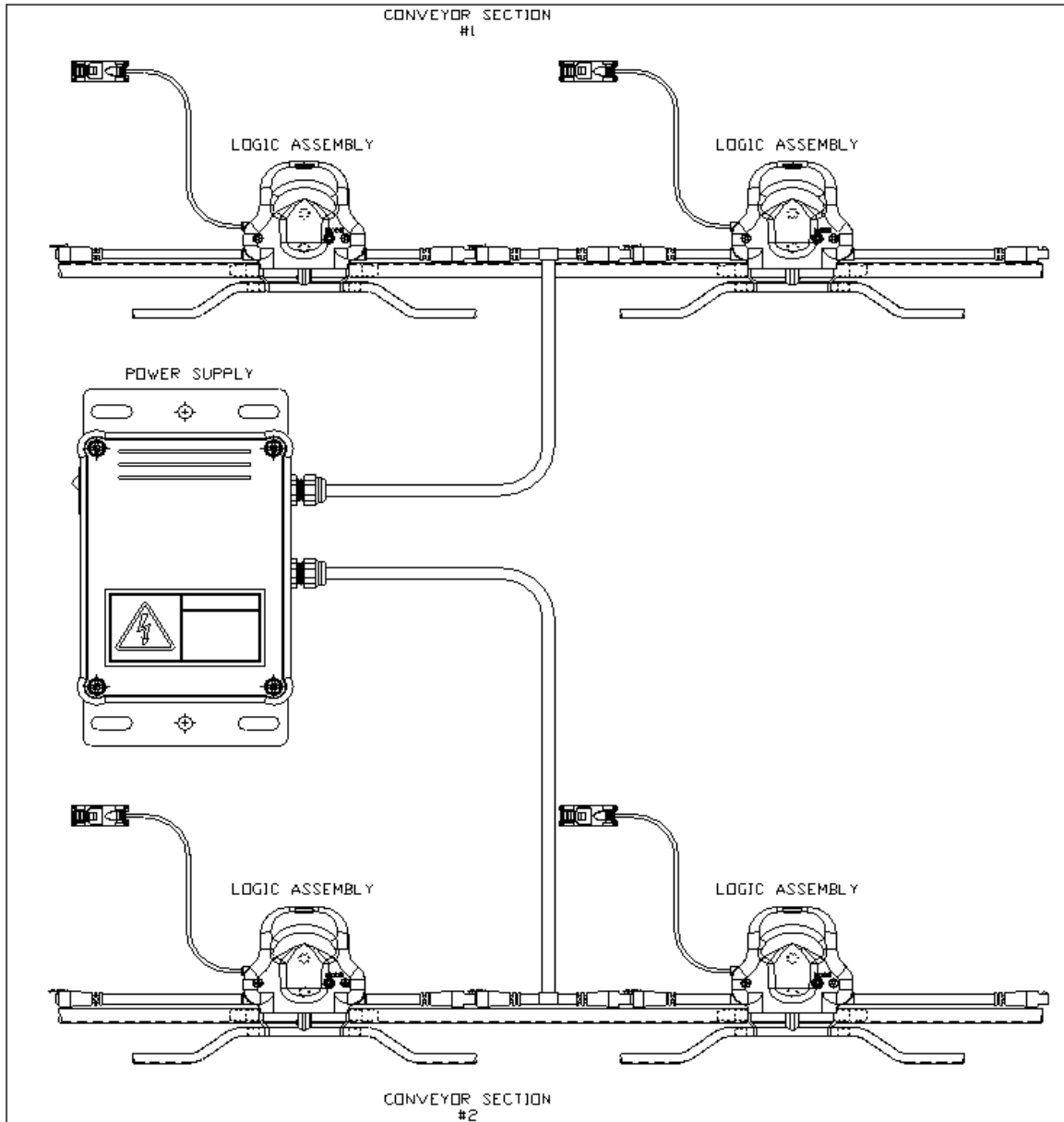

5.3 USING TWO POWER SUPPLIES TO POWER ONE EXTENDED CRUZCONTROL SECTION

A CRUZcontrol string with more than 54 Logic Assemblies would require the use of more than one power supply. This can be done, but it requires that the power supplies be isolated from each other at the +24 volt line. This drawing illustrates how to isolate the two strings making use of a Power Interrupt Cable. The + VDC line is not passed through, while the Slug Release and Singulation Release Signals as well as 0VDC are connected to pass the signals through uninterrupted.

Figure 10: One CRUZcontrol Section with Two Power Supplies

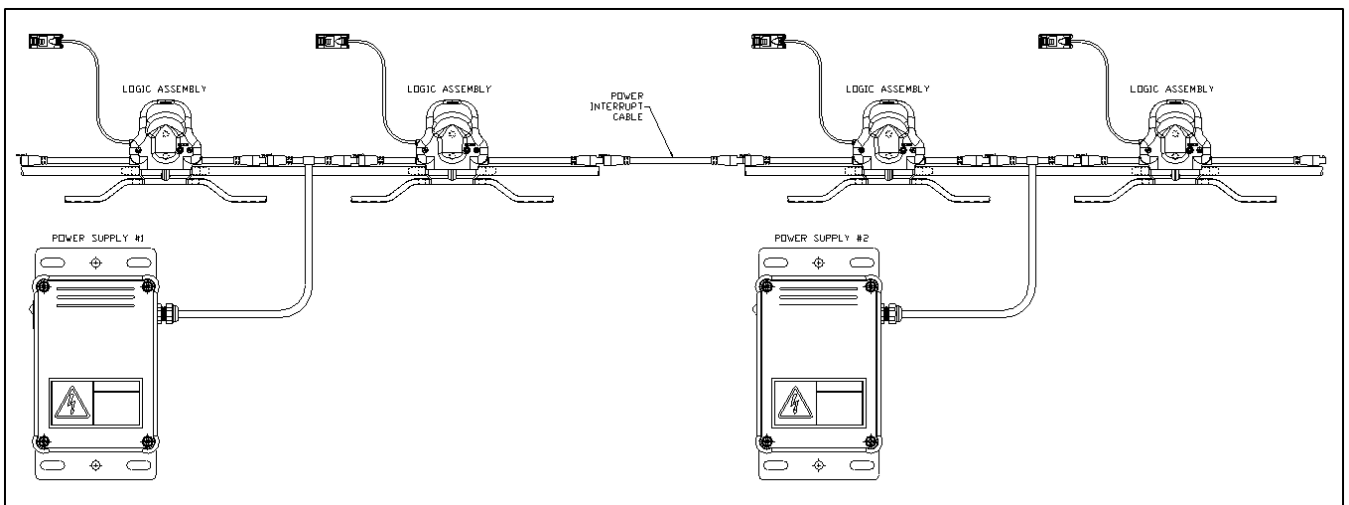

Power Supply Part Numbers

Table 6: Power Supply Part Numbers

Part Number		Description
Kit Part Number 1117431	1117972	PWS,24VDC,3.9A,120VAC, NBC CLASS 2, W/ 2X2 T-CABLE
	1117937	BRKT,POWER SUPPLY,NBC
	1117379	CABLE,CTRLS-T_CABLE-79"-2X2-FLYING LEADS
Kit Part Number 1117432	1107030	PWS,24VDC,3.8A,480VAC, NBC-,2 PH, CLASS 2, W/2X2 T-CABLE
	1117937	BRKT,POWER SUPPLY,NBC
	1117379	CABLE,CTRLS-T_CABLE-79"-2X2-FLYING LEADS
	1117380	CABLE,CTRLS-POWER INTRPT-2X2

Power Supply Assembly Reference (Field Assembly)

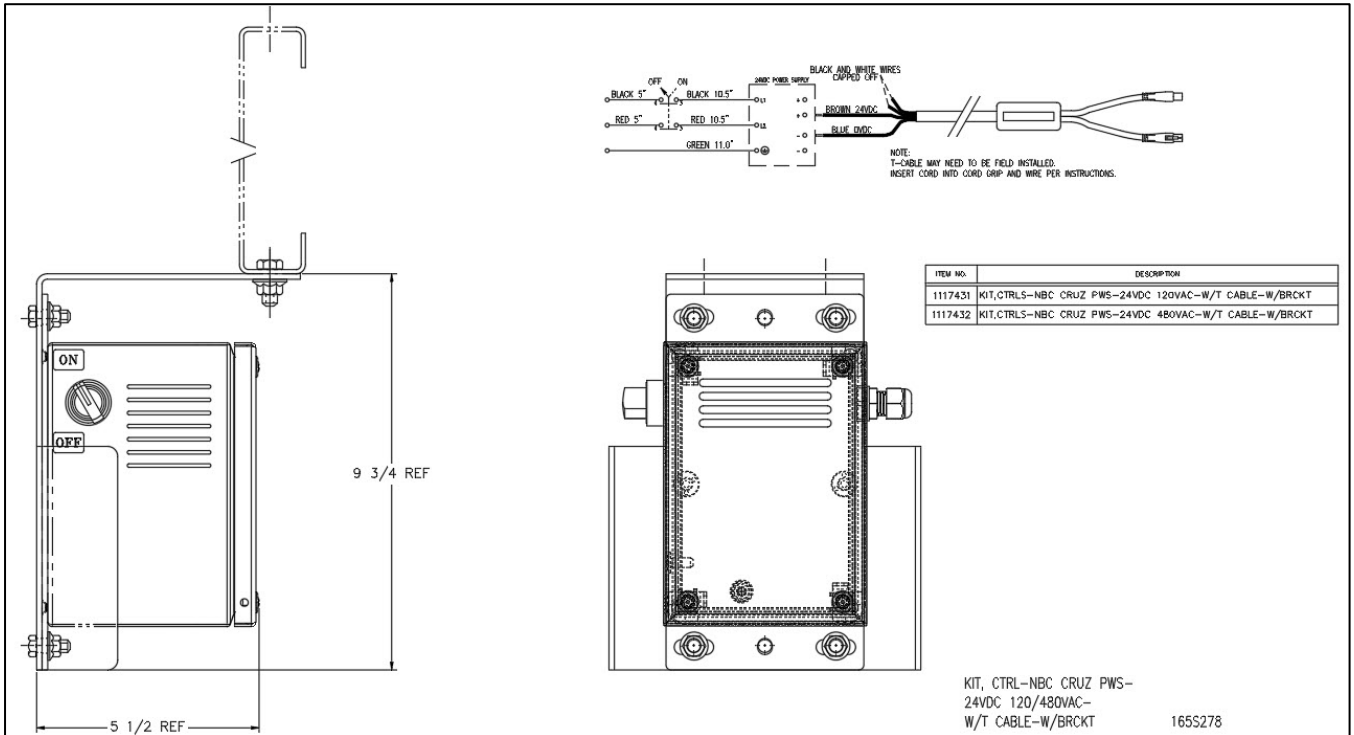

5.4 CRUZCONTROL TECHNICAL DATA

CRUZcontrol Power Supply Specification

Technical Data	PN 1117431	PN 1117432
Input Parameters		
Input Voltage Range V AC (nominal)	100... 120/220...240 V	380...480 V (2 phase)
Input Voltage Range V AC (continuous)	85...132/1184...264 V	323...552 V (2 phase)
Input Frequency	47...63 Hz	47...63 Hz
Phase	1	2
Input Voltage Range V DC (see derating requirements)	220... 375 V	consult factory
Input Rated Current	< 2.0 A (100 V AC)	< 0.42 A (400 V AC)
	< 0.95 A (196 V AC)	< 0.36 A (480 V AC)
Transient Immunity Over Entire Load Range		Consult factory
Output Parameters		
Output Voltage	24... 28 V DC	24... 28 V DC
Output Voltage Preset	24.5 V DC ±0.5%	24.5 V DC ± 0.5%
Ripple/Noise @ 20 MHz, 50 Ohm	< 50 m Vpp	< 50 m Vpp
Output Voltage Regulation Accuracy	0.5% Vout static	± 200 mV static
	±1.5% Vout dynamic	Dynamic not available
Output Rated Current	3.9 A (at 24 V)	3.75 A (at 24 V)
	3.2 A (at 28 V)	3.2 A (at 28 V)
Hold Up Time	> 20 ms (196 V AC, 24.5V/3.9 A)	Typ. 52 ms (at 400 V)
	> 20 ms (100 V AC, 24.5 V/3.9A)	Typ. 93 ms (at 480 V)
General Device Parameters		
Operating Temperature Range (Tamb) - Full Load	14... 140°F (-10... 60 C)	14... 140°F (-10... 60 C)
Operating Temperature Range (Tamb) - Derated	122... 140°F (50... 60 C)	122... 140°F (50... 60 C)
Storage Temperature	-13... 185°F (-25... 85 C)	-13... 185°F (-25... 85 C)
Humidity (Do not energize when condensation is present)	< 93%	< 95%
Input Cable Access	3/4 or 1/2 in. hole for conduit	
AC Connection Wires		
Stranded cable	0.3...2.5 mm ² / AWG 28-12	≥ 2,5 mm ² , AWG 26-12
Solid cable	0.3...4 mm ² / AWG 28-12	≥ 2,5 mm ² , AWG 26-12
Stripping at wire end	6 mm	6 mm
<i>Note: secure wires from strain</i>		
AC External Protection/Fusing	20A Max	30A Max
Output Connector Cables	M12 4-pin "T" cable	M12 4-pin "T" cable
Efficiency	90% (typical at 230 V AC, 3.9A)	89.5% (at 400 V)
		89.0% (at 480 V)
Protection Class - Type 1 Enclosure	IP 20 (DIN/IEC 60 529)	IP 20 (DIN/IEC 60 529)
MTBF	500,000 h @ 40C SN 29500	1.5 Mio h @ 40C SN 29500
	Not tested at MIL 217 GP40	482,000 h @ MIL 217 GP40
Dimensions	9.25 x 5.67 x 5.13	9.25 x 5.67 x 5.13
	(235 x 144 x 130.4 mm)	(235 x 144 x 130.4 mm)
Weight	3.9 lbs (1.8 kg)	4.4 lbs (2.0 kg)
Cover Screw Torque Rating (in-lb)	4±1	4±1
Mounting	Vertical mounting only. AC input enters from the bottom	
Clearance	Keep 4 in. clearance from ventilating slots in cover	
Applicable Standards		
EN 60 950-1, IEC 60 950	Yes	Yes
EN 60 204-1, EN 50 178	Yes	Yes
Third Party Approvals		
UL 508 Listing (US and Canada)	Multiple Listing	Multiple Listing
UL 60 950-1 Recognition (US and Canada)	Multiple Listing	Multiple Listing
NEC Class 2 According to UL 1310	Multiple Listing	Multiple Listing

5.5 ACCESSORIES

Auxiliary Photoelectric Sensor

There is often a need to sense product presence on a CRUZcontrol equipped conveyor, with the sensors connected to a control system other than CRUZcontrol. To allow for this, adequate space has been provided along side of the CRUZcontrol photoelectric sensors to allow for the mounting of a second independent photoelectric sensor, sharing the same holes through the conveyor side channels and the same reflector. Appropriate holes are provided for the photoelectric sensor mounting bracket. The discharge end of NBC conveyor is provided with an additional mounting location for a photoelectric sensor and reflector.

The following kits are available, which include the photoelectric sensor and appropriate bracket. Even though not normally needed, an extra reflector and adhesive mounting tape is also included with each kit.

The 10-30 VDC photo sensors are similar to the CRUZcontrol sensors. They are light operate, with a 50 mA maximum output current, and come with a 27 inch cable (no connector).

Table 7: Photoelectric sensor

Part Number	Description
1117727	Photoelectric sensor with bracket, 10-30 VDC PNP output

Reflector

Replacement reflectors can be ordered with the following part number.

Table 8: Reflector

Part Number	Description
400004	Reflector
1153640	Tape, foam double sided 3/4"square

Sensor Valve Assemblies

A Sensor Valve Assembly is used for applications not requiring accumulation logic, (controlling the zone with a PLC) but the solenoid valve and photoelectric sensor configuration as used in the CRUZcontrol channel is still desired.

Table 9: Sensor Valve Assembly

Part Number	Description
1116736	Sensor Valve Assembly

Extension Cables

The following extension cables are available to meet application requirements where longer zone lengths or skipped zones must be accommodated. Each cable has 4 conductors, with male and female 2X2 connector ends.

Table 10: Extension Cables

Part Number	Description
1117372	Extension Cable (39 inches)
1117373	Extension Cable (78 inches)
1117374	Extension Cable (156 inches)

Discharge Logic Control

Discharge Logic Control refers to using a standard Logic Assembly set to Basic Logic mode to control the release from the last discharge zone of a length of CRUZcontrol. This is typically done when CRUZcontrol conveyor (of any kind) feeds non-CRUZcontrol conveyor. There are no air connections made to the valve section of the Logic Assembly. When used this way, the added Logic Assembly is known as the Discharge Logic Assembly (DLA).

The Discharge Logic Assembly is mounted on the charge end of the conveyor immediately downstream of the last (discharge) zone of a length of CRUZcontrol accumulation conveyor. It is connected to the Logic Assembly of the discharge zone as shown. There is no need for a Function Module to be attached to it. The DLA does not need to be given a release signal. Product blocking that photoelectric sensor will stop release from the CRUZcontrol discharge zone, until the photoelectric sensor clears again. This operation can usually be left enabled and ready to function regardless of whether the receiving conveyor is running or off. There would be no need to interface the CRUZcontrol operation with the receiving conveyor operation, since the functioning of it is based solely on product movement.

Figure 11: Discharge Logic Control

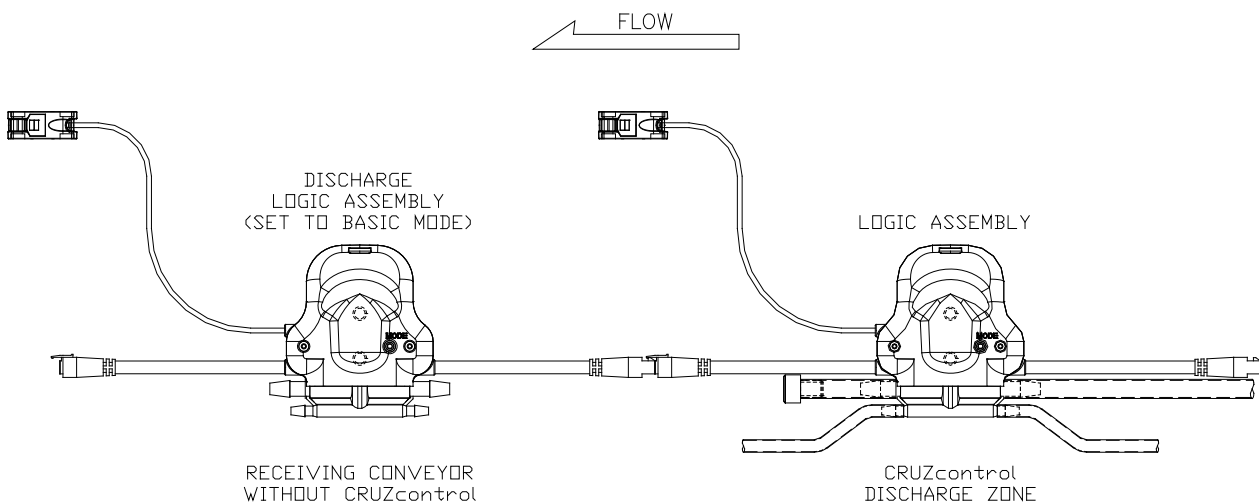

The following hardware listing is for two Discharge Logic Assembly kits consisting of the Discharge Logic Assembly, a reflector, and mounting brackets. The mounting brackets provide for the mounting of the Discharge Logic Assembly and reflector either ½ inch or 3 inches above a standard CRUZ side channel. Since every application is different, there will usually be a need to drill mounting holes for the brackets.

Table 11: Discharge Logic Assembly

Part Number	Description
1117859	Discharge Logic Assembly Kit, ½ inch above rollers scan height
1117860	Discharge Logic Assembly Kit, 3 inch above rollers scan height

6 CRUZCONTROL ON SITE INSTALLATION

6.1 PRE-INSTALLED ON THE CONVEYOR

- The CRUZcontrol Logic Assemblies are installed on the side channel of the conveyor bed.
- The air supply tubing for the conveyor is plumbed the length of the conveyor bed, passing through each Logic Assembly.
- The zone control air is plumbed from the Logic Assembly to the zone air pucks or cylinders.
- The photoelectric sensors are mounted for each zone, along with the reflector across the conveyor bed. The photoelectric sensors are tested to insure proper alignment with the reflectors, as well as proper functioning of the Logic Assemblies.

6.2 FIELD INSTALLATION

Bed to bed connections

- Connection of air supply tubing between conveyor beds, terminating the ends of the air supply tubing
- Connection of the Logic Assembly upstream or downstream cable from the last zone of a conveyor bed to the first zone in the next upstream conveyor bed

System connections

- Connecting the air supply to the conveyor
- Connecting a power supply into the string of Logic Assemblies
- Adding extension, power interrupt, or adapter cables if needed
- Adding auxiliary photoelectric sensors as required for lead zone and line full conditions
- Providing a release signal to the function module at the discharge zone

Figure 12: Logic Assembly

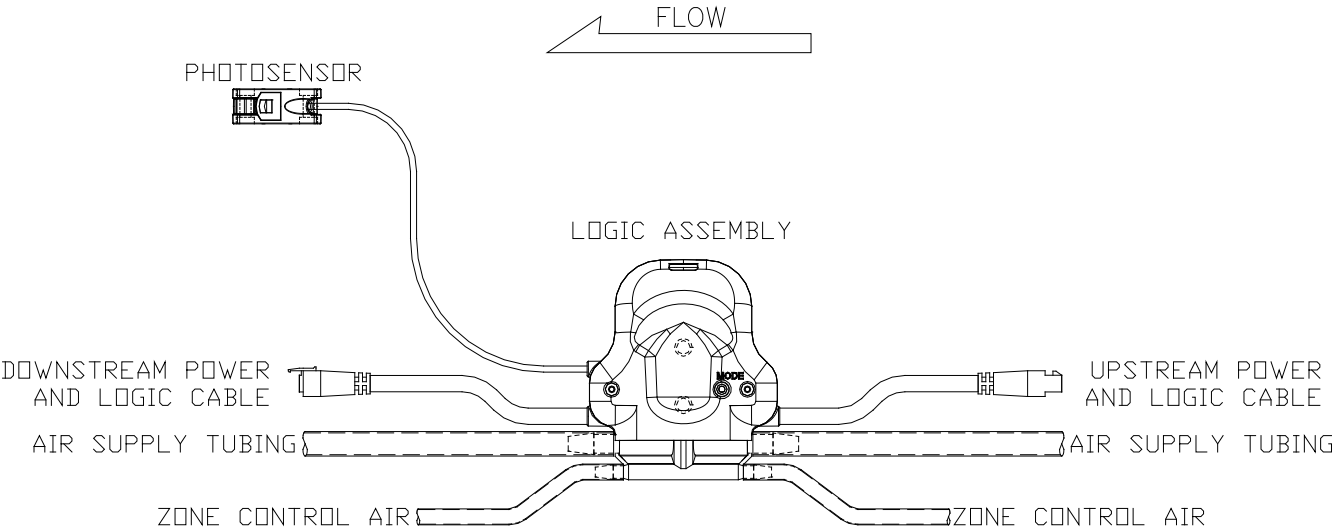

6.3 Conveyor Flow

The standard wiring is for left hand flow conveyors, for right hand flow conveyors the wiring direction will be reversed.

Figure 13: Left Hand Flow

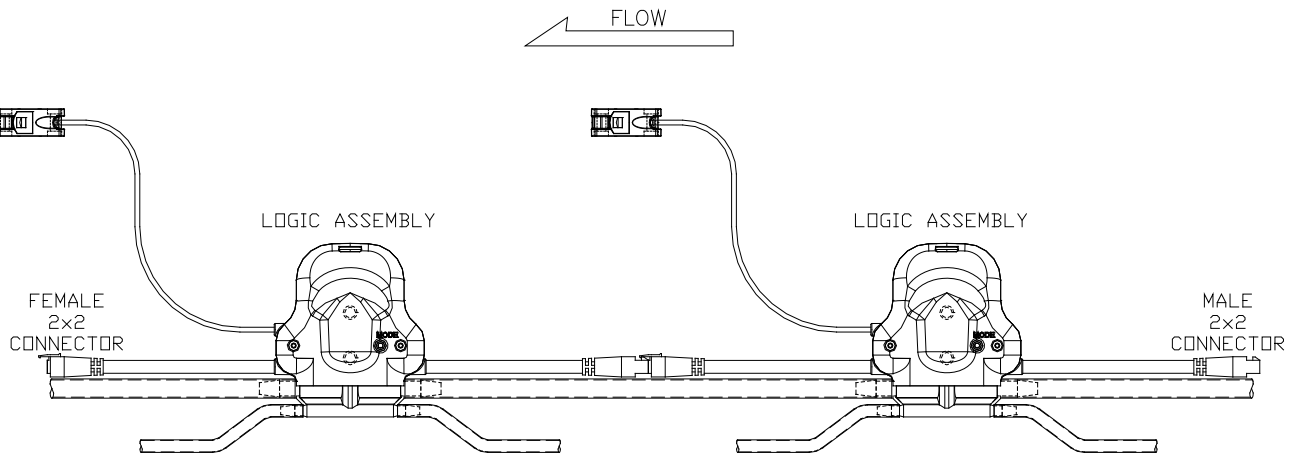
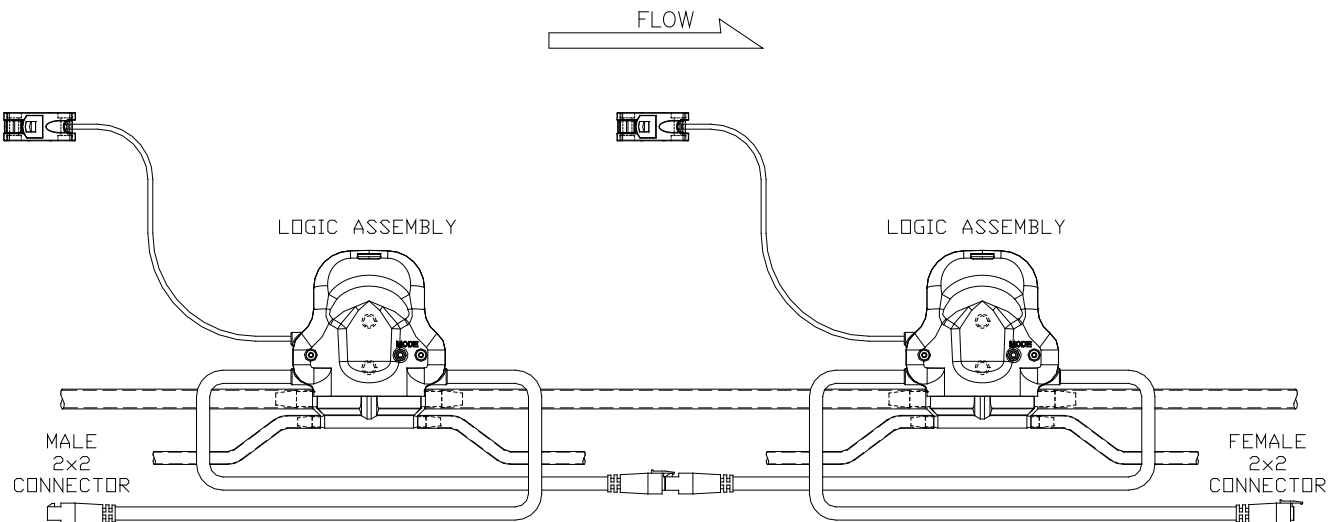

Figure 14: Right Hand Flow



6.3.1 EXAMPLES

This guideline provides various suggestions on how to apply CRUZcontrol to meet some specific control requirements.

Example 1: Applying Progressive CRUZcontrol

While this example is based specifically on contact accumulation NBC-C, the principals covered also apply to non-contact accumulation conveyor NBC-N.

CRUZcontrol Logic Assemblies are designed to be fail-safe. A loss of module power, a disconnected or severed cable, or a dirty or failed photoelectric sensor will all result in the stopping of a zone, initiating accumulation beginning from the affected zone.

With Progressive Logic mode, failure of a Logic Assembly to function properly could possibly result in product accumulating with zones not stopping as required. While this should be unlikely due to the fail-safe nature of the Logic Assembly, the effects of such a failure should be considered. This type of failure could result in excessive line pressure, eventually causing product to push through the discharge zone of the conveyor. Jam detection sensors should be used as appropriate to minimize the effects of such a failure.

A product jam on the conveyor, stopping the free flow of product, could also create a situation where Progressive Logic mode CRUZcontrol can't function properly due to product not blocking one or more of the photoelectric sensors. This would probably be the most common cause of excessive line pressure resulting from the use of Progressive Logic mode CRUZcontrol.

A solution to this problem is to provide one Basic Logic mode zone at the discharge end of every 12-foot bed of conveyor. This would limit the length of conveyor that could possibly be driving product against a jam point to 12 feet.

The use of one Basic Logic mode zone on every 12-foot bed will disrupt the flow of product to some degree, but with adequate speed and product weight the flowing product should coast through the basic zones without any noticeable effect on the throughput rate. One exception is at the charge and discharge ends of a length of NBC-C accumulation conveyor, where the effects of using Basic Logic mode on the throughput rate needs to be considered. If there is a need to maximize throughput rates, the use of all Progressive Logic mode zones should be retained in those locations.

CRUZcontrol does provide an option for slug release. Both the Basic and Progressive Logic modes of accumulation will release at the maximum possible discharge rate when slug release is enabled. It will also create a situation where a product jam could result in excessive line pressure buildup. If the slug release feature is used, it should be used with caution, and for a limited number of successive accumulation zones.

Example 2: Progressive Logic Accumulation Release Control

CRUZcontrol Logic Assemblies set to Progressive Logic mode provide for high throughput rates and efficient release, compared to Basic Logic mode. In simple terms, Basic Logic tries to create zone length gaps in the flow of product, where as Progressive Logic allows product to flow without creating gaps.

The product throughput rate for Progressive Logic, measured in case-feet per minute, can equal the conveyor speed. This can create problems. If, for example, an NBC-C conveyor running at 180 feet per minute is feeding product to an induction belt conveyor running at 100 feet per minute, the belt conveyor will be overrun, meaning that excessive line pressure will build up at the discharge end of the NBC-C.

There are several possible solutions to handle this situation:

1. The speed of the accumulation conveyor could be set at less than the speed of the next conveyor down-stream. In the example mentioned, if the NBC-C were running at 100 feet per minute, there wouldn't be an issue. This is not often possible. If the accumulation conveyor needed to receive product at a higher input rate, the speed would have to be higher. If densely packed accumulation were desired, that would also require the speed to be above 100 feet per minute.
2. The release of product from the accumulation conveyor could be logically controlled so as to limit the release rate. If the NBC-C running at 180 feet per minute were to be given a Singulation Release signal for 3.3 seconds, and then kept off for 2.7 seconds, with that sequence repeating, the theoretical release rate should be close to 100 product-feet per minute ($180 \text{ fpm} \times 3.3 \text{ sec.} / (3.3 \text{ sec.} + 2.7 \text{ sec.})$). The actual release rate could be more, with product coast and shorter than zone length product lengths allowing more product than expected to progress past the release point. Assuming that the release signal is PLC controlled, an advantage to this approach is that the release sequence timing could be easily altered to increase or decrease the release rate.

The CRUZcontrol Logic Assembly at the final discharge zone could be set to Basic Logic mode, with all other upstream Logic Assemblies set to Progressive Logic mode. This would reduce the NBC-C release rate while still retaining the infeed and throughput rate benefits of Progressive Logic mode. The release rate would be a function of the speed of the accumulation conveyor, the speed of the receiving conveyor, and also the size and weight characteristics of the conveyed product. If the NBC-C running at 180 feet per minute had a Logic Assembly set to Basic Logic mode at only the discharge end, the release rate would be closer to the 100 product feet per minute capacity of the downstream induction belt conveyor.

Example 3: Releasing from CRUZcontrol

Releasing from CRUZcontrol	
Problem	Releasing Accumulated Product
Solution	When using CRUZcontrol the product will automatically accumulate. A signal must be given to the function module to get it to release.
Configuration	Plug Function module into discharge zone. All jumpers are set to pins 1-2. Give function module a release signal either through the isolated input as shown in Figure 15 or through the non-isolated inputs as shown in Figure 16.
Operation	Product will release for as long as the release signal is given.

Figure 15: Isolated Input Single Release

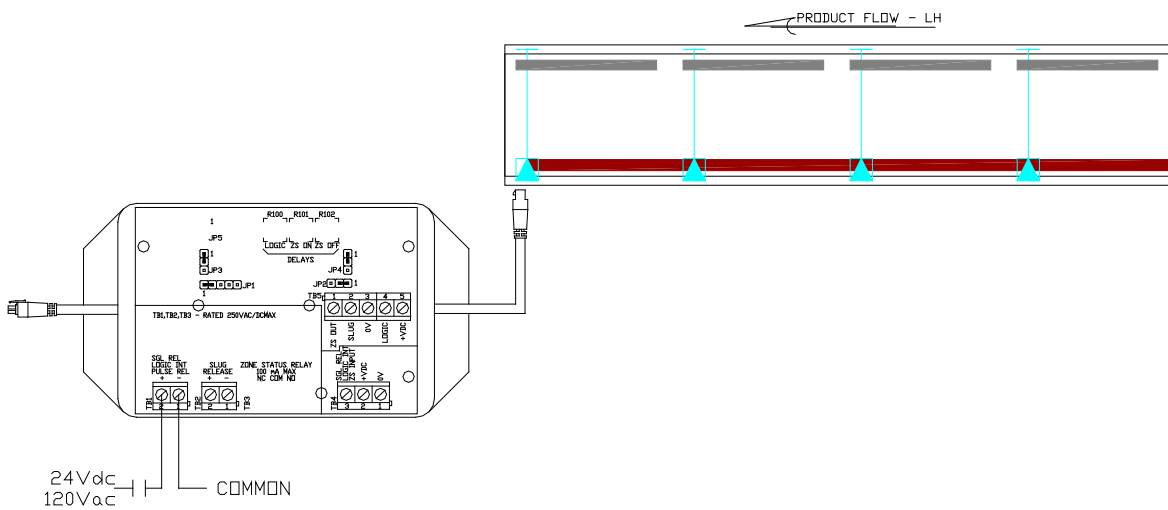
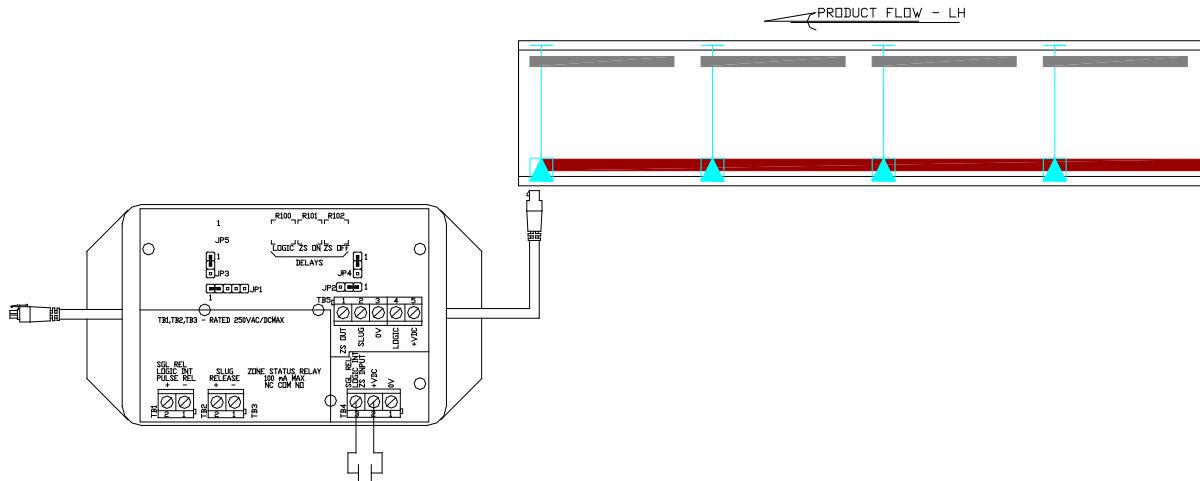

Figure 16: Non-Isolated Input Single Release



Example 4: CRUZcontrol around a curve. (Low rate)

CRUZcontrol around a curve – Low Rate	
Problem	Product releasing into a curve then not having a zone to occupy. This situation occurs because it takes longer for product to go from zone 2 to zone 1 than it does for product to go from zone 3 to zone 2.
Solution	Delay zone 3 releasing until product has reached zone 1 This example will only work if the throughput rate is low.
Configuration	Set CRUZcontrol Logic Assemblies to Basic Logic mode. Plug full function module between zones 2 and 3. Set the logic delay R100 potentiometer to delay the release signal from zone 2 to 3 until product has reached zone 1.
Operation	Carton flow from zone 3, to zone 2, to zone 1, occurs as normal. When a carton first clears the zone 2 photoelectric sensor, the release of the next carton from zone 3 is inhibited by the setting of the logic delay relay in the full function module. No external logic signals are require. The release will need to be delayed until the carton released from zone 2 reaches zone 1.

The release delay is not retained in the event of a system shut down. If a carton is flowing around the curve and the system is shut down, upon start up a second carton could be released from Zone 2 to the curve before the first carton has had the chance to clear the curve. In that event, manual intervention might be required to clear the curve of the extra carton.

Figure 17: CRUZcontrol around a curve (low rate)

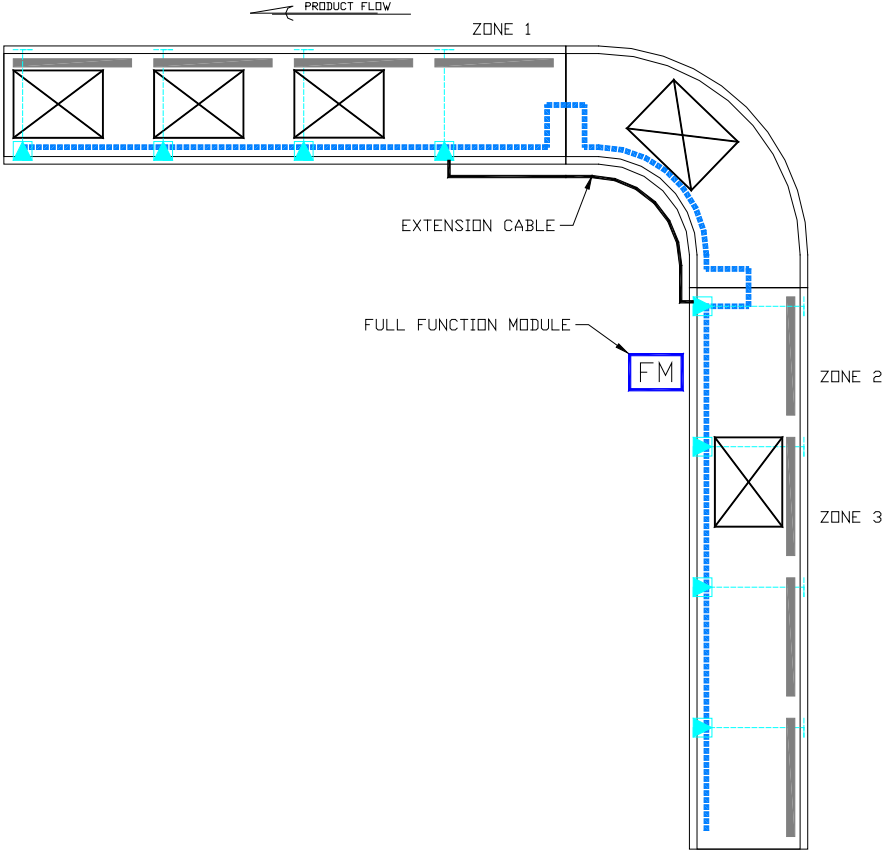

Example 5: CRUZcontrol around a curve. (High rate)

CRUZcontrol around a curve – High Rate	
Problem	<p>Product releasing into a curve then not having a zone to occupy.</p> <p>This situation occurs because it takes longer for product to go from zone 5 to zone 4 than it does for product to go from zone 6 to zone 5.</p>
Solution	<p>Stop zone 5 releasing if line full photoelectric sensor is block for a predetermined time period or if logic assembly in zone 4 is blocked due to accumulation.</p>
Configuration	<p>Plug full function module between zones 4 and 5.</p> <p>Jumper JP3, 2-3 (logic interrupt)</p> <p>Jumper JP4 not connected (zone status)</p> <p>Set ZS on (R101) and ZS off (R102) potentiometers. Range is from 0-20seconds. A normal operating range would be about 3 seconds each depending on the speed of the conveyor.</p> <p>Wire photoelectric sensor to TB4.</p> <ul style="list-style-type: none"> Blue wire TB4, 1 (0VDC) Brown wire TB4, 2 (+VDC) Black wire TB4, 3 (ZS INPUT) <p>Wire function module for time delay.</p> <ul style="list-style-type: none"> TB4, 1 (0VDC) to TB1, 1 (-) TB4, 2 (+VDC) to TB3, 2 (COM) TB3, 1 (NO) to TB1, 2 (+)
Operation	<p>The Full Function Module is connected as shown just downstream of the last accumulation zone prior to the curve. Release from that zone is stopped if the Auxiliary Photo Sensor senses full accumulation (blocked for a time delay period), or if the Logic Assembly just downstream of the curve stops the upstream release due to being accumulated.</p> <p>If the Logic Assembly just downstream of the curve is set to Basic Logic mode, the release rate into the curve would be affected. The use of Progressive Logic mode after the curve would allow for higher rates.</p> <p>Note that stopping the release of product as done in this example could result in a product left partially on the powered curve with the trailing end on the stopped discharge end of the accumulation conveyor. If this is a concern, a photo sensor should be added to the discharge zone, with appropriate logic to insure that no products are stopped partially released. This could require the addition of PLC based logic.</p>

Figure 18: CRUZcontrol around a curve. (High rate)

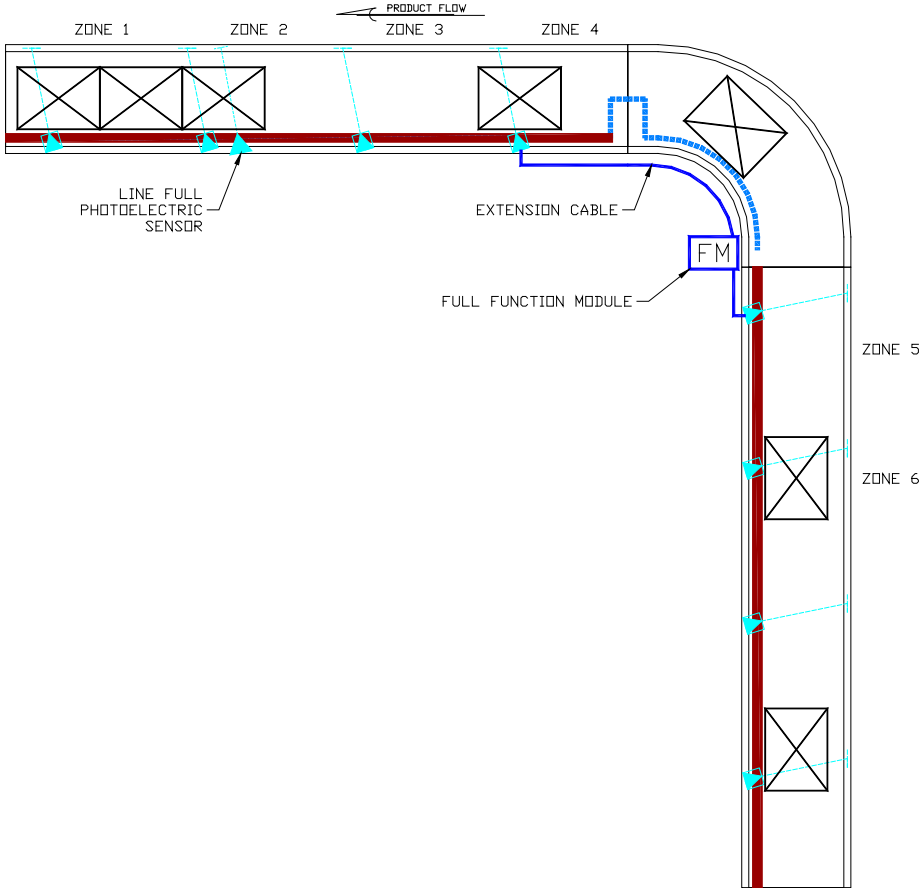
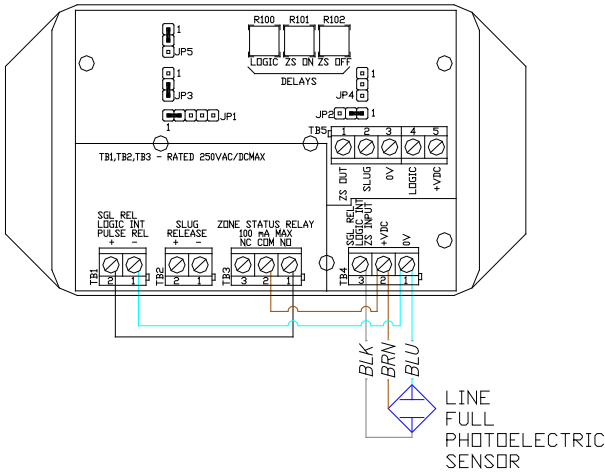

Figure 19: Function Module Wiring



Example 6: Creating a work zone

Creating a work zone	
Problem	Creating a work zone in the middle of a section of CRUZcontrol
Solution	Use the release function module and interrupt the downstream logic to start accumulation.
Configuration	When using TB1 to interrupt the logic set jumper terminal JP3, 2-3 When using TB4 to interrupt the logic set jumper terminal JP4, 2-3
User Action:	Apply a high signal to TB1 (24Vdc/120Vac) or TB4 (24Vdc)
Operation	All product stops at a specific accumulation zone, when the contact is closed and is released when the contact is opened.

Figure 20: Work Zone

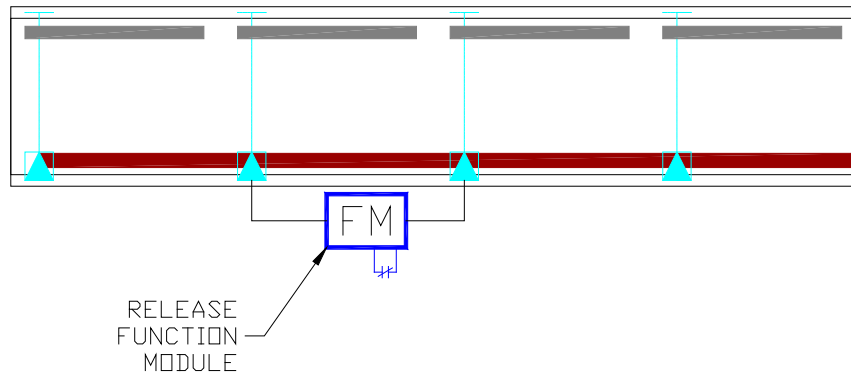

Figure 21: Work Zone Using TB1

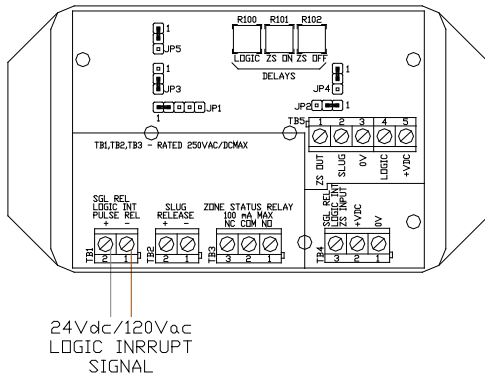
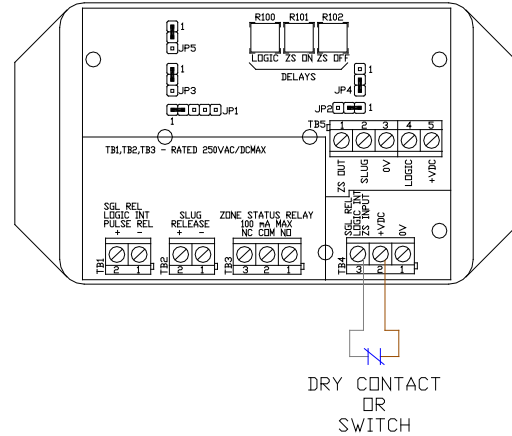

Figure 22: Work Zone Using TB4



Example 7: NBC-C accumulation release to NBC-N conveyer

NBC-C accumulation release to NBC-N conveyer	
Problem	Creating line pressure when feeding a slower conveyer
Solution	Use logic assembly as a discharge logic assembly
Configuration	Place Discharge Logic Assembly (DLA) downstream of conveyer discharge zone. Set mode to basic. Do not plumb air line to logic assembly.
User Action:	None needed.
Operation	The Discharge Logic Assembly is connected to the Logic Assembly at the discharge end of the NBC-C conveyer. There is no need for a Function Module to be attached to it. The DLA does not need to be given a release signal. Product blocking that photoelectric sensor will stop release from the NBC-C discharge zone, until the photoelectric sensor clears again. This operation is left enabled and ready to function regardless of whether the induction conveyer is running or off. There is no need to interface the CRUZcontrol operation with the induction conveyer operation, since the functioning of it is based solely on product movement.

NBC-C conveyer, when accumulating and subsequently releasing accumulated product, will result in some amount of line pressure at the discharge end of the conveyer. This is caused by the momentum of moving product coasting to a stop as it accumulates.

Example:

The NBC-C is running at 180 feet per minute, feeding the induction conveyer section prior to a pick zone module diverter. Without proper control of the discharge from the NBC-C, cartons released to

the induction conveyor could possibly overdrive it and push past the 90 fpm section onto the 180 fpm section, not permitting product gapping to occur as required for the diverter to function properly.

The mounting location of the Discharge Logic Assembly photoelectric sensor and the reflector will determine release performance. A good starting point would be to locate the photoelectric sensor 12 inches downstream from the charge end of the induction conveyor, and the reflector 18 inches downstream from the charge end. The final locations should be determined based on system performance.

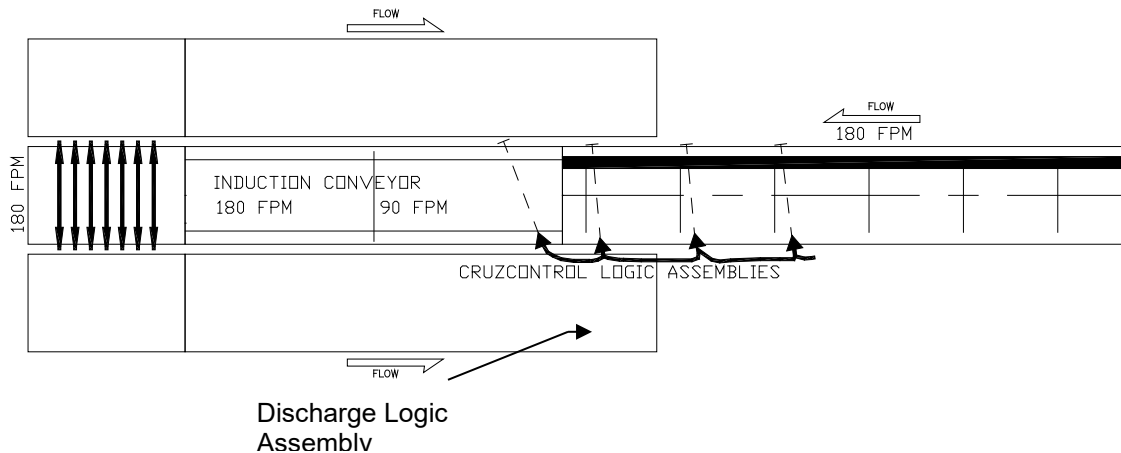

6.4 EXAMPLE 8: PRODUCT GAPPING

The following describes a technique, using CRUZcontrol, which creates a gap in a train of moving product. In the situation described, the gap is used to allow for the raising of a product stop. This would apply primarily to the progressive mode of accumulation control, which accumulates and discharges from accumulation with only very minimal gaps between products.

The following illustrates an NBC-C accumulation lane used to release product to a merge conveyor. A Product Stop is located at the end of the accumulation lane, controlled by the solenoid valve as shown. The last two accumulation zones are also provided with brakes, as shown. These brakes are controlled by the CRUZcontrol Logic Assemblies that also control the zone drive. Also shown just prior to the Product Stop is a Product Present Photosensor.

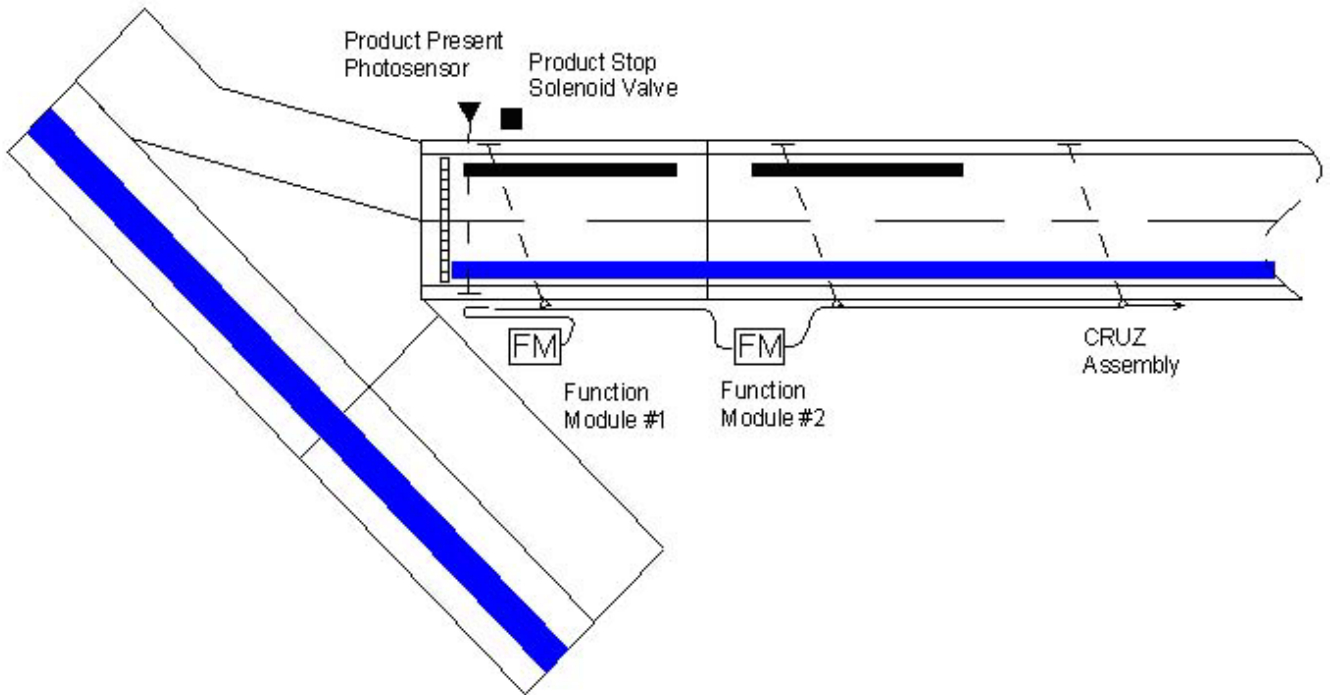

6.5 OPERATION

The Product Present Photosensor is connected to a PLC (programmable logic controller). The Photosensor is used to sense if product is accumulated behind the Product Stop, ready to be released. The Photosensor is also used to sense a gap in the flow of product adequate enough to raise the Product Stop after releasing product from the lane.

The Product Stop is solenoid activated, and controlled by the PLC. The stop is lowered by energizing the solenoid.

Function Module #1 (a Release Function Module) is configured and wired for Singulation Release operation. (Refer to the CRUZcontrol Installation, Operation, and Maintenance Manual for additional Function Module information). The signal provided to the Product Stop solenoid is also connected to Function Module #1.

When the Product Stop is raised (solenoid and Function Module not energized), product blocking the Photosensor of the CRUZcontrol Logic Assembly will result in the conveyor zone going into accumulation and the zone brake being activated. This in turn enables accumulation beginning with the next upstream accumulation zone, once the photosensor in that zone is blocked.

Function Module #2 (also a Release Function Module) is configured and wired for Logic Interrupt operation. When it receives a signal (from the PLC), it passes the logic signal from the downstream accumulation zone to the upstream accumulation zone. Accumulation and release function normally, as if there no Function Module installed.

To create a gap in the flow of product, the PLC signal to Function Module #2 is turned off. This puts the zone upstream of Function Module #2 into accumulation mode, once its Photosensor is blocked. The brake in the zone is also set whenever the zone is set to accumulate.

Logic Assembly Specifications

Logic Assembly

Figure - Logic Module

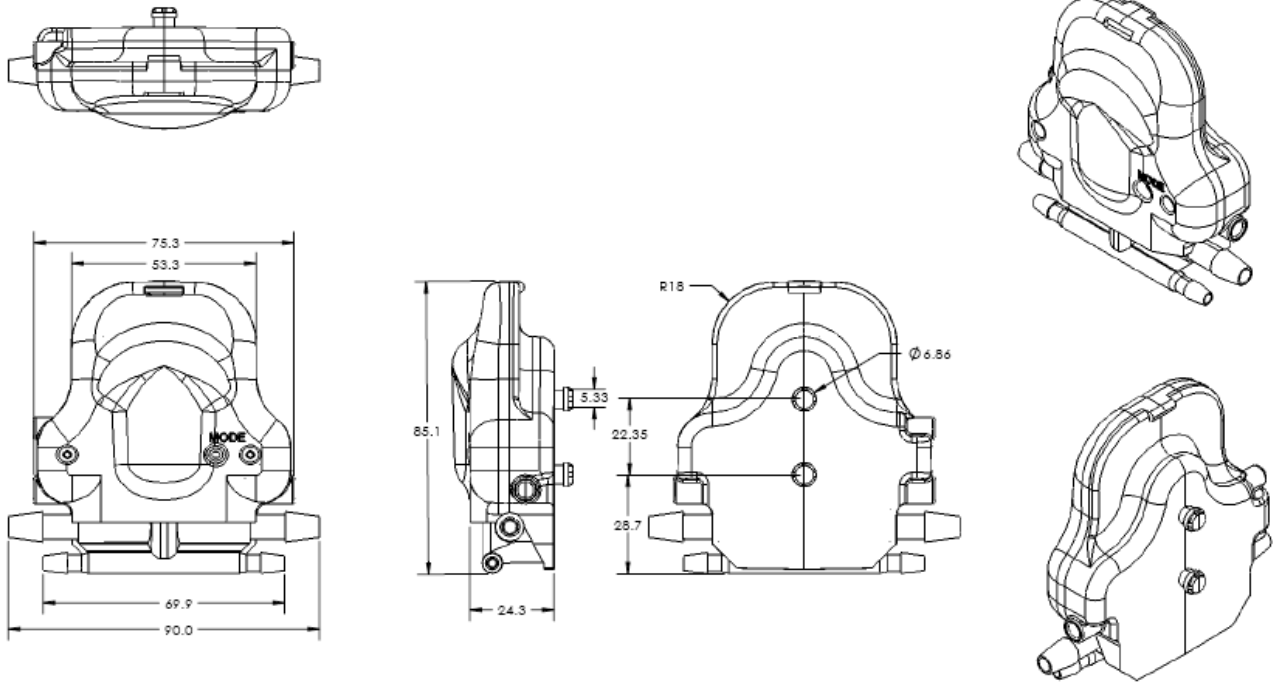

Table - Logic Module Mechanical Specification

Maximum Height	3.35 in. (85.1 mm)
Maximum Width	2.5 in. (63.5 mm)
Maximum Depth	1.25 in. (32 mm)
Daisy Chain Cable Length	Downstream - 28 in. (711 mm), Upstream - 28 in. (711 mm) ±1 in.
Daisy Chain Wire Gauge	22 AWG
Daisy Chain Connection Type	Overmolded 2x2; Downstream - Female, Upstream - Male
Sensor Cable Length	28 in. (711mm) ±1 in.
Input Air Connection	Barbed tube fitting for 3/8 in. O.D., 1/4 in. I.D. tubing
Output Air Connection	Barbed tube fitting for 1/4 in. O.D., 0.160 in. I.D. tubing
Enclosure Rating	IP20
Housing Material	ABS plastic

Color	Back cover and manifold - Black; Front cover - PMS 420
Mounting	Twin Keyhole (same as current module)
Ambient Temperature – Operating	+14...122°F (-10...+50C)
Ambient Temperature – Storage	-40...158°F (-40...+70C)

Table - Logic Module Electrical Specification

Supply Voltage	24 VDC (-20%/+15%)
Voltage Drop per Module	TBD
Current Consumption	TBD
Maximum Logic Output Current	100 mA
Response Time	<2.5 ms
Switching Frequency	200 Hz
Maximum # of Logic Modules per String	End Tap (95W, 24Vs) - 4 ft. zones = 25 End Tap (95W, 28Vs) - 4 ft. zones = 33 Center Tap (95W, 24Vs) - 4 ft. zones = 50 Center Tap (95W, 28Vs) - 4 ft. zones = 46
Approvals	CE, UL Listed, NFPA 70, NEC

Figure - Sensor

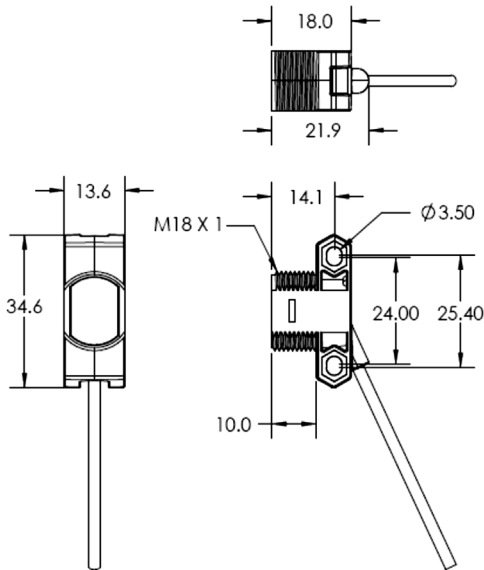

Table - Sensor Optical Specification

Sensor Model	ZL2-P2400S04
Sensor Part Number	2048176
Sensor Type	Reflex, Polarized
Switching Logic	Light operate
Light Source	Red LED
Output Indicator	Amber
Power Indicator	Green
Life Expectancy	100,000 hours @ 77°F (25C)
Light Spot Diameter	4.9 in. x 4.9 in. at 39.4 in. (125mm x 125mm at 1000mm)
Housing Material	ABS
Enclosure Rating	IP67

Table - Sensor Electrical Specification

Supply Voltage	10...30 VDC
Ripple	<5 Vss
Current Consumption	<20 mA (without load)
Output Current Max.	50 mA
Response Time	<1.25 ms
Switching Frequency	400 Hz
Cable Length	28 in. (711mm), ±1 in.
Connection to Logic Module	Hard-wire on the Downstream side
Ambient Temperature – Operating	-13...122°F (-25...+50C)
Ambient Temperature – Storage	-40...158°F (-40...+70C)

Table - Pneumatic Valve Specification

Operating Pressure Range	0-40 psi (0-2.75 bar)
Flow rate Capacity	≥ 0.04 Cv (40 NI/m)
Ventilation Capacity	≥ 0.04 Cv (40 NI/m)
Power Consumption	1W
Minimum Supply Voltage	19.2 VDC
Maximum Supply Voltage	28.8 VDC
Duty Cycle	100%
Life Expectancy	100 million cycles
Input Air Connection	3/8 in. (9.5mm) barbed fitting
Output Air Connection	1/4 in. (6mm) barbed fitting
Operating Mode2	N.O. (Air to Brake)
Air supply	Non-lubricated, 5 micron or less

Figure – Logic Module Wiring

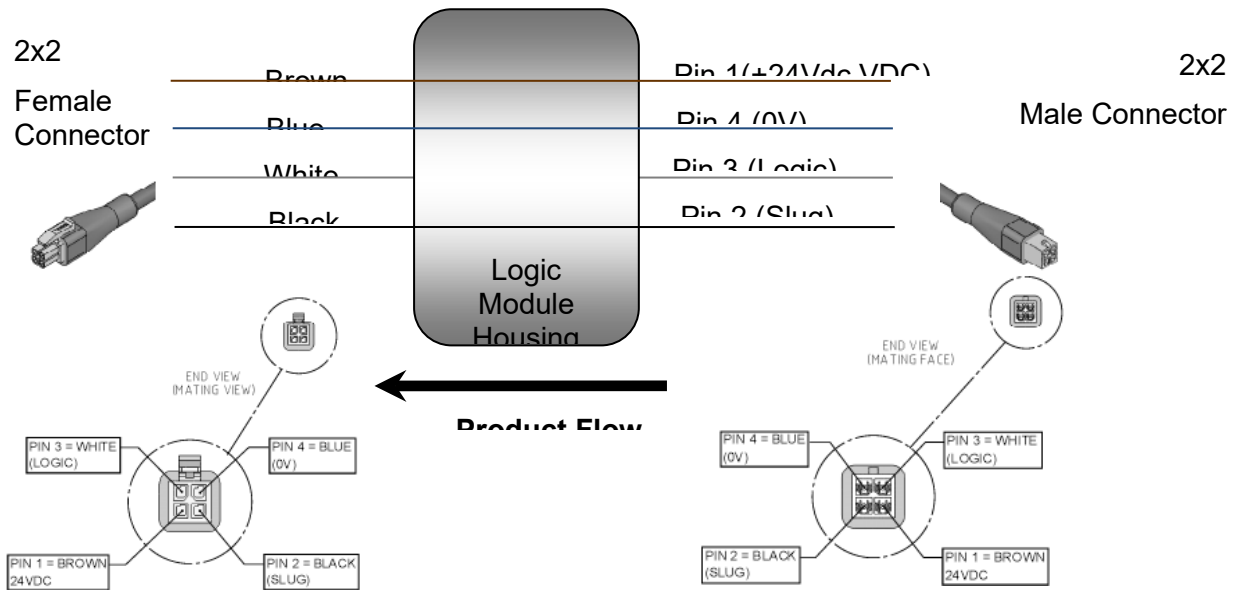

Function Module Specifications

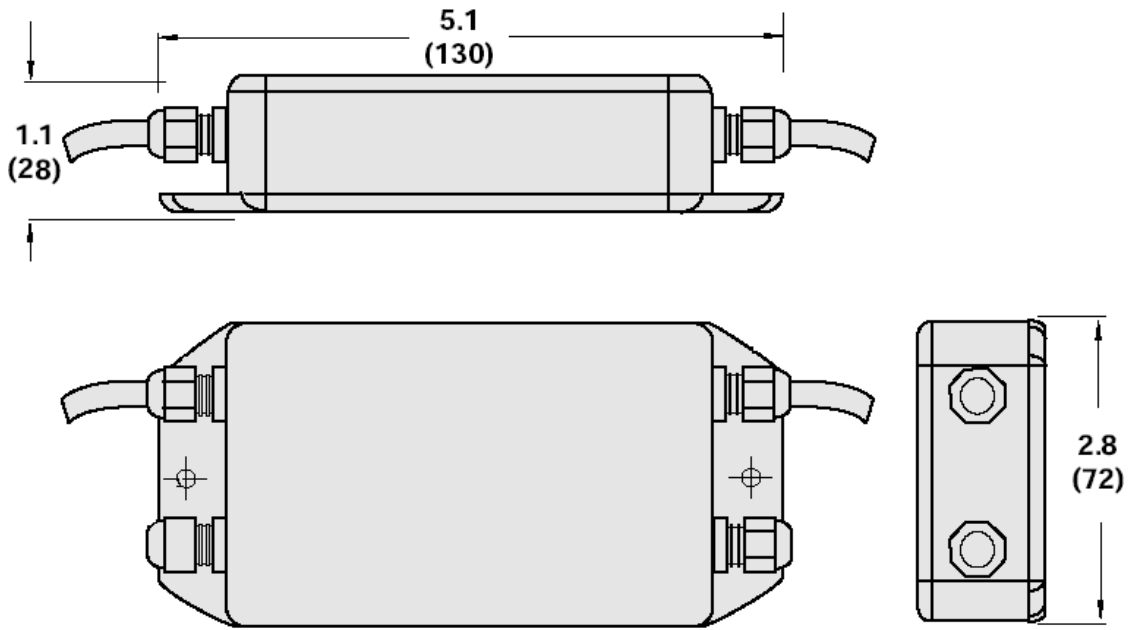

6.6 FUNCTION MODULE TECHNICAL DATA

Table – Full Function Module Specification

Technical Data	
Interface to CRUZcontrol	
Upstream connection	Male, 2X2, 4-PIN, 300 mm cable
Downstream connection	Female, 2X2, 4-PIN, 300 mm cable
Power	
Supply voltage from daisy chain	18...30 VDC
Power consumption of ZIM	10 mA, no load
ZoneControl system power TB4 input	24...28 VDC typical. Limit values: 18...30 VDC
Input ratings	
TB4 Power inputs +VDC, Common	24 VDC typical, 30 VDC max.
TB4 Release/Interrupt input	18...30 VDC
	Guaranteed OFF Voltage: <= 4.0 VDC
	Guaranteed ON Voltage: >= 15.0 VDC
	Typical ON state current draw @24V: 4mA
TB1 Single Release/Logic Interrupt/Pulse Release input ¹	18...250 UC ¹
	Guaranteed OFF Voltage: <= 4 UC
	Guaranteed ON Voltage: >= 15.0 VDC
	Typical ON state current draw 2.5 mA
TB2 Slug Release input ¹	18...250 UC ¹
	Guaranteed OFF Voltage: <= 4 UC
	Guaranteed ON Voltage: >= 15.0 VDC
	Typical ON state current draw 2.5 mA
Output ratings	
TB5 Logic output	PNP; 2.21 kohm impedance typical
TB5 Zone Status output	PNP; 2.21 kohm impedance typical
TB3 Zone Status Relay ²	250 UC max ; 100 mA max. Resistive load ²
Physical properties	
Terminal block	
Terminal block wire	30 to 12 AWG (2.5 ... 0.2mm ² , strip length ¼" (6.0 mm))
Screw terminal torque	5 in-lbs. (0.56 Nm)
Potentiometers	
Mechanical angle	270° nominal
Stop strength	7.0 oz-in minimum
Housing	
Dimensions	5.125" x 3.75" x 1.125" (130mm x 95mm x 29mm)
Mounting	3/16" holes in mounting flange or double sided adhesive
Enclosure rating	IP 42, NEMA 1
Shock and vibration	IEC 68 2-27, IEC 68 2-29, and EC 68 2-6
Operating temperature	-13...131°F (-25...55°C)
Storage temperature	-40...185°F (-40...85°C)
Approximate weight	0.9 lb. (400 g)

Technical Data

Interface to CRUZcontrol

Upstream connection	Male, 2X2, 4-PIN, 300 mm cable
Downstream connection	Female, 2X2, 4-PIN, 300 mm cable

Power

Supply voltage from daisy chain	18...30 VDC
Power consumption of ZIM	10 mA, no load
ZoneControl system power TB4 input	24...28 VDC typical. Limit values: 18...30 VDC

Input ratings

TB4 Power inputs +VDC, Common	24 VDC typical, 30 VDC max.
TB4 Release/Interrupt input	18...30 VDC
	Guaranteed OFF Voltage: <= 4.0 VDC
	Guaranteed ON Voltage: >= 15.0 VDC
	Typical ON state current draw @24V: 4mA
TB1 Single Release/Logic Interrupt ¹	18...250 UC ¹
	Guaranteed OFF Voltage: <= 4 UC
	Guaranteed ON Voltage: >= 15.0 UC
	Typical ON state current draw 2.5 mA
TB2 Slug Release input ¹	18...250 UC ¹
	Guaranteed OFF Voltage: <= 4 UC
	Guaranteed ON Voltage: >= 15.0 UC
	Typical ON state current draw 2.5 mA

Output ratings

TB5 Logic output	PNP; 2.21 kohm impedance typical
TB5 Zone Status output	PNP; 2.21 kohm impedance typical

Physical properties

Terminal block	
Terminal block wire	30 to 12 AWG (2.5 ... 0.2mm ² , strip length ¼" (6.0 mm)
Screw terminal torque	5 in-lbs. (0.56 Nm)
Housing	
Dimensions	5.125" x 3.75" x 1.125" (130mm x 95mm x 29mm)
Mounting	3/16" holes in mounting flange or double sided adhesive, any orientation
Enclosure rating	IP 42, NEMA 1
Shock and vibration	IEC 68 2-27, IEC 68 2-29, and EC 68 2-6
Operating temperature	-13...131°F (-25...55°C)
Storage temperature	-40...185°F (-40...85°C)
Approximate weight	0.9 lb. (400 g)

WORKS CITED

- OSHA. (2014). *Occupational Safety & Health Administration*. Retrieved 2014, from OSHA QuickTakes: <https://www.osha.gov/>
- SICK. (2019). *Sick Sensor Intelligence*. Retrieved from <https://www.sick.com/us/en/search?text=power-supply>

GENERAL INFORMATION

For additional manuals, videos, and other resources visit our website at:

www.FORTNA-conveyor.com

FORTNA

231.798.4547

Email : usinfo@fortna-conveyor.com

Web Site : fortna-conveyor.com



Manufacturing Location

FORTNA Inc.

131 Griffin Way

Mt. Washington, KY 40047

As standards, specifications, and design change from time to time, please ask for confirmation of the information given in this publication.

©2026 FORTNA Inc. All rights reserved.