

Installation, Operation, Maintenance Manual



NBC™ Belt **Narrow Belt Conveyor** Accumulation with CRUZcontrol® & Transportation

IOM Part Number: 1118140
Revision Date: January 24, 2023



Para la OIM española
seleccione aquí

TABLE OF CONTENTS

1 IOM INTRODUCTION	4
2 MHS/MHS CONVEYOR POLICIES	5
2.1 MHS RECOMMENDS PROPER LABELS FOR CONVEYOR TYPES.....	7
2.2 WARNINGS AND SAFETY INSTRUCTIONS	8
2.3 MHS CONVEYOR CONTROLS SAFETY GUIDELINES.....	11
4 NBC INTRODUCTION	13
4.1 NBC FLAT BELT ACCUMULATION AND TRANSPORTATION CONVEYOR	13
4.2 NBC GUIDELINES	15
4.3 NBC TECHNICAL APPLICATIONS	17
4.4 NBC GENERAL CAUTIONS.....	18
4.5 VALVE APPLICATIONS.....	19
4.6 DEFINITION OF TERMS	21
5 NBC RECEIVING AND SITE PREPARATION	22
5.1 PARTS INVENTORY AND IDENTIFICATION.....	24
6 NBC INSTALLATION DETAILS	25
6.1 DIMENSIONAL REFERENCE POINTS.....	25
6.2 SQUARING CONVEYOR	25
6.3 SUPPORTS & CONNECTIONS.....	27
6.4 ENVIRONMENT.....	27
6.5 COMPONENT ORIENTATION.....	27
6.6 ELEVATIONS	28
6.7 LINE STRAIGHTNESS.....	29
7 GEAR MOTOR ACTIVATION	30
8 NBC, NITTA BELT WELDING INSTRUCTIONS	32
9 THREADING THE BELT	34
9.1 THREADING BELT IN NBC TRANSPORTATION CONVEYOR	39
10 NBC AIR TAKE-UP	40
10.1 500 LB.-AT DRIVE TENSIONING (AIR TAKE-UP)	40
10.2 NBC CROSS SECTIONS	42
11 NBC SKEWING NBC ROLLERS	43
11.1 FACTORY SKEW CHARGE SECTION	43
11.2 MAINTENANCE SKEW SECTION	45
11.3 FINGER GUARDS FOR SKEWED MAINTENANCE PRESSURE ASSEMBLIES.....	46
11.4 ROLLER CENTERS 2”	46
11.5 ROLLER CENTERS 3”	48
11.6 CRUZ®CHANNEL TO XENOROL® CHANNEL CONNECTIONS	49
11.7 GUARDRAIL MOUNTING ON NBC	50
11.8 CRUZCHANNEL TO C6 NOSE PIECE.....	52
12 NBC AIR SUPPLY REQUIREMENTS	53
12.1 AIR PRESSURE APPLICATION	55
12.2 AIR REGULATOR LOCK OUT VALVE ON AND OFF POSITION	56

13 NBC LOGIC MODULE CONCEPTS	57
13.1 CRUZCONTROL® LOGIC.....	57
13.2 SETTING LOGIC MODULES	59
13.3 BASIC AND PROGRESSIVE LOGIC.....	60
13.4 NBC APPLICATION – CRUZ® LOGIC.....	64
13.5 A METHOD OF STOPPING THE COASTING PRODUCT	67
13.6 NBC COMPONENTS	69
13.7 FUNCTION MODULES.....	71
13.8 TERMINAL BLOCK DESCRIPTIONS.....	74
13.9 JUMPER DESCRIPTIONS	75
13.10 USE OF 115 VAC CONTROLS	76
13.11 FUNCTION MODULE PART NUMBERS.....	77
14 NBC POWER SUPPLY REQUIREMENTS	80
14.1 POWER SUPPLY REQUIREMENTS.....	80
14.2 POWER SUPPLY WIRING	81
14.3 ACCESSORIES.....	84
15 CRUZCONTROL ON SITE INSTALLATION.....	87
16 CONVEYOR FLOW.....	89
16.1 OVERVIEW – MHS CONVEYOR CRUZCONTROL LOGIC MODULE	96
16.2 POWER SUPPLY.....	101
17 NBC MAINTENANCE & TROUBLESHOOTING	109
17.1 GENERAL PREVENTIVE MAINTENANCE	109
17.2 TROUBLESHOOTING GUIDE – MECHANICAL/ELECTRICAL.....	113
18 NBC REPLACEMENT PARTS IDENTIFICATION.....	115
18.1 SPARE PARTS PRIORITY LEVEL EXPLANATIONS.....	115
18.2 NBC 500-AT DRIVE ASSEMBLY	116
18.3 NBC 500-AT AIR TAKE-UP.....	117
18.4 NBC 500-AT DRIVE TRAIN	118
18.5 REPLACEMENT PARTS - NBC 500 DRIVE TRAINS.....	118
18.6 NBC PRESSURE ASSEMBLY.....	119
18.7 NBC SKEWED PRESSURE PAN ASSEMBLY.....	120
18.8 NBC DISCHARGE BRAKE ASSEMBLY.....	121
18.9 NBC END PULLEY ASSEMBLY	122
18.10 NBC 12 FT. CONTACT ACCUMULATION	123
18.11 NBC LOGIC MODULE COMPONENT.....	124
18.12 NBC 12 FT. CONTACT ACCUMULATION SKEWED ROLLERS	125
18.13 NBC 12 FT. CONTACT ACCUMULATION SKEWED ROLLERS	126
NBC REVISION HISTORY.....	127
WORKS CITED	127
GENERAL MHS CONVEYOR	127
ABOUT MHS CONVEYOR.....	128

1 IOM INTRODUCTION

IOM Purpose

It is the intent of MHS Conveyor, through this manual, to provide information that acts as a guide in the installation, operation, and maintenance of MHS Conveyor conveyors.

This manual describes basic installation practices, assembly arrangements, preventive maintenance, and assists in replacement parts identification.

This service manual is intended for use by personnel who are knowledgeable of installation and safe working practices on conveyor systems.

Not all applications and conditions can be covered; therefore, this manual is to be used ONLY as a guide.

If additional copies of this manual are needed or if you have any question concerning the conveyor, please contact your MHS Distributor or MHS Lifetime Services at 231-798-4547 or visit MHS at www.mhs-conveyor.com for maintenance videos and other application information.

Manual Structure

You should receive a separate documentation for each product line of MHS Conveyor implemented in your installation. You can identify the respective product line on the back of the folder or on the cover sheet of the IOM (Installation Operation Maintenance Manual)

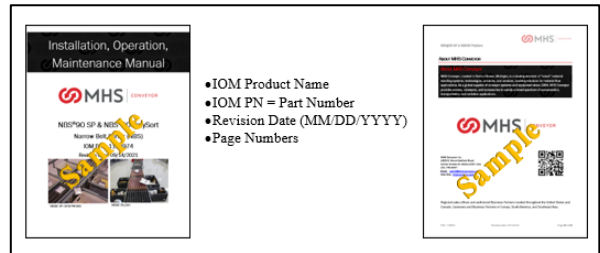

⚠ WARNING



- Pay attention to the safety instructions!
- Prior to working at or in the immediate vicinity of the system it is recommended that you make yourself familiar with the safety instructions included in the present document!

2 MHS MHS CONVEYOR POLICIES

MHS Conveyor Equipment Warranty

MHS Conveyor warrants that the material and workmanship entering into its equipment is merchantable and will be furnished in accordance with the specifications stated.

MHS Conveyor agrees to furnish the purchaser without charge any part proved defective within 2 years from date of shipment provided the purchaser gives MHS Conveyor immediate notice in writing and examination proves the claim that such materials or parts were defective when furnished. For drive components specific to XenoROL® (i.e., Xeno belts, slave Xeno belts, drive spools, standard and speed-up, and spacers), this warranty shall be extended to five years of running use, provided the conveyors are applied, installed and maintained in accordance with MHS Conveyor published standards. Other than the above, there are no warranties which extend beyond the description on the face hereof. Consequential damages of any sort are wholly excluded.

The liability of MHS Conveyor will be limited to the replacement cost of any defective part. All freight and installation costs relative to any warranted part will be at the expense of the purchaser. Any liability of MHS Conveyor under the warranties specified above is conditioned upon the equipment being installed, handled, operated, and maintained in accordance with the written instructions provided or approved in writing by MHS Conveyor.

The warranties specified above do not cover, and MHS Conveyor makes no warranties which extend to, damage to the equipment due to deterioration or wear occasioned by chemicals, abrasion, corrosion or erosion; Purchaser's misapplication, abuse, alteration, operation or maintenance; abnormal conditions of temperature or dirt; or operation of the equipment above rated capacities or in an otherwise improper manner.

THERE ARE NO WARRANTIES, EXPRESSED OR IMPLIED, INCLUDING, BUT NOT LIMITED TO, WARRANTIES OF MERCHANTABILITY OR FITNESS FOR A PARTICULAR PURPOSE, EXTENDING BEYOND THOSE SET FORTH IN THIS STATEMENT OF WARRANTY.

Rev 08/12/2021

MHS Environment Standards

MHS Conveyor equipment is designed to be installed in a clean, dry warehouse environment. Exposure to extreme humidity, direct sunlight, blowing dirt or rain can permanently damage some components of MHS Conveyor. In particular, the curing agents in concrete are known to attack and degrade the urethane conveyor components.

When installing conveyor on a new construction site, be sure that the concrete is properly cured before setting conveyor on it. In addition, if conveyors are stored in the proximity of curing concrete, proper ventilation must be used to direct the curing agent fumes away from the conveyor.

Failure to comply with these guidelines will void the MHS warranty on any failed components that result from these environment issues.

08/12/2021



WARNING



- Safety: Always lock out power source and follow recommended safety procedures.
<https://www.osha.gov/>

2.1 MHS RECOMMENDS PROPER LABELS FOR CONVEYOR TYPES

Shown below are some samples of labels applicable to conveyor standards.

CEMA Package Conveyors

SAFETY IS IN YOUR HANDS

Do Not Com. St. Stand, Walk, Run, or Trip on the Conveyor at Any Time	Do Not Perform Maintenance on Conveyor until Electrical, Air, Hydraulic and Gravity Energy Sources Have Been Locked Out and Stopped	Covered Equipment Only With All Approved Covers and Guards in Place
Do Not Load a Stopped Conveyor or Overload a Running Conveyor	Ensure That All Personnel Are Clear of Equipment Before Starting	Allow Only Authorized Personnel to Operate or Maintain Material Handling Equipment
Do Not Modify or Misuse Conveyor Controls	Keep Clothing, Body Parts and Hair Away From Conveyors	Remove Trash, Paperwork and Other Debris Only When Power is Locked Out
Ensure That All Controls and Pull Cords are Visible and Accessible	Know the Location and Function of All Stop and Start Controls	Report All Unsafe Conditions

POST IN PROMINENT AREA

Product: Unit Handling
Equipment: Motor Driven Live Roller Conveyors

To be placed along both sides of these conveyors since these conveyors provide surfaces and profiles attractive, but hazardous, for climbing, sitting, walking, or riding.

"A"
SPACE UP TO A MAXIMUM OF 20 FT. CENTERS (BOTH SIDES)

"C"
SPACE UP TO A MAXIMUM OF 20 FT. CENTERS (BOTH SIDES)

Optional Label to be placed either on the side or top of rails when space available does not permit application of the larger label.

"B"
SPACE UP TO A MAXIMUM OF 20 FT. CENTERS (Sides or top surface of both rails)

"D"
SPACE UP TO A MAXIMUM OF 20 FT. CENTERS (Sides or top surface of both rails)

"B"/"D" OPTIONAL

20' FT. MAXIMUM

"A"/"B"
"C"/"D"

NOTE: Due to the design of these conveyors, there may not be room on the side rails to place the larger labels. In that case, the smaller labels may be used. Optionally, they may also be placed on the top surface of both rails. The key is the space available and visibility by operators and maintainers.

CEMA - August, 2010 UH - 8

CEMA Safety Labels Placement Guidelines

Product: Unit Handling Equipment
Equipment: Live Roller Conveyors - Belt Driven

To be located on conveyors where there are exposed moving parts which must be guarded to facilitate function, i.e. rollers, pulleys, shafts, chains, etc.

To be placed along both sides of these conveyors since these conveyors provide surfaces and profiles attractive, but hazardous, for climbing, sitting, walking, or riding.

To be placed on removable guards to warn that operation of the machinery with guards removed would expose rollers, belts, gears, shafts, pulleys, impellers, etc. which create hazards.

"A"
LOCATE AT TERMINAL ENDS (BOTH SIDES)

"B"
SPACE UP TO A MAXIMUM OF 20 FT. CENTERS (BOTH SIDES)

"C"
LOCATE ON DRIVE GUARDS AND CHAIN/BELT GUARDS

"D"
LOCATE ON DRIVE SECTION (BOTH SIDES)

"A"
LOCATE ON DRIVE SECTION (BOTH SIDES)

"D"
LOCATE ON DRIVE SECTION (BOTH SIDES)

General guidance: Guard to warn maintenance personnel that conveyors should be shut off and locked out prior to servicing. Examples: drives, take-ups, take-back pulleys, which require guard removal.

UH-4

CEMA Safety Labels Placement Guidelines

Product: Unit Handling Equipment
Equipment: Belt Conveyors - End Driven

To be located on conveyors where there are exposed moving parts which must be guarded to facilitate function, i.e. rollers, pulleys, shafts, chains, etc.

To be placed along both sides of these conveyors since these conveyors provide surfaces and profiles attractive, but hazardous, for climbing, sitting, walking, or riding.

To be placed on removable guards to warn that operation of the machinery with guards removed would expose rollers, belts, gears, shafts, pulleys, impellers, etc. which create hazards.

"A"
LOCATE AT TERMINAL ENDS (BOTH SIDES)

"B"
SPACE UP TO A MAXIMUM OF 20 FT. CENTERS (BOTH SIDES)

"C"
LOCATE ON CHAIN GUARD

"D"
LOCATE ON DRIVE SECTION (BOTH SIDES)

"A"
LOCATE ON DRIVE SECTION (BOTH SIDES)

"D"
LOCATE ON DRIVE SECTION (BOTH SIDES)

General guidance: Label to warn maintenance personnel that conveyors should be shut off and locked out prior to servicing. Examples: drives, take-ups, take-back pulleys which require guard removal.

UH-2

Reference <https://cemanet.org/> for safety label guidelines.

2.2 WARNINGS AND SAFETY INSTRUCTIONS

Failure to follow the instructions and cautions throughout this manual and warning label on the conveyor may result in injury to personnel or damage to the equipment.

Your MHS Conveyor is powered by a motor and can be stopped only by turning off electrical power to the motor. As with all powered machinery, the drive-related components – including sprockets, chains, shafts, universal joints, and pneumatic devices – can be dangerous. We have installed or provided guards to prevent accidental contact with these parts, along with warning labels to identify the hazards.

Special attention must be paid to the following areas of this manual:

DANGER



- Indicates an imminently hazardous situation which, if not avoided, will result in death or serious injury. This signal word is to be limited to the most extreme situations.

WARNING



- Indicates potentially hazardous situation which, if not avoided, could result in minor or moderate injury. It may also be used to alert against unsafe practices.

CAUTION

- Indicates a potentially hazardous situation which, if not avoided, may result in minor or moderate injury. It may also be used to alert against unsafe practices.

2.2.1 Warnings and Safety Instructions



WARNING



- After maintenance, REPLACE guards immediately.
- Keep ALL warning labels clean and clear of any obstructions.
- Never remove, deface, or paint over WARNING or CAUTION labels. Any damaged label will be replaced by MHS Conveyor at no cost by contacting Lifetime Services.
- It is very important to instruct personnel in proper conveyor use including the location and function of all controls.
- Special emphasis must be given to emergency stop procedures.
- It is important to establish work procedures and access areas, which do not require any part of a person to be under the conveyor.
- It should be required that long hair is covered by caps or hairnets.
- Loose clothing, long hair, and jewelry must be kept away from moving equipment.
- Maintain enough clearance on each side of all conveyor units for safe adjustment and maintenance of all components.
- Provide crossovers or gates at sufficient intervals where needed to eliminate the temptation for personnel to climb over or under any conveyor.
- Walking or riding on a moving conveyor must be prohibited.
- Before performing maintenance on the conveyor, make sure the start-up controls are locked out and cannot be turned on by any person other than the one performing the maintenance.
- If more than, one crewmember is working on the conveyor, **EACH CREW MEMBER MUST HAVE A LOCK ON THE POWER LOCKOUT.**
- All pneumatic devices must be de-energized, and air removed to prevent accidental cycling of the device while performing general maintenance.
- Make sure all personnel are clear of all conveyor equipment before restarting the system.
- Before restarting a conveyor, which has been stopped because of an emergency, an inspection of the conveyor must be made, and the cause of the stoppage determined. The starting device must be locked out before any attempt is made to correct the cause of stoppage.

 WARNING	
	<ul style="list-style-type: none">• Before servicing or performing any work in the motor control panel, disconnect and lock out air and the main incoming service. If only the panel disconnect is off, the incoming side will still be hot. <div style="text-align: center;"><p>CHR930009</p></div> <p style="text-align: center;"><i>Safety WARNING Label Lock Out Power</i></p>

2.3 MHS CONVEYOR CONTROLS SAFETY GUIDELINES

The following basic conveyor control safety guidelines are recommended by MHS Conveyor even though Business Partner may or may not purchase conveyor controls from MHS Conveyor. The items listed deal with applications of controls equipment. The actual installation of the equipment must always follow the National Electric Code and all other local codes.

Start-up Warning Horn

Ideally, all conveyors should be within sight of the conveyor start pushbutton. This allows the operator to verify that no one is touching the conveyor or would be in danger if the conveyor were to start up. If it is not possible to see the entire conveyor being started from the start pushbutton location, then some form of audible warning device is required. It could be a horn, buzzer, bell, or anything unique to that conveyor for that location. It should be loud enough to be heard at any point on the conveyor system. It should sound for approximately five seconds after the start pushbutton is pushed, prior to the actual running of conveyor. Any auxiliary equipment such as vertical lifts, turntables, etc., should also be included in the warning circuitry.

Conveyors that stop and restart under automatic control could also require a horn warning prior to restarting. If it is not easy to distinguish the difference between a fully stopped conveyor system and a momentarily stopped conveyor section, then it is advisable to add a warning horn. All conveyor sections that stop and restart automatically should be marked with appropriate signs or labels.

Start Pushbuttons

Start pushbuttons should be the flush type or guarded such that inadvertently leaning against them will not actuate the conveyor. They should be provided with a legend plate clearly defining which conveyors will be started.

Stop Pushbuttons

Stop pushbuttons should be the extended type such that any contact with it is sufficient to stop the conveyor. They would also be provided with a legend plate clearly defining which conveyors will be stopped.

Operator Controls

Additional operator controls should be designed into the system with the same guidelines that go into start and stop pushbuttons, depending upon their function. Devices which are repeated on multiple control stations, such as emergency stops, should be located at the same relative location on each station (such as lower right corner).

Emergency Stops

All locations where an operator must work directly at the conveyor should be protected by an emergency stop. An operator should not have to move from where he is to actuate the emergency stop.

Conveyors in areas of high pedestrian traffic should also be protected by emergency stop devices.

For all other instances, emergency stops should be located throughout a system such that it is possible to shut down the system without having to walk too far. In these instances, the emergency stop is used more to protect the equipment from damage than to protect personnel.

Emergency stops can be of the pushbutton or cable operated switch type. The pushbutton type should be a red, mushroom head maintained pushbutton which requires resetting after it is actuated. Cable operated switches should trip by pulling the cable and require resetting at the switch.

Actuating an emergency stop must drop-out the start circuit, requiring restarting the system using the start pushbuttons provided.

An emergency stop should normally stop all conveyors in the system. Very large systems may involve dividing a system into zones of control based on proximity of personnel, safety hazards, walls obstacles, etc.

Controls Logic

Solid state controls logic devices, such as programmable controllers are used extensively for conveyor control. They are very reliable, but a hardware failure or software bug would cause an output to function erratically. For this reason, start circuits, warning horn circuits, and emergency stops should usually be configured using conventional relay logic.

Safety Switches

All conveyor control cabinets and motors should be provided with safety (or disconnect) switches. These switches must have provisions for padlocking. As required for maintenance, equipment should be locked in the off position.

Special Devices

Special devices and equipment such as vertical lifts, turntables, high speed conveyors, etc., all have unique design and safety requirements. These should be looked at in each case to determine what the requirements might be.

Rev 08/12/2021

4 NBC INTRODUCTION



NBC flat belt contact accumulation

4.1 NBC FLAT BELT ACCUMULATION AND TRANSPORTATION CONVEYOR

Concept and Operation

NBC flat belt conveyor is offered in contact accumulation and transportation versions.

The conveyor differences are as follows:

Contact Accumulation

The NBC contact accumulation zones are 4' long but operate in such a manner as to allow mixed length product to dense pack accumulate. The products are allowed to touch and bump but are at zero-pressure accumulation after they stop. The minimum speed for dense packing of product is 90 FPM for totes and 125 FPM for corrugated product.

The product-carrying rollers are driven by a nominal 1.75" wide belt. This belt is held in contact with the underside of the carrying rollers by spring pressure roller channel assemblies, mounted on the conveyor side channels.

Accumulation begins when a product blocks the first sensor from the discharge end. The first product stops over the discharge sensor which "arms" the next sensor upstream while lowering the belt pressure roller channel in that zone.

When a zone accumulates, each spring pressure roller channel assembly in that zone lowers by the use of an air diaphragm. The belt is lowered away from the carrying rollers causing them to become non-powered. Products are conveyed to the zone; then coast as they enter the non-powered area and bump into the stopped downstream product. As accumulation takes place from zone-to-zone, the accumulated products are at zero-line-pressure.

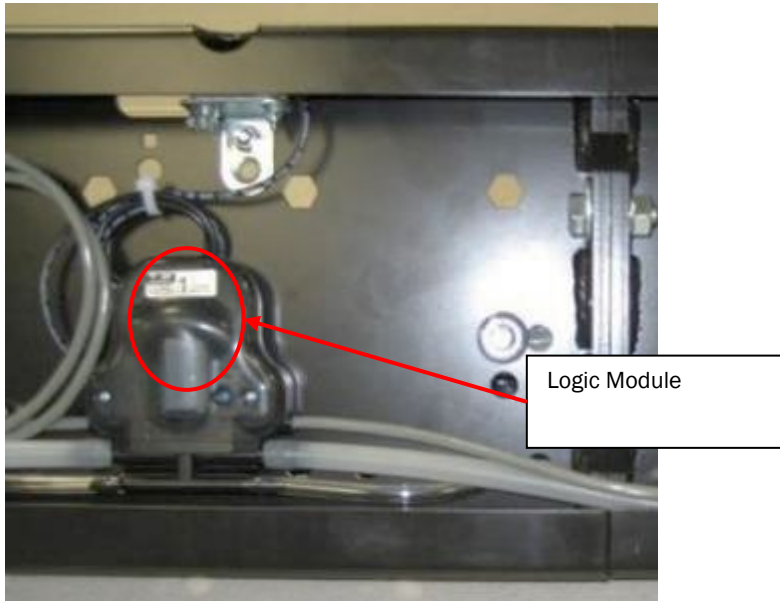

NBC Logic Module Assembly

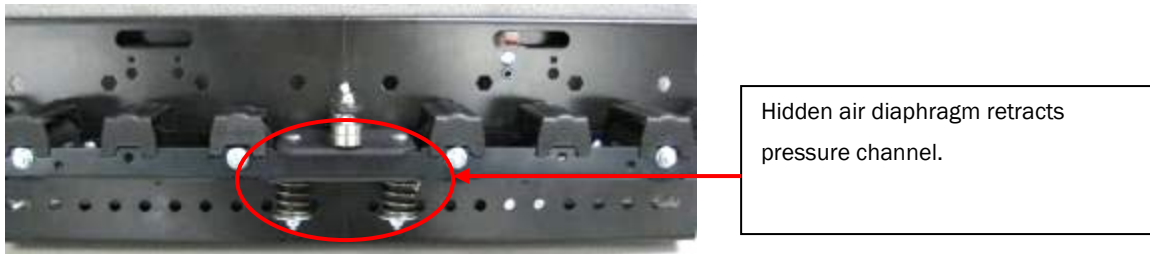

NBC Pressure Pan – spring-to-drive rollers, air-to-accumulate.

Transportation

The NBC transportation has the same spring-loaded pressure pans as the accumulation versions, but no air diaphragm to disengage the pressure pan. A plastic Cam can be manually activated to lock the pressure pan in the down position for ease of belt installation. However, once the plastic Cam is manually deactivated, the pressure pan always holds the drive belt in contact with the carrier roller.

Air Transportation

Air transportation uses air diaphragms to retract the pressure assemblies rather than the plastic lockout Cam. All the diaphragms are linked together to a central valve which is designed to disengage the entire line at once. There are no logic modules for individual zone accumulation.

4.2 NBC GUIDELINES

1. Accumulation or transportation as required.
2. Product-to-product contact is allowed.
3. Singulation of product release is not required.
4. Product weight: 1-75 lbs. (50 lbs. /ft.)
5. Product height: 1" minimum
6. Product may be same size and weight, or mixed.
7. Air supply is dry.

Application Notes

1. NBC does not singulate products.
2. Conveyor operations before and after NBC are vital to proper application decisions.
3. The conveyor downstream from progressive release NBC must run at a speed which allows it to receive products as fast as they are released from the NBC conveyor.
4. There will not be a gap or means of detecting a specific product, directly on the end of NBC without a downstream speed-up bed.
5. When feeding sortation from NBC, use a split metering belt to singulate individual products when specific minimum gap is required.
6. NBC cannot be fed from an upstream conveyor at a rate exceeding the NBC rate, especially from a curve.
7. Convey all products along one side of NBC unless products are nearly the same width and closely match the conveyor width. Skewing beds are available to accomplish this.
8. During accumulation, product density (packing) increases with product weight and speed.
9. For all applications, Nitta belt shall be used.
10. Under no circumstances shall a mechanical lace be used with the Nitta blue urethane welded belt MHS Conveyor P/N 1205548.
11. NBC conveyor requires a MHS Conveyor Nitta Belt Welding Tool Kit for splicing the belt. This tool kit was developed by Nitta Corporation for MHS Conveyor NBC belt requirements and are available only from MHS Conveyor.
12. Limit the length of NBC conveyors to 220'. If you have a requirement beyond 220' contact Applications Engineering.
13. Always locate the drive bed at the charge end of the primary conveyor.
14. Totes may have up to a 2" taper on each end without affecting the function of the electronic sensors. Customers who have tapered totes may request MHS Conveyor to perform a product test with test product supplied by the customer.
15. All accumulation conveyors require a discharge brake zone up to 129 FPM unless discharging to belt unit. For speeds at 130 FPM and above, a pivoting blade stop, blade stop, or brake belt unit is required.
16. Due to the direct drive train, speeds may vary +/- 10% from stated speeds.
17. The minimum bed length for all NBC Flat Belt drives is 8'.
18. The 500-AT has an air take-up with a maximum belt take-up of 55", a maximum belt pull of 500 lbs. and is used for lengths from 12' up to 220'.
19. Use the NBC Application Program to determine the horsepower size based on rate and speed requirements.
20. Take away speed to be equal or greater than NBC Flat Belt.

21. Pricing includes bed, end assemblies, and belting.
22. Floor supports are not included. See Support and Connections for details.
23. Maximum amount of continuous skew is 12' not including maintenance skews.

Temperature

24. Ambient temperature is +35° to +120° F for Nitta belts.
25. For applications outside this temperature range, contact Applications Engineering.

4.3 NBC TECHNICAL APPLICATIONS

Product delivery (release) following accumulation is always an important application consideration. The product release rate depends on the release logic, conveyor speed, gaps between products, and the product length. In all situations that require dense product packing, the conveyor should NOT run below 125 FPM for cartons and 90 FPM for totes.

Release efficiency is the ratio between conveyor speed (feet per minute) and the product footage delivered (case feet per minute). One variable is the amount of gaps between products before release. These gaps are due to product coast when accumulating. (See Coast-ability) Additional gaps can occur at release dependent on the logic used.

When dense packing in a cool environment (35° to 50°) a minimum speed of 150 FPM is required.

Release Efficiencies

Overall release efficiency with a single continuous release may vary.

- Contact Accumulation
- 40% with Basic Logic (40% product / 60% air)
- 80% with Progressive Logic (80% product / 20% air)

Release efficiencies are dependent on the case size, mix, weight, conveyor speed, whether Basic or Progressive logic is used with the release operation. When the speed to meet rate using Basic Logic is over 150 FPM, consider using Progressive Logic

In the progressive release mode for contact accumulation, it is extremely important to set every 5th logic module to basic.

Discharge Zone

A function module is provided for the discharge bed prior to shipping. If the NBC line is feeding another NBC line, a release type function module is not required.

Horsepower Principles

The horsepower required for NBC conveyor is based on the effort (in pounds) to pull the belt through the conveyor (belt pull), turning all the rollers and moving the product at a given speed. Actual horsepower is based on “effective belt pull”, which includes a factor for belt flexing, bending, and snubbing.

Coast ability

Product coast is affected by many factors involving the product and conveyor. When one product does not coast up to the previous product, a gap occurs. Some gaps are likely within a zone. This is not a problem if considered when determining the conveyor

speed. Factors determining coast are; product bottom - smoothness, firmness, straightness; product weight; product length relative to zone length; conveyor speed; roller bearing friction, rollers still turning from previous product movement or rollers which have stopped.

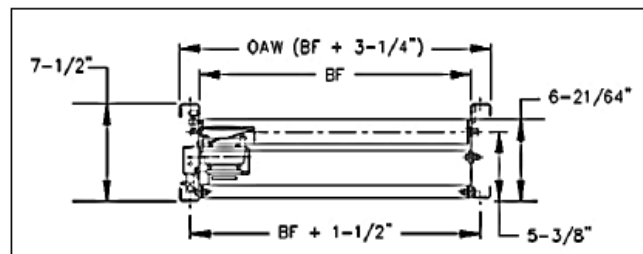

4.4 NBC GENERAL CAUTIONS

- Singulating individual product out of NBC requires a MHS Conveyor application review. Consult Applications Engineering for available options.
- Do not pitch NBC either up or down. When product accumulates, the conveyor turns to gravity and product control is lost.
- Do not overfeed downstream conveyor with either Basic or Progressive release. This will create line pressure.
- The minimum package length is 9". The minimum package height is 1". The maximum product weight is 50 lbs. /ft.
- Small light products that fit between a zone sensor and the end of the zone may rotate and/or accumulate side by side. Consult Applications Engineering for available options.
- Rollers in the center 4' zone in all 12' intermediate beds are designed to skew if required. No other rollers in the bed can be skewed. Any NBC conveyor that has skewed rollers without proper installation will immediately and permanently **VOID ALL MHS Conveyor WARRANTIES.**
- Make sure air is preset, and take-up engages before operating the NBC conveyor.

4.5 VALVE APPLICATIONS

NBC Air Transportation Conveyor

NBC Flat Belt Air Transportation is typically used in conjunction with a downstream NBC Flat Belt Contact Accumulation conveyor.

Air Pilot Valve

NBC Air Transportation should be used when downstream accumulation is full. The air pilot valve receives a signal from the last downstream accumulation zone and disengages the pressure pan assemblies for the entire unit. Once the downstream zone clears, the pilot valve engages the pressure pan assemblies and the transportation conveyor will continue to transport the products. The pilot valve can be replaced with a solenoid valve and controlled through a PLC.

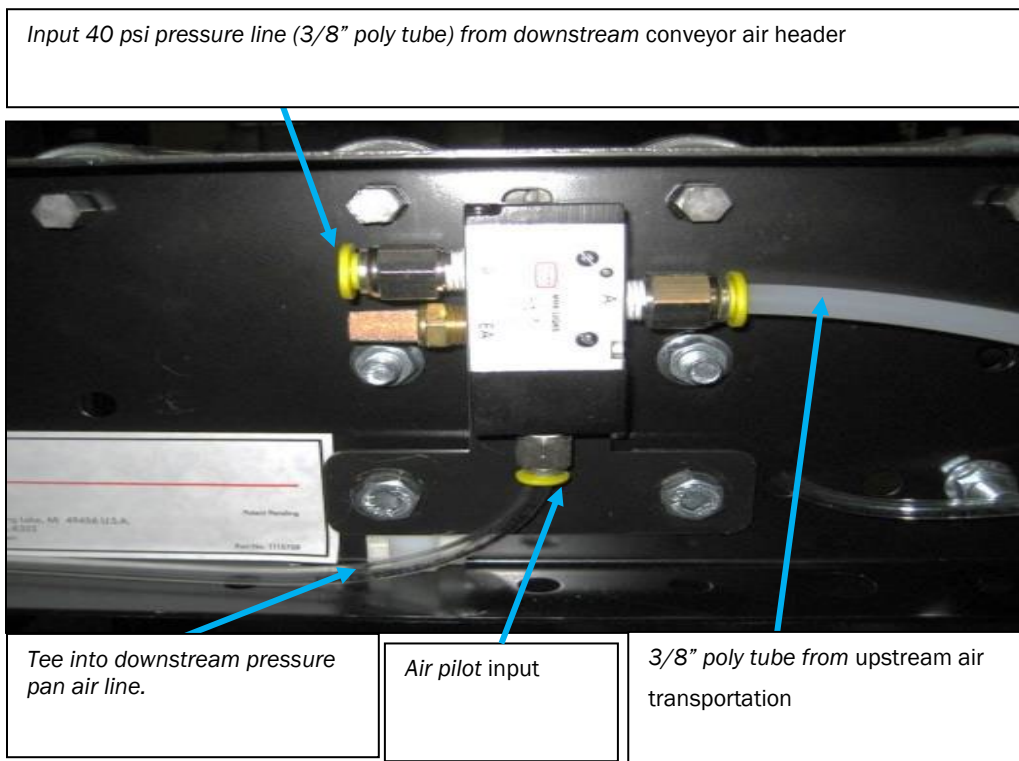

Pilot Valve	
Item#	Description
1120400	VALVE,PNEU-PILOT-A48

Solenoid valve

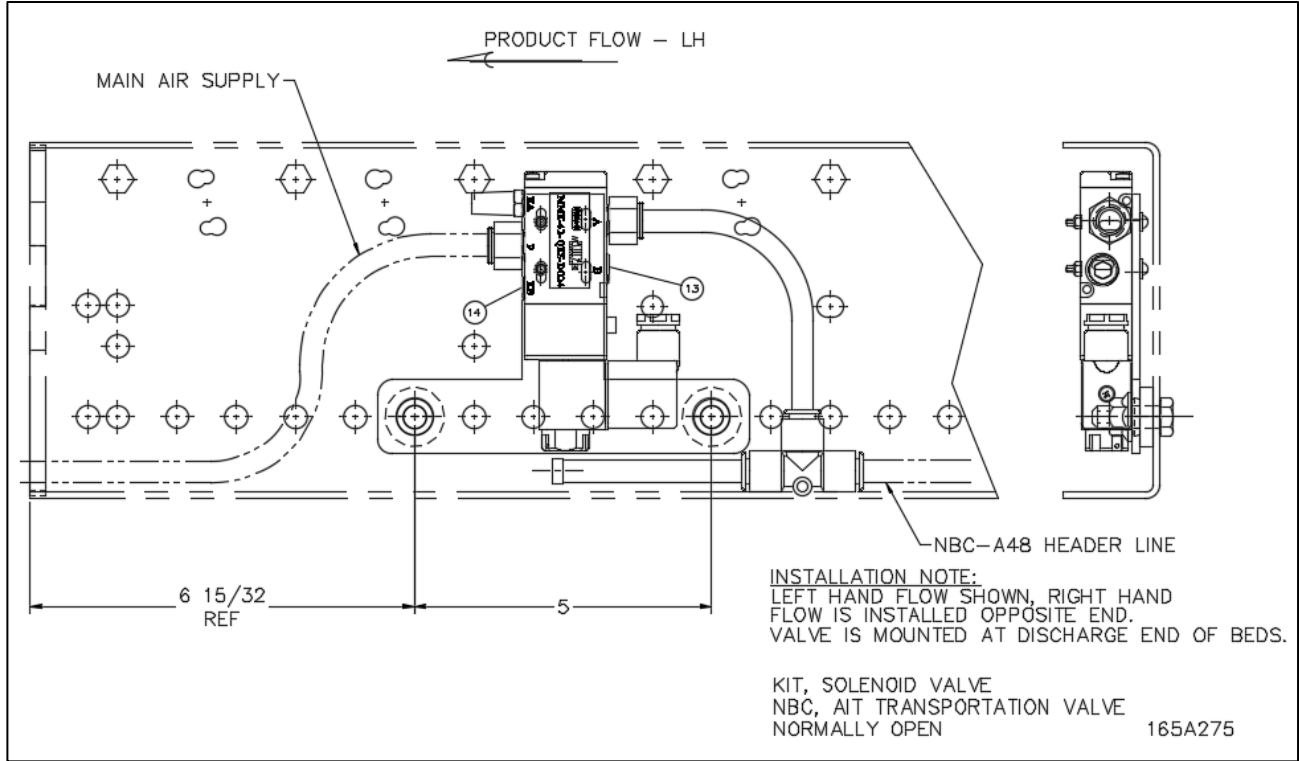

The Solenoid Valve Kit is controlled by an external signal from the primary control system supplied by the purchaser. The Solenoid Valve Kit is typically mounted near the last NBC contact accumulation zone prior to the upstream NBC Air Transportation conveyor.

Solenoid Valve	
Item#	Description
1206186	KIT,CPART-SOL VALVE-24V-NBC AIR TRANS-VALVE OPEN
1206187	KIT,CPART-SOL VALVE-110V-NBC AIR TRANS-VALVE OPEN

The valve is normally open when no signal is present, which causes the NBC Air Transportation conveyor to stop or accumulate. When the last NBC Contact Accumulation zone clears, a control signal triggers the Solenoid Valve to activate (close or stop the air flow), and the NBC Air Transportation conveyor will activate and convey the product downstream. Review the detail above to determine correct Pilot or Solenoid Valve Kit on the NBC Contact Accumulation conveyor flow.

4.6 DEFINITION OF TERMS

Logic Assembly

The logic assembly is used to setup the type of automatic accumulation of product on the conveyor.

ATB

Air-to-brake (Type of Logic assembly used in NBC conveyors – Normally Open Valve)

Function Module

The function module provides electrical isolation for external signals used to control a CRUZcontrol system.

Downstream or Upstream

In this manual, it is always in reference to product conveyor flow.

OFF

Off indicates a logical low signal and/or no power. For example, if a logic line is OFF, there is no power on the logic line.

ON

On indicates a logical high signal and/or powered. For example, if a slug line is ON, then there is power on the slug line.

Zone status

The zone is considered full if the local zone's sensor detects a package. The zone is empty if it does not detect a package.

JP#, #-#

JP stands for "jumper terminal" and the number indicates which jumper terminal is being referenced. The "#-#" refers to the pins that are connected by the actual jumper. NC means the jumper is not connected to any terminal.

Ex. jumper terminal #1 pins 1 & 2 (JP1, 1-2)

TB#, #-#

TB stands for "terminal block" and the number indicates which terminal block is being referenced. The "#-#" refers to the pins that are being used on that terminal block.

Ex. terminal block #1 pins 1 & 2 (TB1, 1-2)

5 NBC RECEIVING AND SITE PREPARATION

Receiving

MHS Conveyor NBC flat belt conveyors are shipped in subassemblies. These subassemblies are packaged to guard against damage in shipment when handled properly.

Examination immediately following unloading will show if any damage was caused during shipment. If damage is evident, claims for recovery of expenses to repair damaged or replace components must be made against the carrier immediately. While unloading, a check must be made against the Bill of Lading, or other packing lists provided, to confirm full receipt of listed items.

CAUTION

- TAKE CARE DURING THE REMOVAL OF EQUIPMENT FROM THE CARRIER. Remove small items and boxes first. Pull and lift only on the skid, not on the frame, crossmember or any part of the equipment.
- Be sure the skid is free of other materials which may be on top of or against the side of the skid to be removed.



NBC Conveyor ready for shipment

Preparation of Site

After the conveyor is received, move it to the installation site or designated dry storage area as soon as possible. Clean up all packing material immediately before parts are lost in it, or accidentally discarded. Loose parts should remain in the shipping boxes until needed. Prior to starting the assembly of the conveyor, carefully check the installation path to be sure there are no obstructions that will cause interference. Check for access along the path needed to bring in bed sections and components closest to

the point where they are needed. It is often necessary to give the area along the system path a general cleanup to improve installation efficiency, access, and accuracy.

5.1 PARTS INVENTORY AND IDENTIFICATION

Each subassembly is shipped completely assembled except typical loose parts, which are in boxes with the subassemblies. Segregate the conveyor subassemblies by types for inventory and ease of locating during installation.

An identification label is attached to the outside of one side channel close to one end of each conveyor bed and on all drive packages. On supports, the tag is located on the crossmember. Labels **may** contain the following information:

New style labels have the following:

- Item number
- Description
- Job Number
- Mfg. Number
- Tag number (if specified)
- Assembler's clock number
- Date of manufacture
- QR (Quick Response) bar code
 - Scan bar code for IOM manual



If Applicable - Scan the QR code to retrieve the IOM Manual, if nothing happens; check your scanner settings to make sure the QR Label setting is enabled. On the supports, the tag is located on the bottom side of the foot.

On special devices, it is located on a convenient flat surface that is not offensive to the appearance of the equipment but is still accessible for viewing. These numbers can be cross-referenced against the packing list.

Loose parts are boxed and shipped separately. You should have all conveyor sections and supports for a particular conveyor prior to installation. It is cost-effective to identify and procure any missing parts before they are needed for assembly. Small items like nuts and bolts are weigh-counted and packaged by size and type.







NBC Identification labels

6 NBC INSTALLATION DETAILS

NBC General Procedures

The following procedures are to be used as guidelines only. Specific installation methods will vary somewhat depending on available equipment on site and each installer's preferences based on experience.

 WARNING	
	<ul style="list-style-type: none"> The Installation Supervisor must be experienced with conveyor, qualified in the mechanics of the equipment, enforce safe working procedures for the protection of the crew, customer, and customer's property.

 WARNING	
	<ul style="list-style-type: none"> Before restarting a conveyor, which has been stopped because of an emergency, an inspection of the conveyor must be made, and the cause of the stoppage determined. The starting device must be locked out before any attempt is made to correct the cause of stoppage.

6.1 DIMENSIONAL REFERENCE POINTS

The path of each conveyor in the system is determined by establishing a reference point at each end. The center line of the conveyor is established and a chalk line is snapped between these points.

Conveyors should be installed with the center line of the bed matching the center line of the conveyor path within 1/8" of true center. Locate and mark the center of the crossmembers at each end of the conveyor. Use a plumb line or other acceptable means to ensure accuracy to the chalk line.

Always carry out a thorough check for any obstructions such as building columns, manholes, etc. It may be necessary to reroute the conveyor to avoid the obstruction. In this case it would be advisable to begin installation at this point, using the obstruction as a reference point (Datum), and install the section in either direction as required.

6.2 SQUARING CONVEYOR

All conveyor sections must be checked for squareness prior to installation as "racked" or being knocked out of square may have occurred during shipping and handling. An out of square conveyor section is a

leading cause of belt mistracking. Measure diagonally across the four corners of the conveyor frame to determine if frame is out of square. If the measurement is not equal between the two diagonals, the frame is not square. A “racked” conveyor will skew the rollers, causing the belt to wander off center.

The conveyor sections are joined together with welded butt plate connectors. If a conveyor section is determined to be out of square, adjustment must be made before proceeding to the next section. Correct the squareness of the conveyor frame by installing a tie rod along the longest diagonal dimension and adjusting the turnbuckle until the diagonal measurements are equal in length. It is important to loosen the support and connection hardware before attempting any adjustment.

If gaps appear between bed joints as a result of squaring the conveyor, take care not to “re-rack” the conveyor by pulling the sections together at the bed joints. Insert optional shim plates or washers to the required thickness to fill the gap before tightening the connection hardware. Verify the squareness of the conveyor after installation.

CAUTION

- An out of square conveyor section is a leading cause of belt mistracking.

LOOSEN SUPPORT AND CONNECTION HARDWARE BEFORE ATTEMPTING ANY ADJUSTMENT.

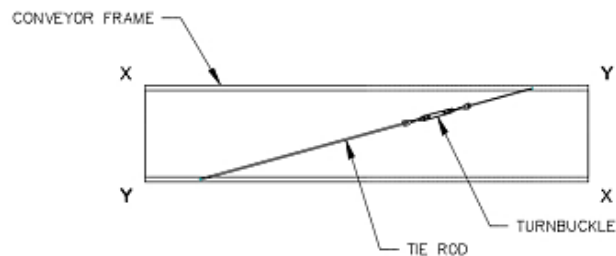

MEASURE DIAGONALLY ACROSS THE FOUR CORNERS.
 IF Y-Y DIMENSION IS GREATER THAN X-X, ASSEMBLY TIE ROD AS SHOWN.
 IF X-X DIMENSION IS GREATER THAN Y-Y, ASSEMBLY TIE ROD ACROSS THE OPPOSITE DIAGONALS.
 ADJUST TURNBUCKLE UNTIL DIAGONAL MEASUREMENTS ARE EQUAL IN LENGTH ($\pm 1/16$ ”).

IOM-NBC031

Squaring conveyor.

6.3 SUPPORTS & CONNECTIONS

For details on Supports & Connections, see Support & Connections IOM (#1200485) at mhs-conveyor.com

6.4 ENVIRONMENT

Temperature range (ambient):

+35° to +120°F. For applications that exceed this temperature range, please consult Applications Engineering.

Oily or Wet Conditions:

Will impair frictional drive characteristics.

Corrosive or Abrasive Substances:

Will adversely affect various components.

6.5 COMPONENT ORIENTATION

Using your conveyor system layout drawing and the numbers on the I.D. tags of each component position and orient the conveyor section.

You must know:

- The direction of product flow
- The elevation height
- How the drive is positioned
- Charge and discharge end beds

IMPORTANT! Do not make alterations to the equipment without consulting with user's representative and MHS Conveyor. Unauthorized modifications to the equipment may impair its functions, create a hazardous condition, affect its useful life and /or void the warranty.

6.6 ELEVATIONS

All conveyor sections should be installed in accordance with the elevations shown on the drawings. In addition, they must be level across the frame width and length (if horizontal). Leveling of the frames is best done using a rotating laser level or builder's level.

After the first elevation is established at a critical point, the elevation of all other points shall be relative to this first point. Normal practice is to dimension the layout and measure elevations from the floor at each point of support.

As the conveyor system proceeds onto another floor or into another building or room, a new elevation will be measured from the floor at that point. The new elevation will then become the reference from subsequent elevations.

When installing an overhead system, the first elevation is measured from the floor and becomes the reference elevation point until a change in the elevation is shown on the layout. Any new elevation is also measured from the floor and becomes the new reference point. The process is repeated each time an elevation change occurs.

CAUTION

- Consult the building architect or a structural engineer regarding ceiling loading or structural limitations of the building if any conveyor section is ceiling hung.
- MHS Conveyor is not responsible for permits regarding ceiling load data.

6.7 LINE STRAIGHTNESS

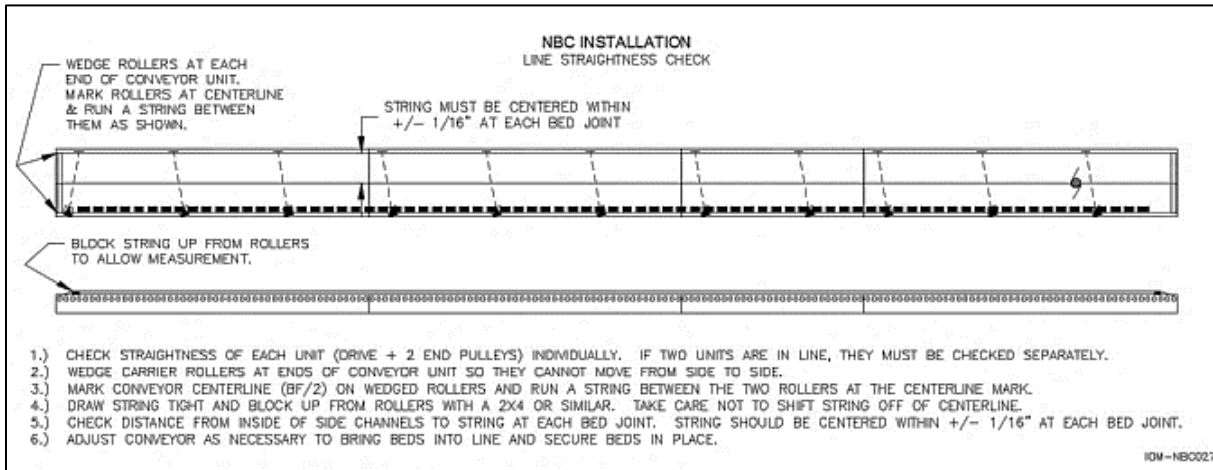



CAUTION

- Line straightness must be maintained, or belt will miss-track and result in damage to the conveyor.

7 GEAR MOTOR ACTIVATION

PRIOR to systems activation - Please inspect the gear unit for a vent and if applicable to the product remove the rubber sealing plug to activate. The vent is designed to allow excessive pressure to escape. Each gear unit should have a yellow instruction tag as shown below. The tag can be removed after the plug is removed.

NOTE: The rubber sealing plug is in place for shipping and storage purpose only.

 WARNING	
	<ul style="list-style-type: none"> In order for the gear motor to release pressure, the vent must be activated by removing the rubber sealing plug PRIOR to gear unit start up.

Please check you gear unit for a vent and if applicable to your product, remove the sealing plug to activate. "<https://www5.nord.com>" Operation Manual for Gear Units (B1000).

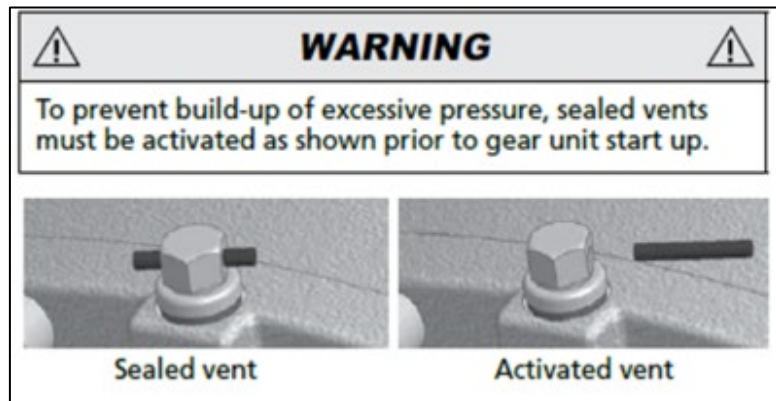

NOTE: Yellow tags may be tucked out of sight. Please inspect all motors for a vent and remove sealing plug, if present, to activate.

The following pictures are examples showing where vent plugs may be located depending on the product line and motor position.

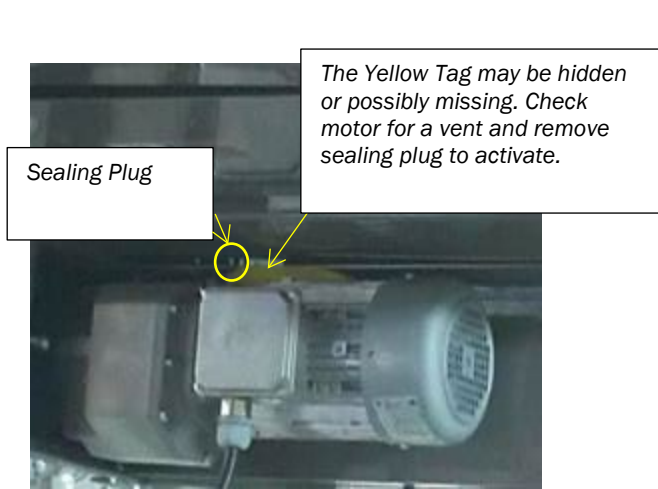

8 NBC, NITTA BELT WELDING INSTRUCTIONS

Sample of NBC, MHS Conveyor Nitta Belt Welding Instruction.

To rent or purchase parts contact MHS Conveyor Lifetime Services at 231-798-4547.

MHS Conveyor Nitta Belt Weld Instruction Manual #1120515 or

MHS Conveyor Nitta Belt Weld Instruction Maintenance Video at:

mhs-conveyor.com

MHS ConveyorNitta Belt Welder Press Rental Kit:

MHS Conveyor NITTA BELT FULL WELD & PUNCH KITS (RENTAL KITS ONLY!)	
Item #	Description
1207112	TOOL,NBC-NITTA-RENTAL-WELDER KIT-FULL
MHS Conveyor Rental Kit Include: Finger Punch Press, T-wrench, Heated Weld Press, Pre-setter Mold, Silicone Sheet, Instruction Manuals, and Flash Drive with Instruction Video. Each Press Kit Is Shipped in a Hard Case.	
NITTA BELT WELDER AND PUNCH HARD CASE WITH SPECIAL MOBRIK FOAM	
Item #	Description
1211171	CASE, PELICAN 1560-000-110-BLACK CASE, W/ SPECIAL MOBRIK-FOAM #BW1560 (HOLDS THE WELDER & PRESETTER)
1211172	CASE, PELICAN 1620-020-110-BLACK CASE, W/ SPECIAL MOBRIK-FOAM #BW1620 (HOLDS THE PUNCHER)



CAUTION

WARNING:

- Use Only MHS Conveyor Nitta belt welder and punch equipment for MHS Conveyor Nitta belt splice/welding. Non-MHS Conveyor Nitta belt welding or punch equipment is not compatible with the MHS Conveyor Nitta belt!

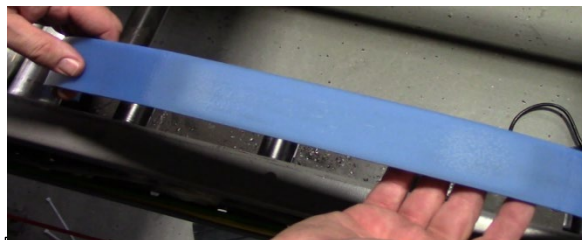

Top side of blue urethane belt after weld

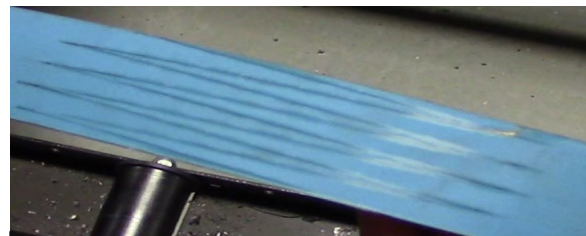

Bottom side of blue urethane belt after weld

CAUTION

- Never field splice NBC Nitta blue urethane belt (MHS Conveyor P/N 1205548) with mechanical lacing, as the belt fabric is not designed to hold lacing.

8.1.1 Replacement Parts - Nitta belt Welding

MHS Conveyor NITTA BELT FULL WELD & PUNCH KITS (RENTAL KITS ONLY!)	
Item#	Description
1207112	TOOL,NBC-NITTA-RENTAL-WELDER KIT-FULL
MHS Conveyor Rental Kit Include: Finger Punch Press, T-wrench, Heated Weld Press, Pre-setter Mold, Silicone Sheet, Instruction Manuals, and Flash Drive with Instruction Video. Each Press Kit is Shipped in a Hard Case.	
NITTA BELT WELDER AND PUNCH HARD CASE WITH SPECIAL MOBRIK FOAM	
Item#	Description
1211171	CASE, PELICAN 1560-000-110-BLACK CASE, W/ SPECIAL MOBRIK-FOAM #BW 1560 (HOLDS THE WELDER & PRE SETTER)
1211172	CASE, PELICAN 1620-020-110-BLACK CASE, W/ SPECIAL MOBRIK-FOAM #BW 1620 (HOLDS THE PUNCHER)
NITTA BELT	
Item#	Description
1205548	BELT,NBC-1.75"W-CFTG-BLU-U-WLD (WELD ONLY!)
NBC NITTA BELT COMPLETE WELDER KIT (PURCHASE ONLY)	
Item#	Description
1207241	TOOL,NBC-NITTA-PURCHASE-WELDER KIT-FULL
Include: Heated Weld Press and Nitta NPS-2005-1/2 Manual , Finger Punch Press, T-wrench & Nitta FP-200T Manual, & Pre-setter Mold with 1 Silicone Sheet	
WELDING PRESS	
Item#	Description
1204524	TOOL,NBC-NITTA BELT-PRESS-HEATING/COOLING 110V
1204526	TOOL,NBC-NITTA-SILICONE SHEET-USE WITH PRE-SETTER Include: Heated Weld Press & Nitta NPS-2005-1/2 Manual
REPLACEMENT PARTS - FOR WELDING PRESS	
Item#	Description
1207117	TOOL,NBC-NITTA BELT-PRE-SETTER-W/SILICONE SHEET-1.75"W
FINGER PUNCH PRESS	
Item#	Description
1204525	TOOL,NBC-NITTA BELT-PUNCHER-FINGER PUNCHER Include: Finger Punch Press, T-wrench & Nitta FP-200T Manual
REPLACEMENT PARTS - FOR FINGER PUNCH PRESS	
Item#	Description
1207004	TOOL,CPART-NITTA-BLADE(2)-CUTTERS FOR USE WITH FP-200T
1207118	TOOL,NBC-NITTA-T-WRENCH-USE WITH PUNCH PRESS
1207119	TOOL,NBC-NITTA-CUTTING BOARD-USE WITH PUNCH PRESS
1215576	SCREW, HEX HEAD NITTA-NO2-FP200-A003-19
1215577	TABLE,ALGND NITTA-NO2-FP200-P011-E-RA



MHS Conveyor P/N 1204526: Pre-setter Mold & Silicone Sheet

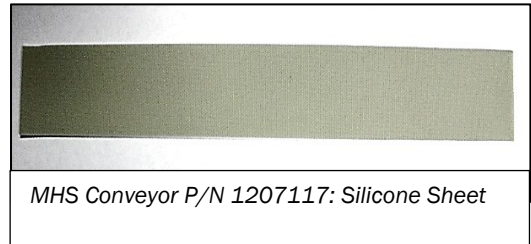

MHS Conveyor P/N 1207117: Silicone Sheet

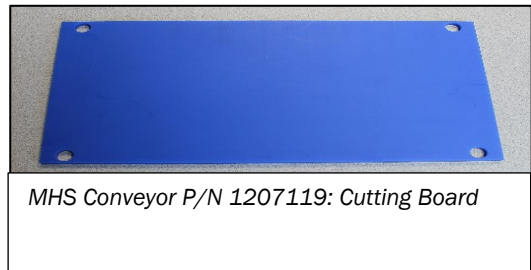

MHS Conveyor P/N 1207119: Cutting Board

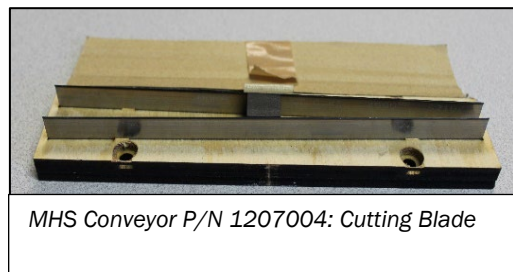

MHS Conveyor P/N 1207004: Cutting Blade

9 THREADING THE BELT

Step 1

The most important item in threading NBC belts is to **turn the system air ON with NO POWER to the logic modules**. This will depress the pressure pans and open up a belt path. Without air, all the rollers are engaged as NBC is a spring-to-drive system and it will be extremely difficult to thread the belt.

NOTE – Use the slide switch located at the take-up cylinder base to turn the air take-up OFF.

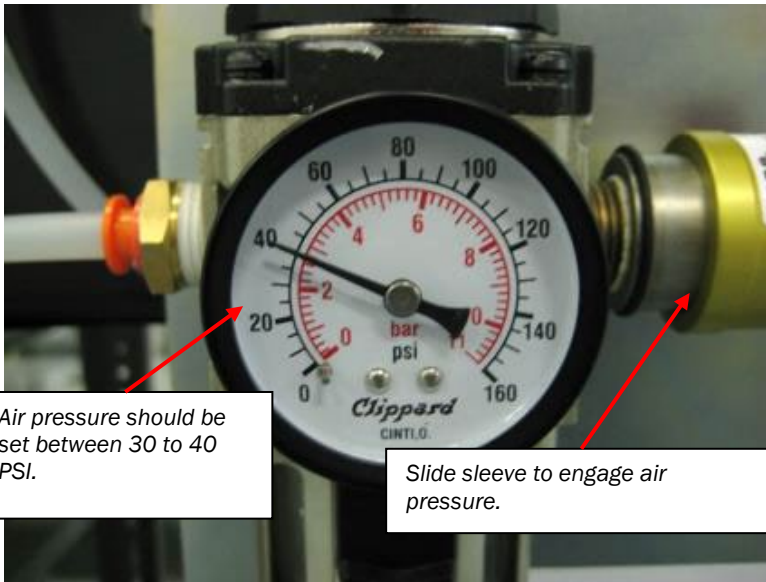

Air pressure should be set between 30 to 40 PSI.

Slide sleeve to engage air pressure.

Primary Conveyor Regulator P/N E0034790

Step 2

Disconnect the power to ALL the logic modules (switch off SICK conveyor mounted power supplies). All logic modules lights should be OFF. This will depress the springs in the pressure pan creating a belt path.



All logic modules lights should be OFF.

Step 3

Remove bottom guard on drive to have access for belt threading the 500-AT bottom guard is a flat plate.



Step 4

Uncoil the new belt. With the air pressure **ON** the logic, and the logic module power **OFF**, attach a sheet metal splint or the belt threading tool (attached to each drive from factory P/N 1118104) with tape to the end of the belt. This will enhance the ability to thread the belt under the rollers without the ends curling.



NOTE:

Keep tape smooth and do not apply too much tape, as it will make it difficult to push the belt through the guide rollers.

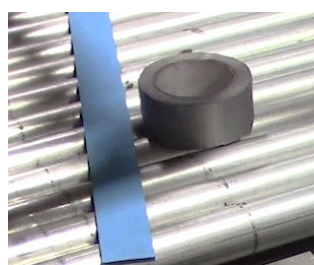

NOTE:**a) If replacing an existing belt.**

If replacing a belt determine if the old belt can be pulled through the conveyor. If yes the threading tool will not be needed. Make sure belt path is free from debris.

Duct tape the top and bottom of the old belt end to the new Nitta belt end (thick polyurethane side up) making sure to keep both belts flat and straight, **do not overlap the belts**.

Pull the new Nitta belt through the conveyor. Make sure the Nitta belt is **routed correctly** over all the return pulleys underneath the conveyor (**Always** reference the belt path label on the side of the drive and pull the belt through.). Remove the Duct tape.

Before cutting the belt to length, make sure there is 18" overlap for NBC 150-AT & 250-AT30 for NBC 500-AT 36" overlap is required. The overlap is to compensate for belt loss in the finger splice process. Both belt ends must be cut straight.



Tape ends of belts.

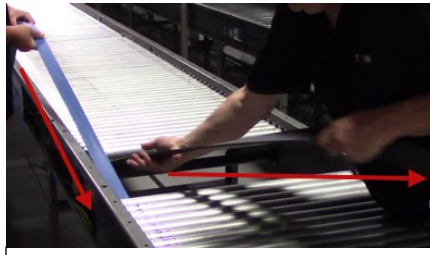

Pull Nitta belt through NBC conveyor.

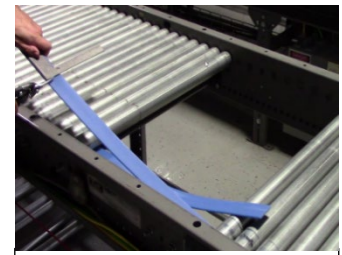

Overlap belt ends.

b) Nitta belt welding instruction

MHS Conveyor Nitta Belt Weld Instruction Manual #1120515 – mhs-conveyor.com

MHS Conveyor Nitta Belt Weld Instruction Maintenance Video – mhs-conveyor.com

Step 5

Remove rollers at each end and insert the splint with belt attached. Push belt into conveyor. It will be necessary to remove sections of rollers every 30' or 40' to help pull / push the belt through.

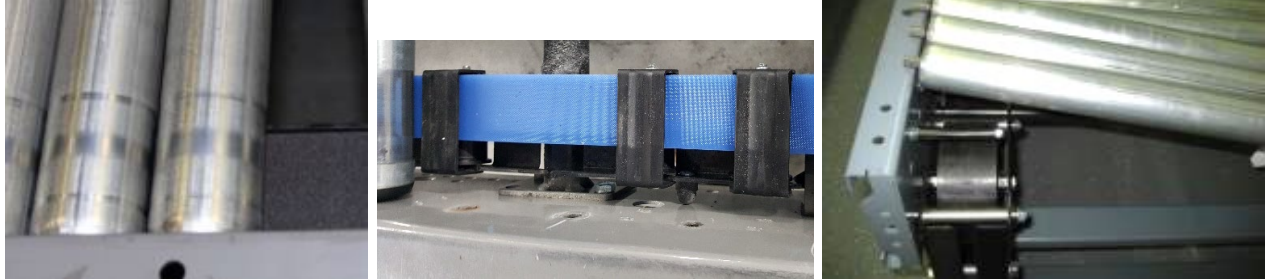

Step 6

Remove bottom guard for end pulley.

Push belt down between the stationary spacer and 6" dia. end pulley, and up and over the 6" flanged snubber pulley.

Make sure belt passes between ball bearing belt guides and end pulley.



Step 7

Pull belt through the bottom side of the conveyor. The belt must be on TOP of the return belt idlers. Wrap the belt end around the drive take-up pulley. Wrap the belt end around the drive idler pulley before the air take-up pulley in AT drives.



Step 8

Always reference the belt path label on the side of the drive and pull the belt through.

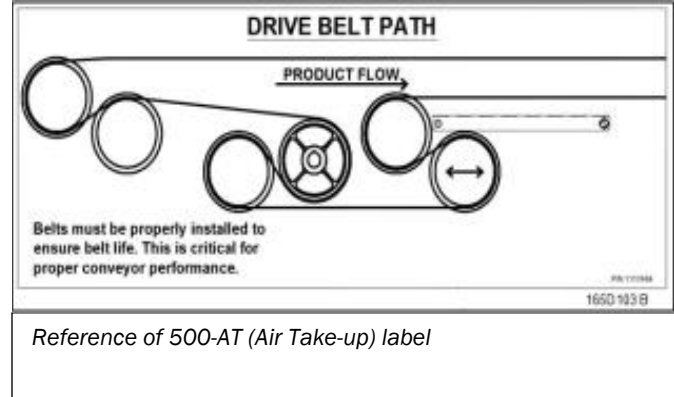
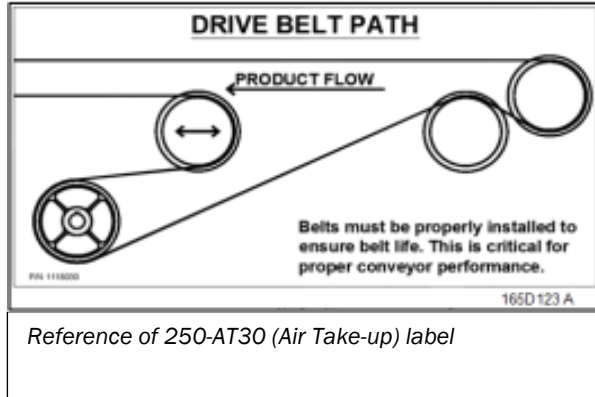

CAUTION

- Never field splice the blue urethane belt (MHS Conveyor P/N 1205548) with mechanical lacing, as the belt fabric is not designed to hold lacing.

For more NBC applications MHS Conveyor recommends the following IOM's at: mhs-conveyor.com

MHS Conveyor Also recommends NBC maintenance videos for tracking the NBC belt and NBC belt alignment at: mhs-conveyor.com

9.1 THREADING BELT IN NBC TRANSPORTATION CONVEYOR

Step 1

NBC transportation conveyor is spring to drive with no air. To open a belt path, two Cams under each pressure pan must be rotated to the high side of the Cam.

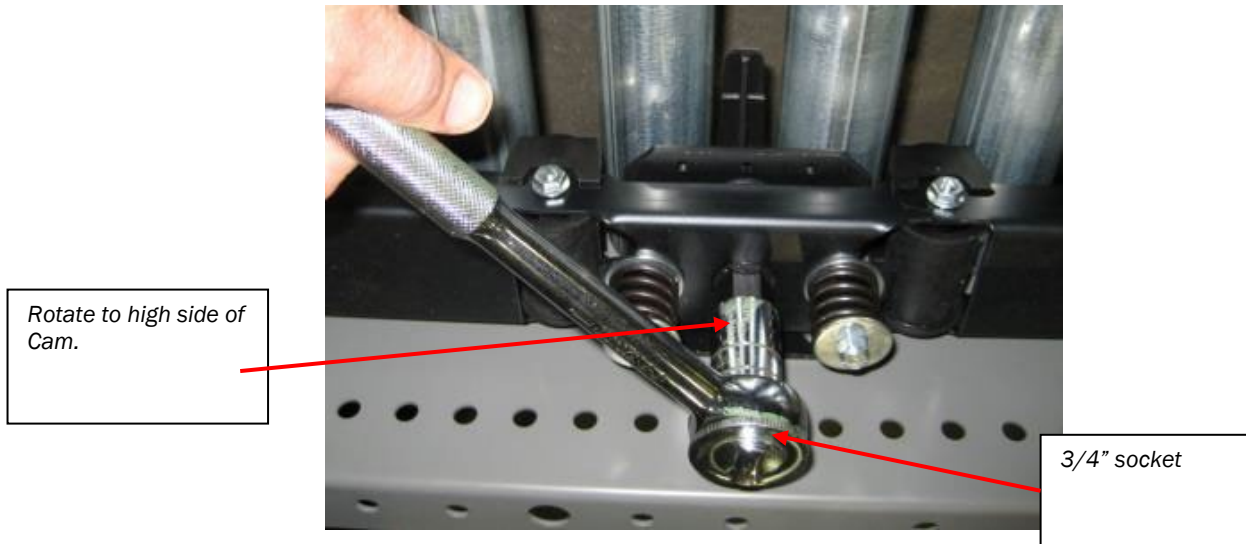

Step 2

Thread the belt as shown in steps 3 through 8 of the NBC accumulation conveyor.

Step 3

Rotate each Cam back to the low side of the Cam re-engaging the spring.

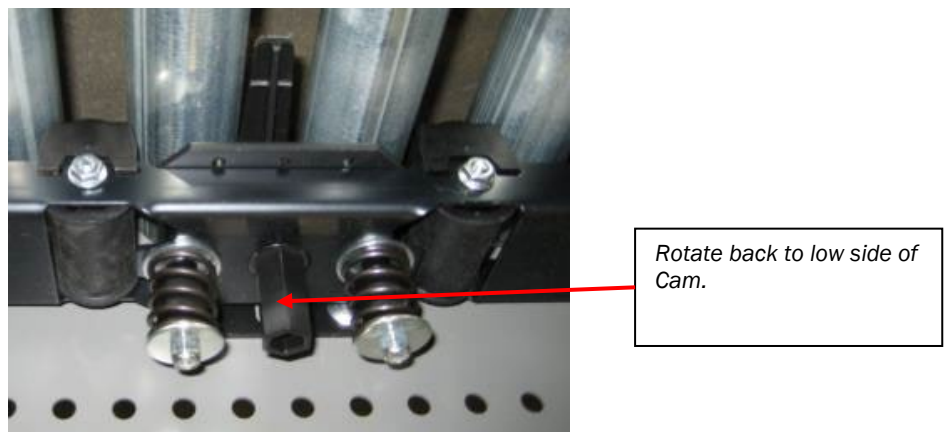

Form more NBC applications MHS Conveyor recommends the following IOM's at: mhs-conveyor.com

MHS Conveyor Also recommends NBC maintenance videos for tracking the NBC belt and NBC belt alignment at: mhs-conveyor.com

10 NBC AIR TAKE-UP

10.1 500 LB.-AT DRIVE TENSIONING (AIR TAKE-UP)

Step 1

With primary air pressure on and belt installed, slide air shutoff switch forward to engage the air tension on the belt (shown). The belt tension will automatically adjust.

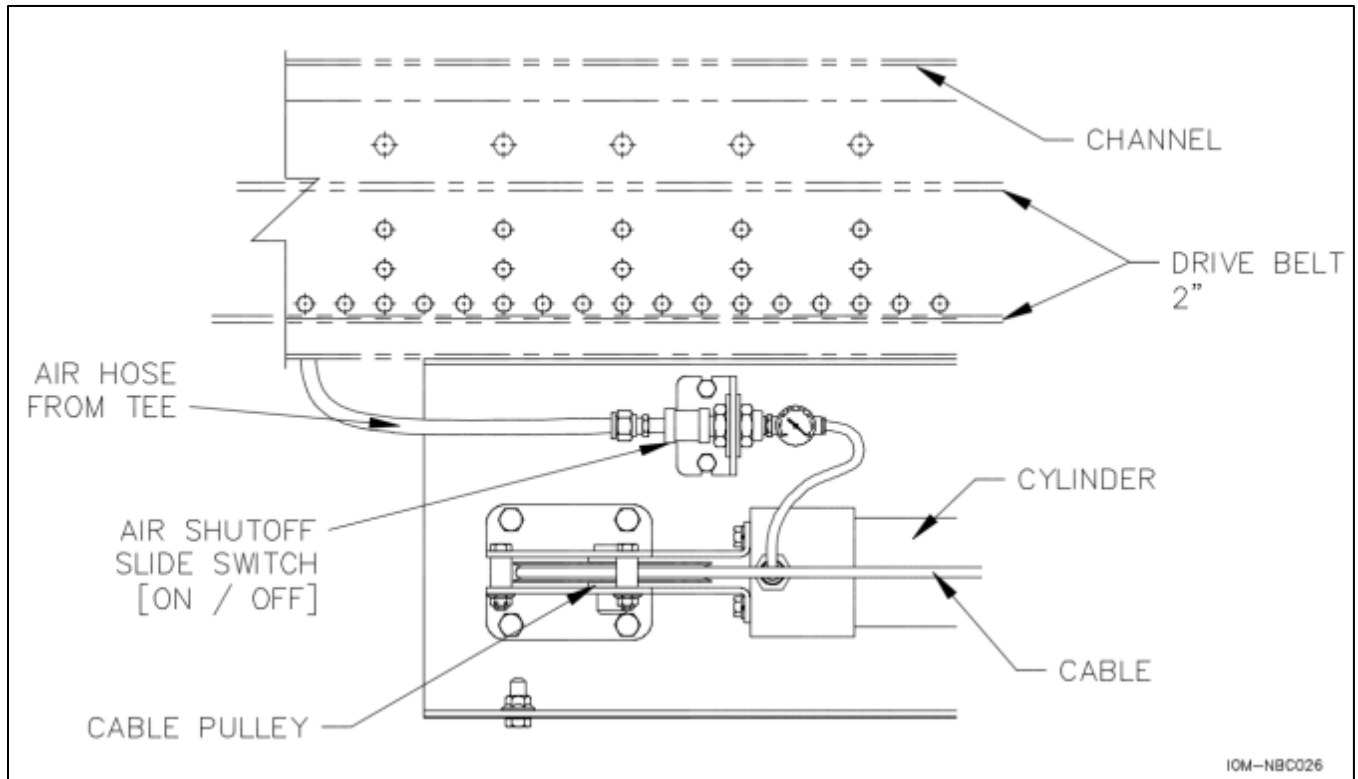

500 LB.-AT Air sleeve valve assembly.

10.1.1 Wiring (Optional) Proximity Switch - 500-AT Drive Air Take-up

There is a location for wiring a proximity switch in the air take-up. This can be used to shut off the drive should the belt stretch to the point of bottoming out the take-up or if a belt would break.

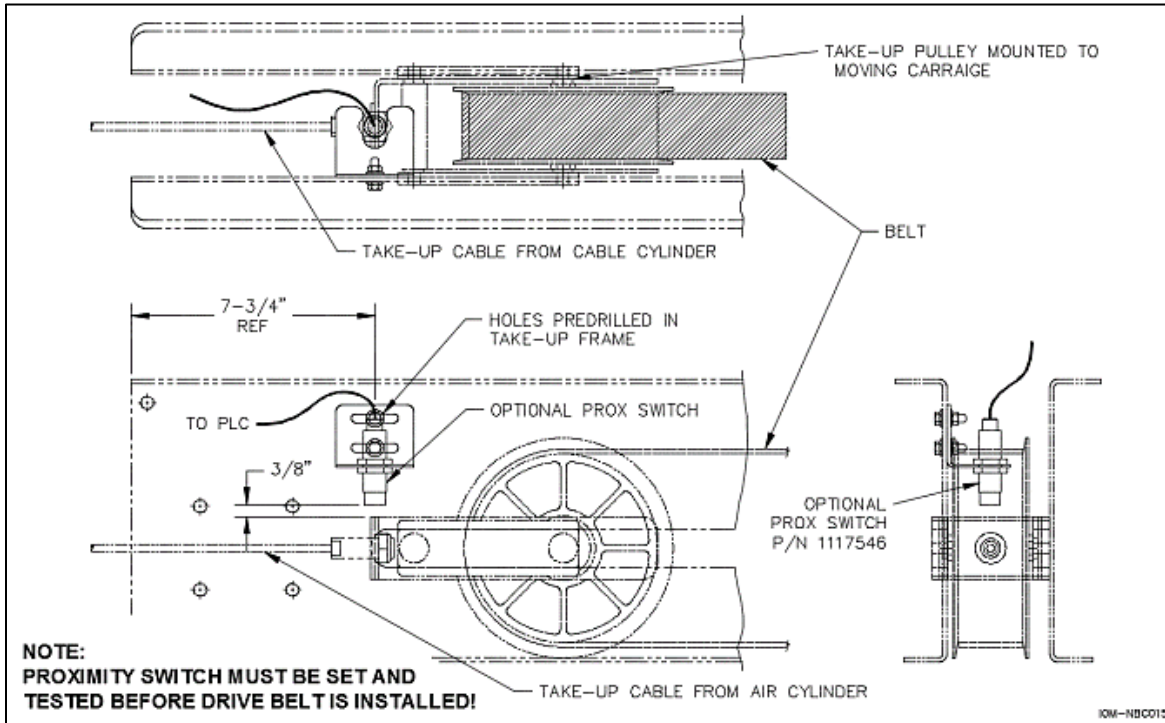

Drawing view of optional proximity switch for 500-AT Drive air take-up.

10.2 NBC CROSS SECTIONS

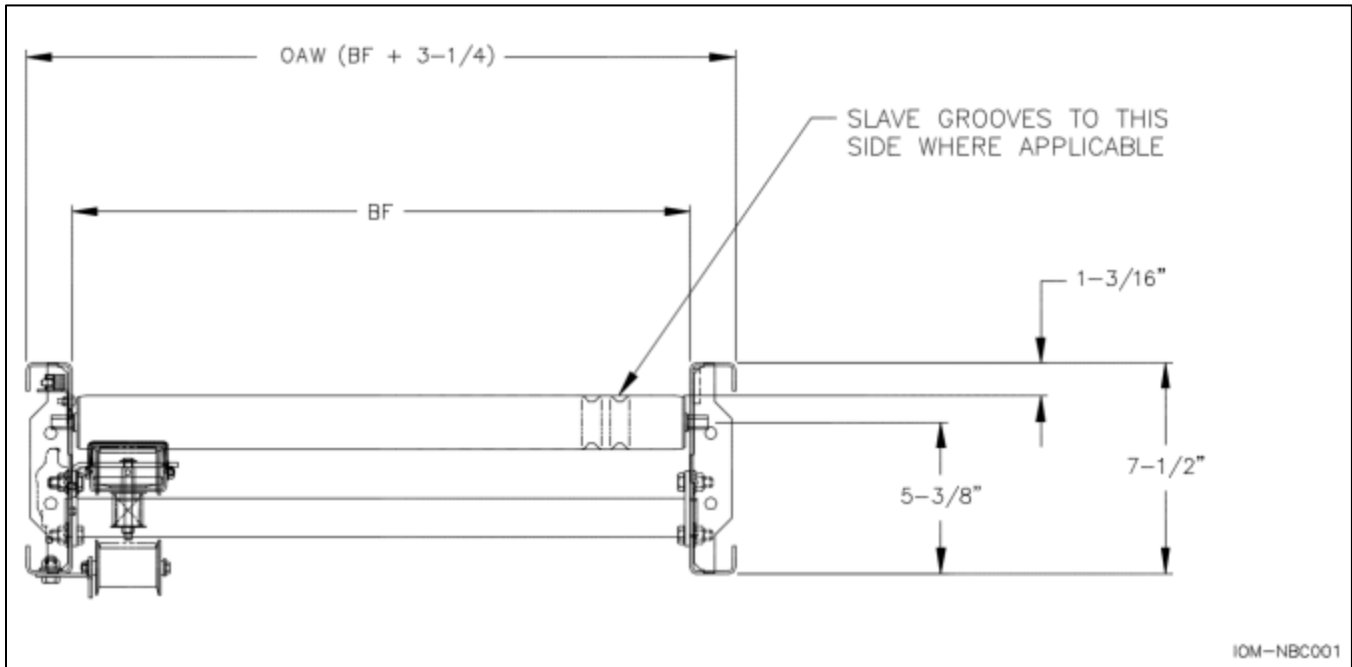

NBC accumulation with CRUZchannel rollers low

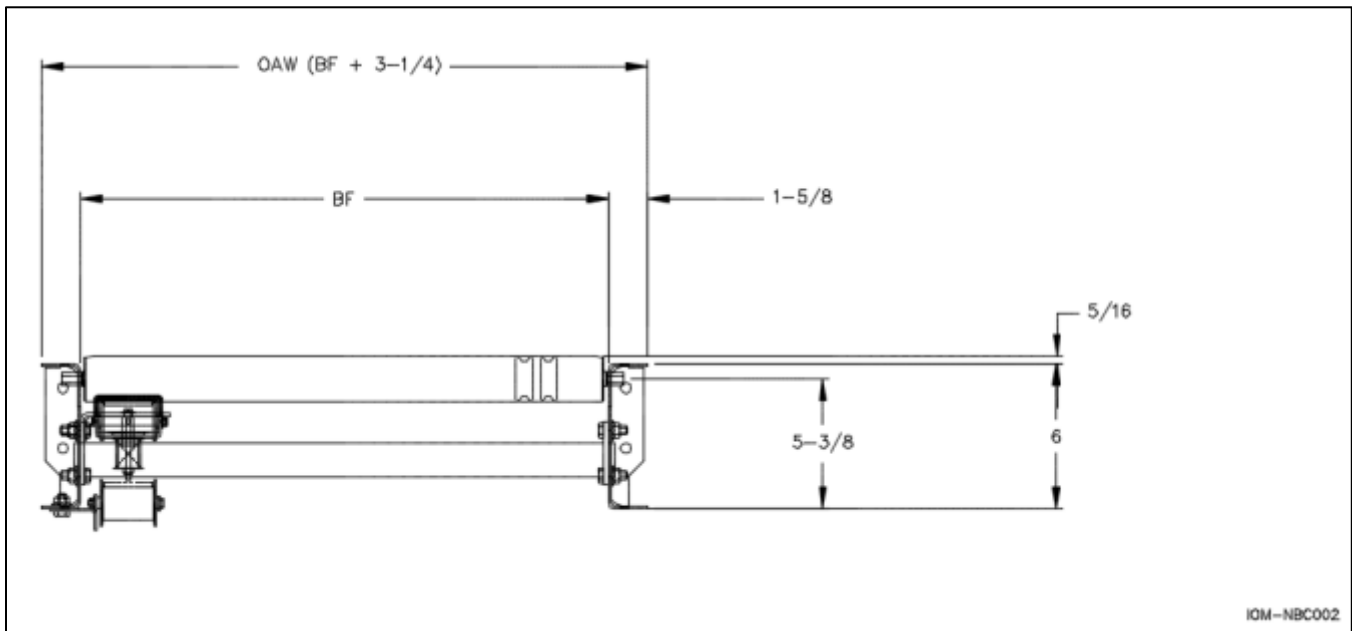

NBC transportation with C6 channel rollers high

11 NBC SKEWING NBC ROLLERS

Skewing rollers is required on NBC if you are using contact accumulation and if the between frame (BF) dimension of your conveyor is double the width of the smallest product. The normal method of skewing is to install a factory skew bed at the charge end of your conveyor. If your conveyor line is over 100' long and you have small product on it, you may want to add a maintenance skew bed midway down the conveyor to preserve the product alignment.

11.1 FACTORY SKEW CHARGE SECTION

A standard 12' charge end skew bed is available with factory skewed rollers at 7 degrees. This bed is available in left or right hand. The wheel guard rail is included. This skewed bed will move products across the conveyor about 16" over the 12' length. This side movement is dependent on the bottom condition of the product.

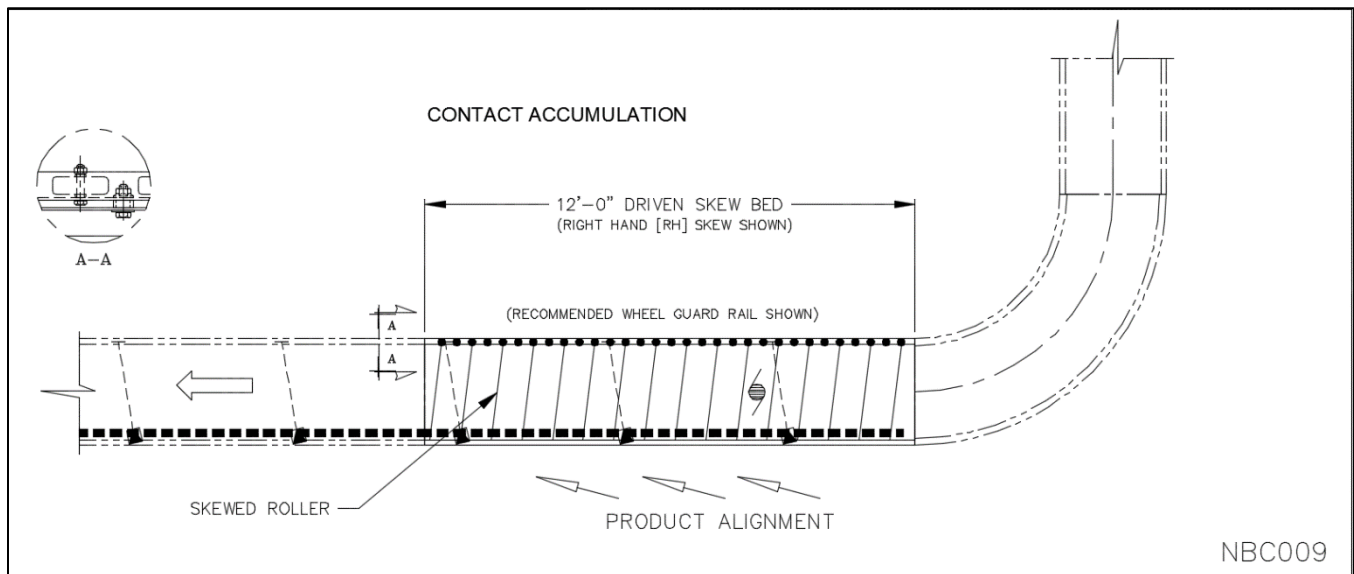

Standard 12' charge end skew bed

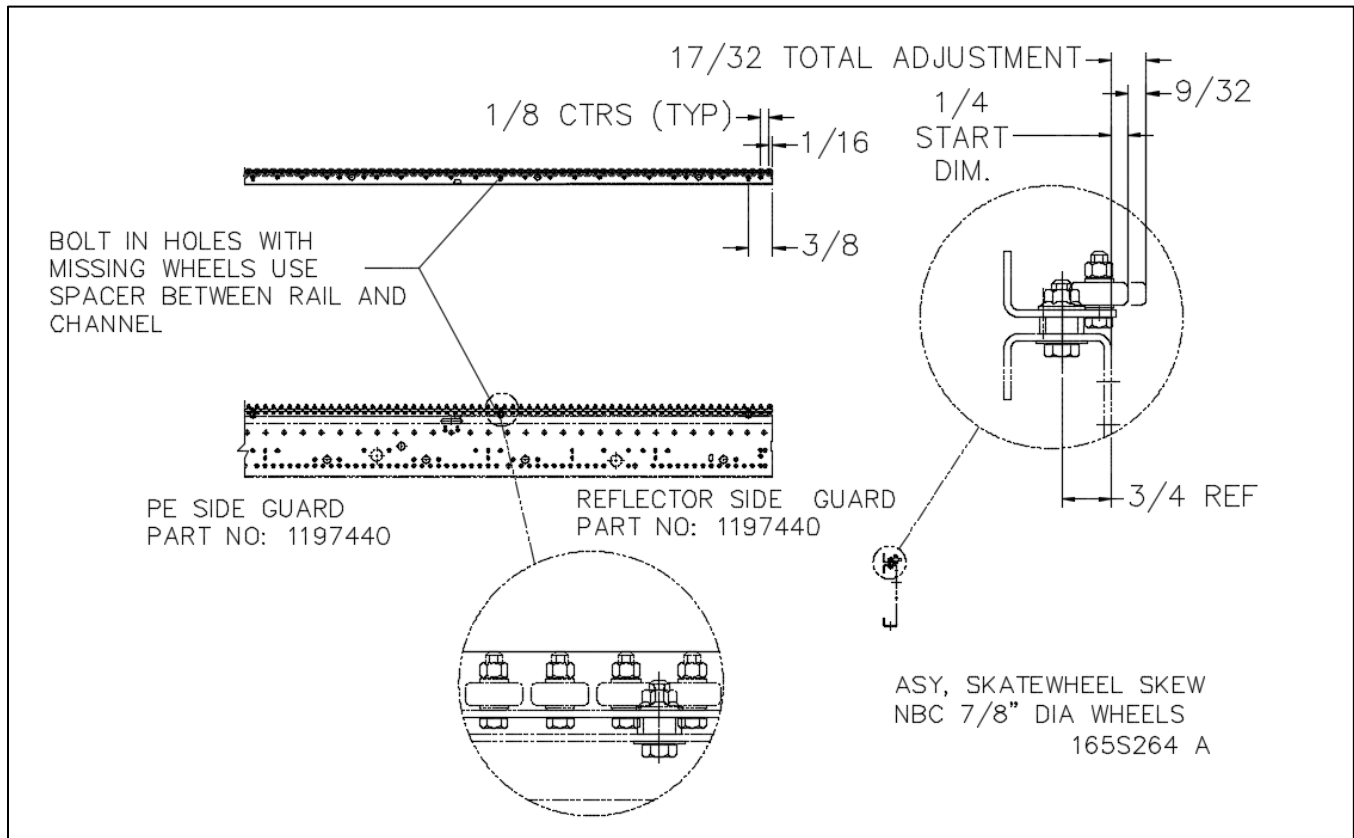

Drawing of NBC wheeled guardrail.

NBC 12' Skew Bed Installation

MHS Conveyor' dedicated 12' skew bed typically is installed as the first 12' bed section in an NBC conveyor line, starting from the charge end. The rollers are factory skewed to the requested side and the installation is the same as any other NBC intermediate bed section.

A 12' wheeled guardrail is included to prevent the stalling of product as it is forced against the side channel by the skewed rollers. The wheeled guardrail is shipped loose and must be field installed. To install, line up the bolt holes on the guard with the holes in the top flange of the 12' skew bed side channel. The end of the guard and the end of the conveyor bed should be in line.



NBC Wheeled guardrail.

11.2 MAINTENANCE SKEW SECTION

Other than the charge end skew bed, all standard 12' beds have a 4' skew zone designed for the center of the bed. Hole punching in the side channel allow for a $\frac{3}{4}$ " offset of the rollers over the width of the bed.

NOTE that this means wider beds have less of a skew angle than narrow beds and produce a less aggressive skew. **About 2" of movement across the conveyor can be expected per 4' maintenance skew zone on 16" BF conveyor, and 1" of movement on 34" BF conveyor.** A sticker on the conveyor side frame indicates the 4' skew area.

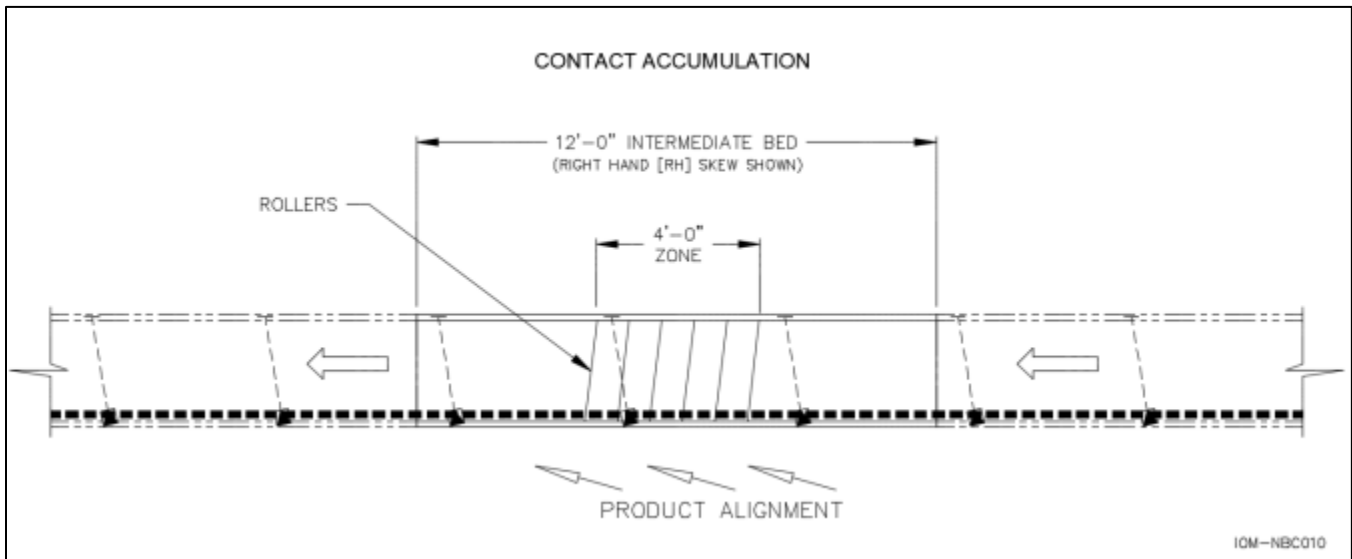

Drawing of product alignment maintenance skew zone.

Maintenance skew beds are typically used in contact accumulation NBC lines over 80' which have small product on them. After initial alignment by a charge skew bed, maintenance skew beds keep products aligned. If an NBC conveyor requires maintenance skewing after installation, field skewing of the middle section of a 12' bed is possible. The required skew pressure pan is already included in the middle zone of the standard 12' bed. If product contacts the side channel, a wheel rail should be used.

The steps for field skewing these zones are listed on the following page.

CAUTION

- Never skew rollers without a skew pressure pan installed. Belt damage will result and warranty will be voided.
- Do not over skew rollers, as it will cause premature belt failure.

11.3 FINGER GUARDS FOR SKEWED MAINTENANCE PRESSURE ASSEMBLIES

NOTE:

The skew guard is attached to the lower conveyor side channel located on the inside face of the channel on the opposite side of the belt.



Skew bed skew guard storage location.

11.4 ROLLER CENTERS 2”

Step 1

Select the conveyor section in which the rollers are to be skewed. Determine the direction of skew desired and remove one roller from discharge end of the center zone.



NOTE:

The bed 4' center zone is the only zone that can be skewed on a 12' intermediate bed.

Step 2

Install belt guard in 9/32" dia. hole provided. Belt guard provides support of small product at the formation of the skewed zone.



Note:

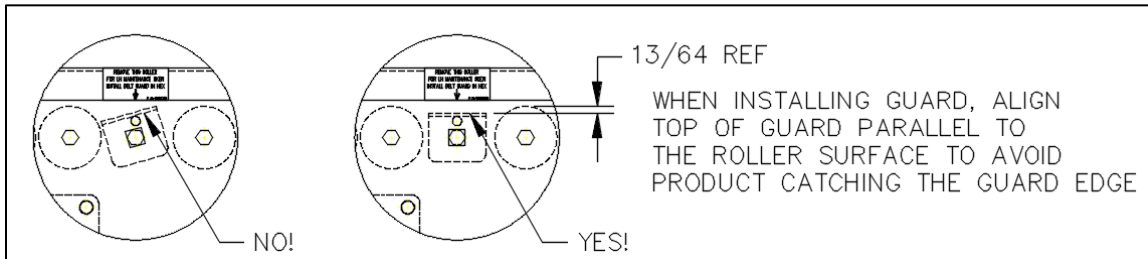

Step 3

Skew rollers 3/4" to direct the product to the alignment side.

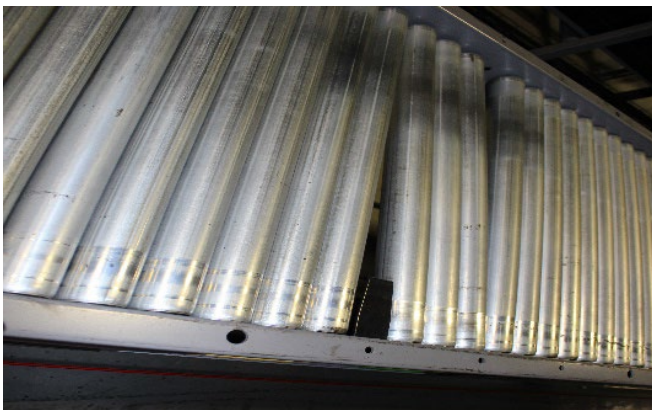

Right Hand Skew Shown Traveling from Right to Left

NOTE:

Rollers may only be skewed a maximum of 3/4" in either direction. One hex hole either side of three-hole groups on 3" roller centers.

11.5 ROLLER CENTERS 3”

Step 1

Select the conveyor section in which the rollers are to be skewed. Determine the direction of skew desired. All rollers in the middle zone are used for skewing.

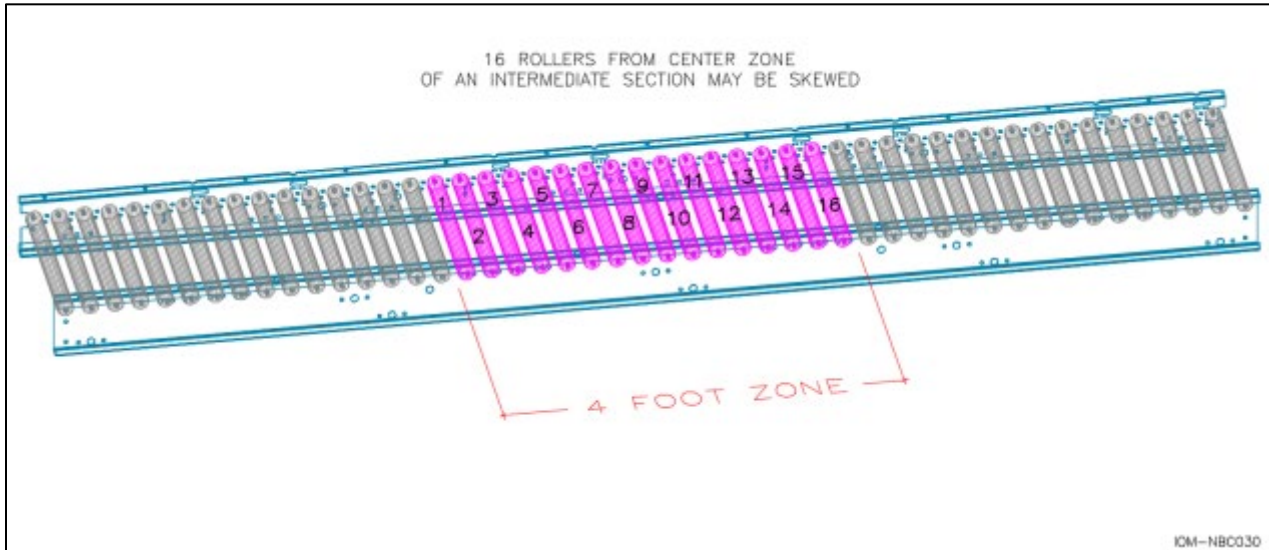

NOTE:

The bed center 4' zone is the only zone that can be skewed on a 12' intermediate bed.

Step 2

Skew rollers $3/4$ " to direct the product to the alignment side.

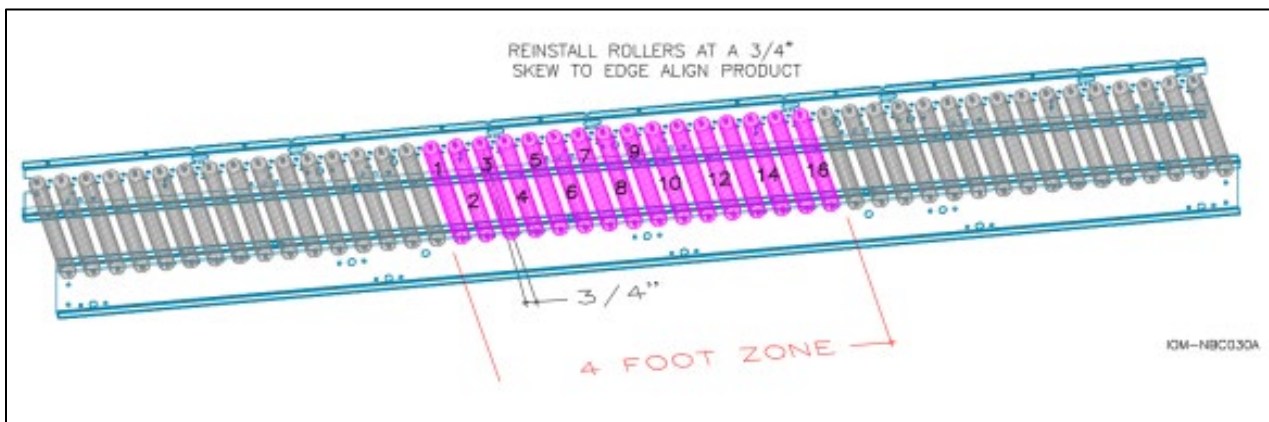

NOTE:

Rollers may only be skewed a maximum of $3/4$ " in either direction on the side channel opposite the drive belt.

11.6 CRUZ® CHANNEL TO XENOROL® CHANNEL CONNECTIONS

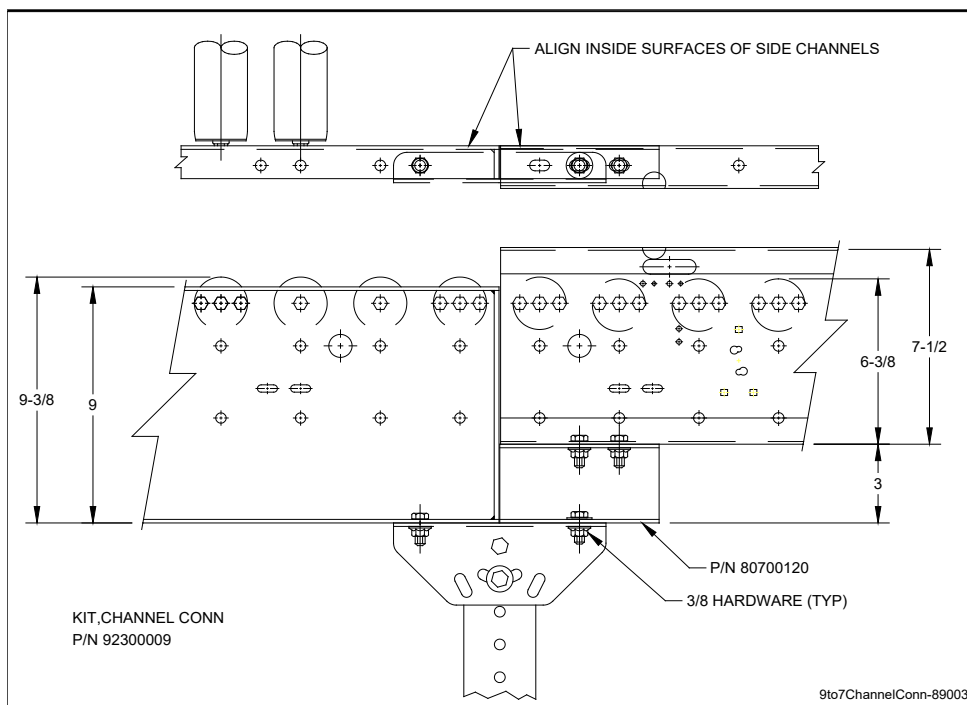
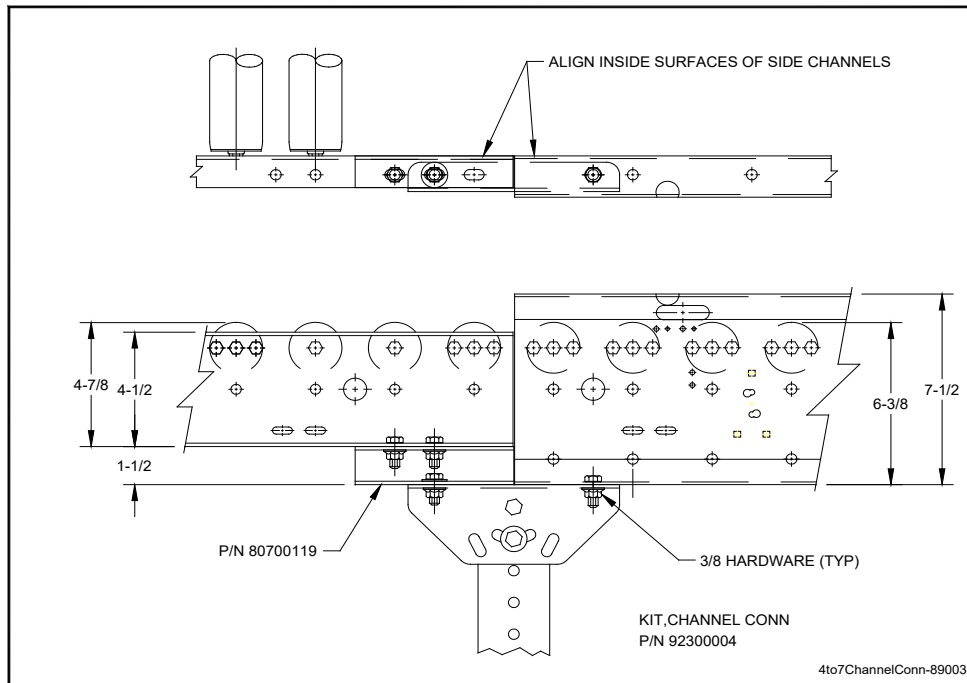

NOTE: C6 Channel uses the exact same connections when mounted to XenorOL.

11.7 GUARDRAIL MOUNTING ON NBC

NBC can be supplied with rollers low which uses the CRUZ side channel 1 ½" high guardrail. If C6 channel is supplied, any of several height angle guardrail can be used.

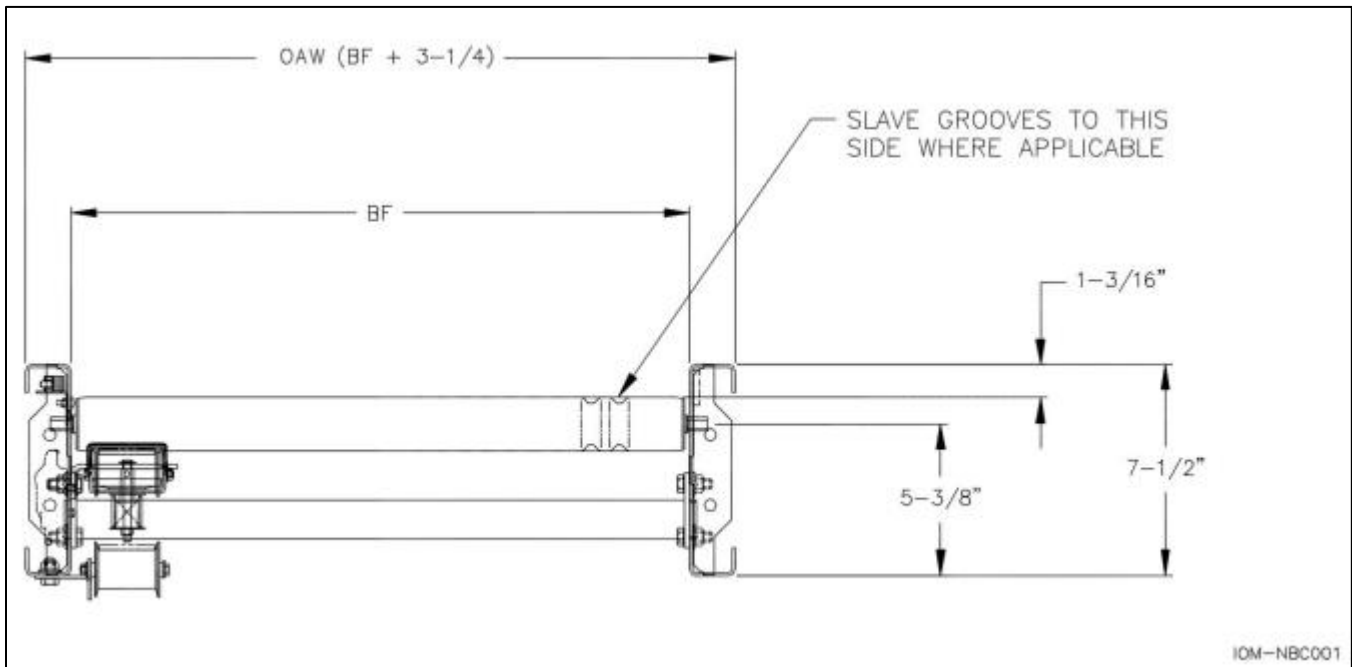

CRUZchannel side frame acts as a guardrail

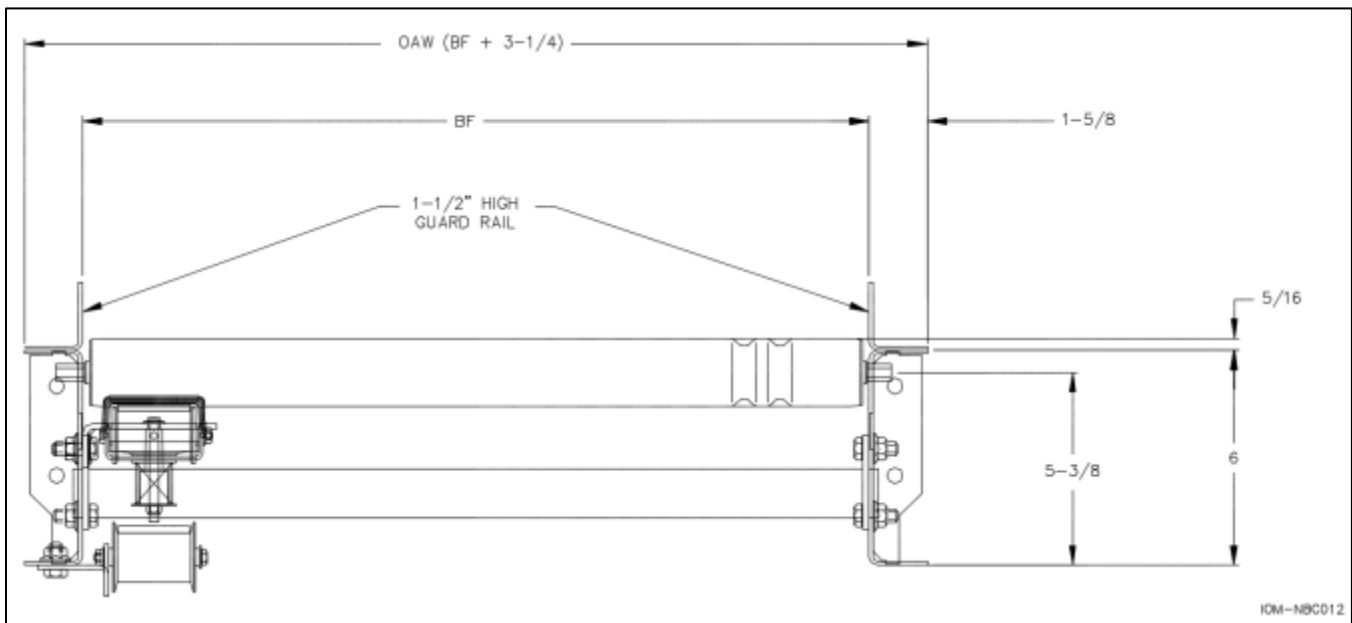

Use 1-1/2" angle for C6 channel guardrail.

Use any of several height angle guardrails on C6 channel depending on photoeye placement, and conveyor usage.

For all elevations requiring high guardrail, the NBC is designed to use adjustable guardrail. The configurations and associated part numbers are shown below.

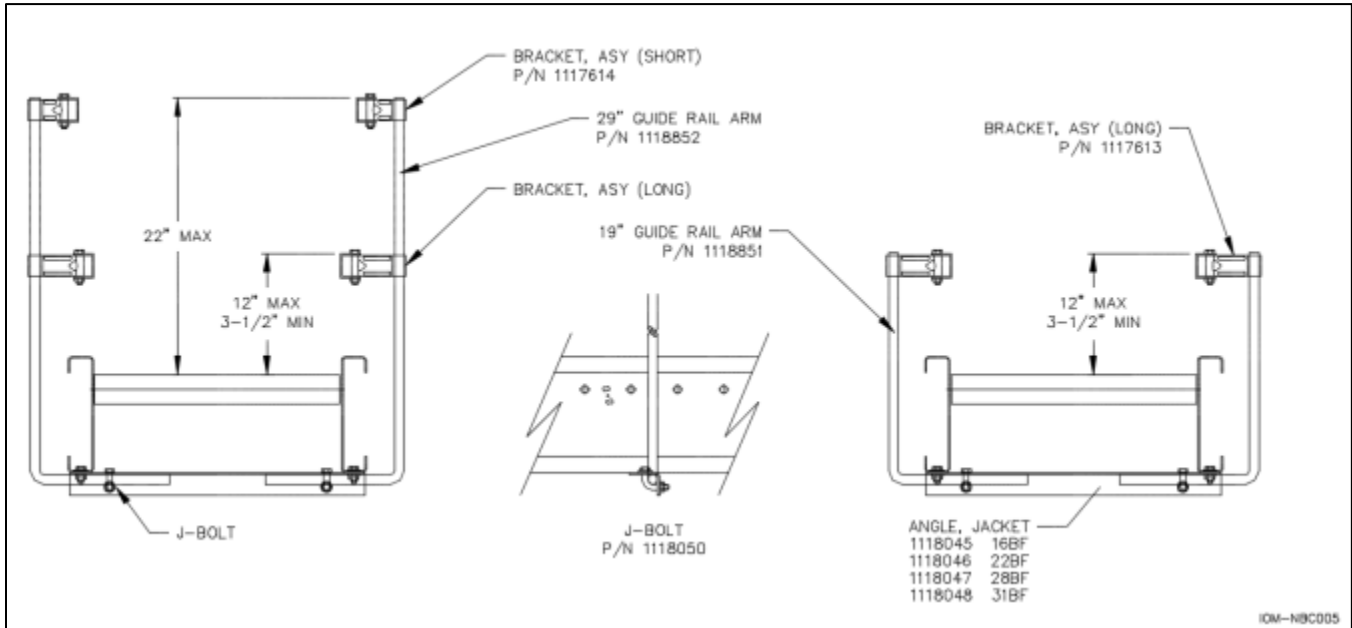

Adjustable guard single high and double high

Flared lead-in section for adjustable channel guardrail.

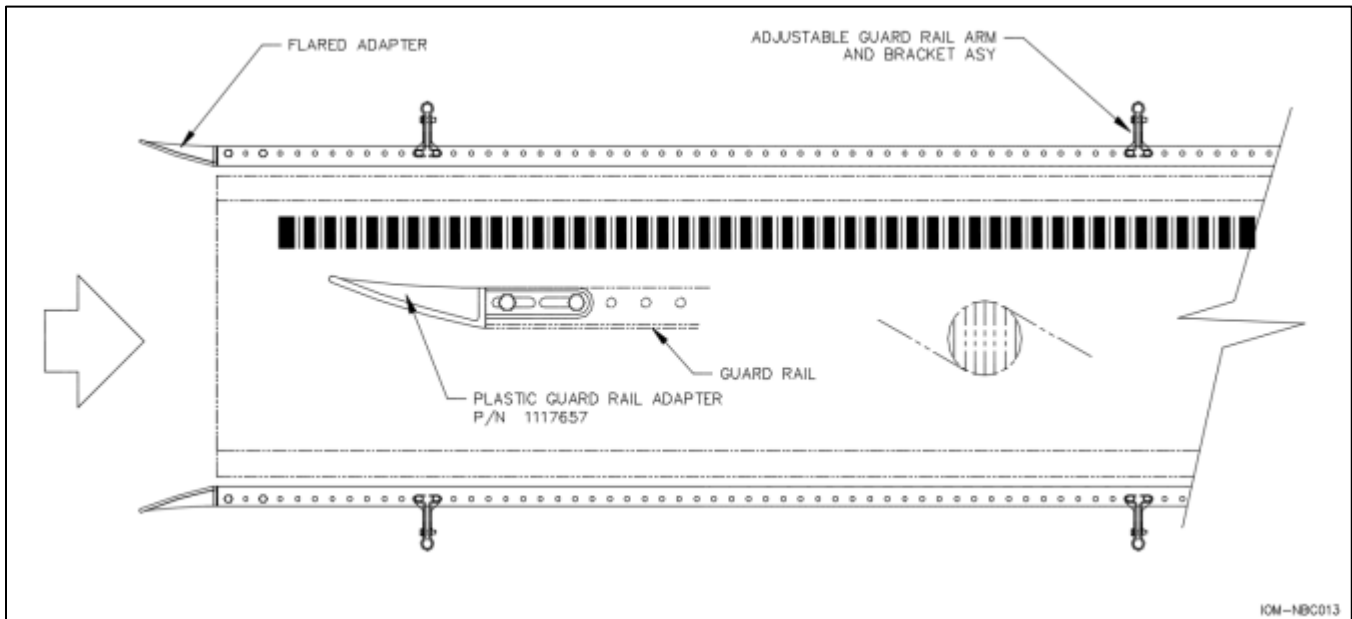

Use part #117657 at the entrance of all adjustable channel guardrail.

11.8 CRUZCHANNEL TO C6 NOSE PIECE

A CRUZchannel to C6 nosepiece provides a smooth transition for products moving from rollers high conveyor to rollers low conveyor.



12 NBC AIR SUPPLY REQUIREMENTS

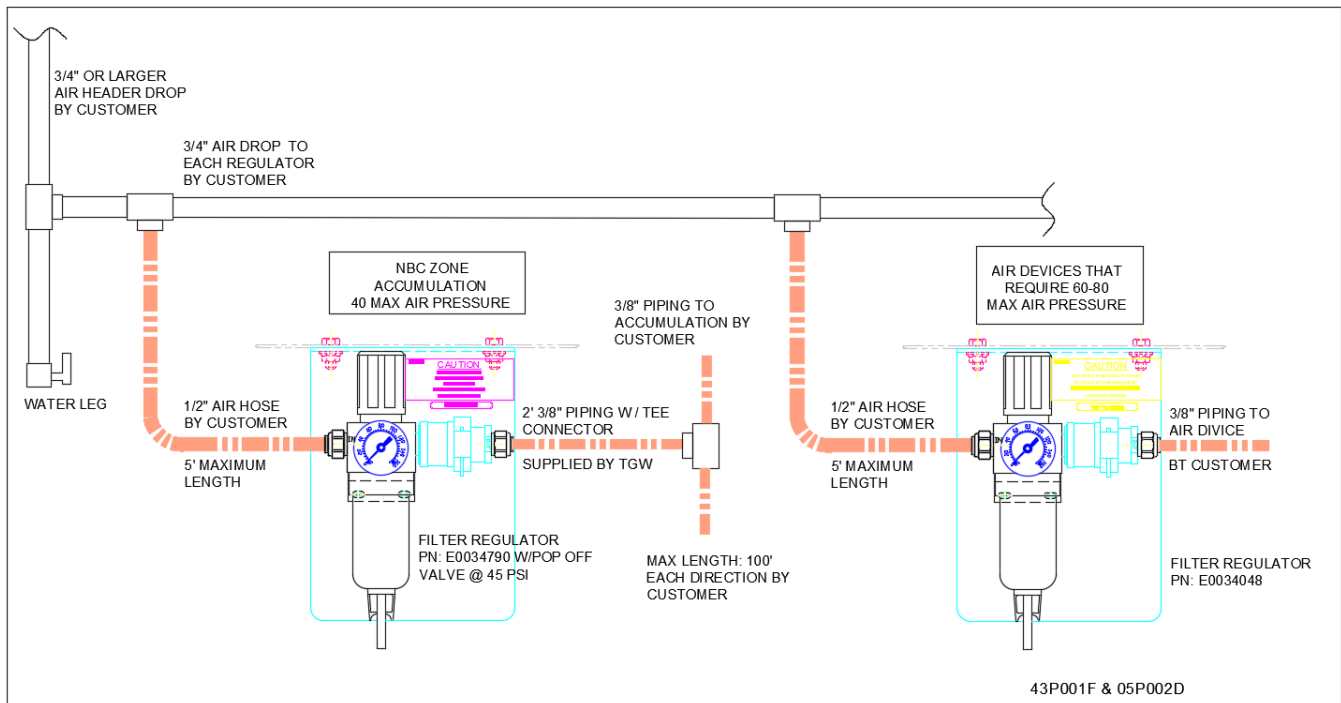

General

Every conveyor system is unique, with its own specific requirements. Therefore, the following is a general guide.

Main Feeder

Air velocity through the main feeder piping can be kept smooth with lower losses using large diameter pipe with minimum bends and restrictions. Standard weight black pipe or copper is suitable for plumbing the compressed air overhead to all points of use.

Air Drops

MHS Conveyor recommends using at least 3/4" pipe on air drops for high flow and low-pressure loss. The drop is terminated with a drain at the bottom. A tee located prior to the drain branches off to the conveyor. This branch line must contain a lockout/shutoff. A shutoff must also be located in the drop before the branch tee. OSHA Rule 29, CFR1910.147 <https://www.osha.gov/> requires energy sources (air drops) be turned off and capable of being locked or labeled with a warning tag.

NOTE:

The pneumatic system for NBC installations does not require lubrication. Lubrication may affect the valve operation and cause sluggish or erratic operation.

Air drop is a line dispersed from the plant main air header feed.

CAUTION

- All factory airlines must be thoroughly blown out to clear all debris.
- The regulator must be set at 40 PSI prior to connecting air to NBC.
- If your air compressor uses synthetic oil, a coalescing filter plus a regular filter of 5 micron is required.
- Synthetic oils will shrink the seals in pneumatic devices and valving.

Low Pressure Switch

CAUTION

- Loss of conveyor control will occur if air pressure is not maintained.
- A pressure switch is required to be installed into the pneumatic circuit feeding an NBC conveyor system to detect a drop in air pressure below operating limits.
- Conveyor system must be shut-off if low pressure is indicated.

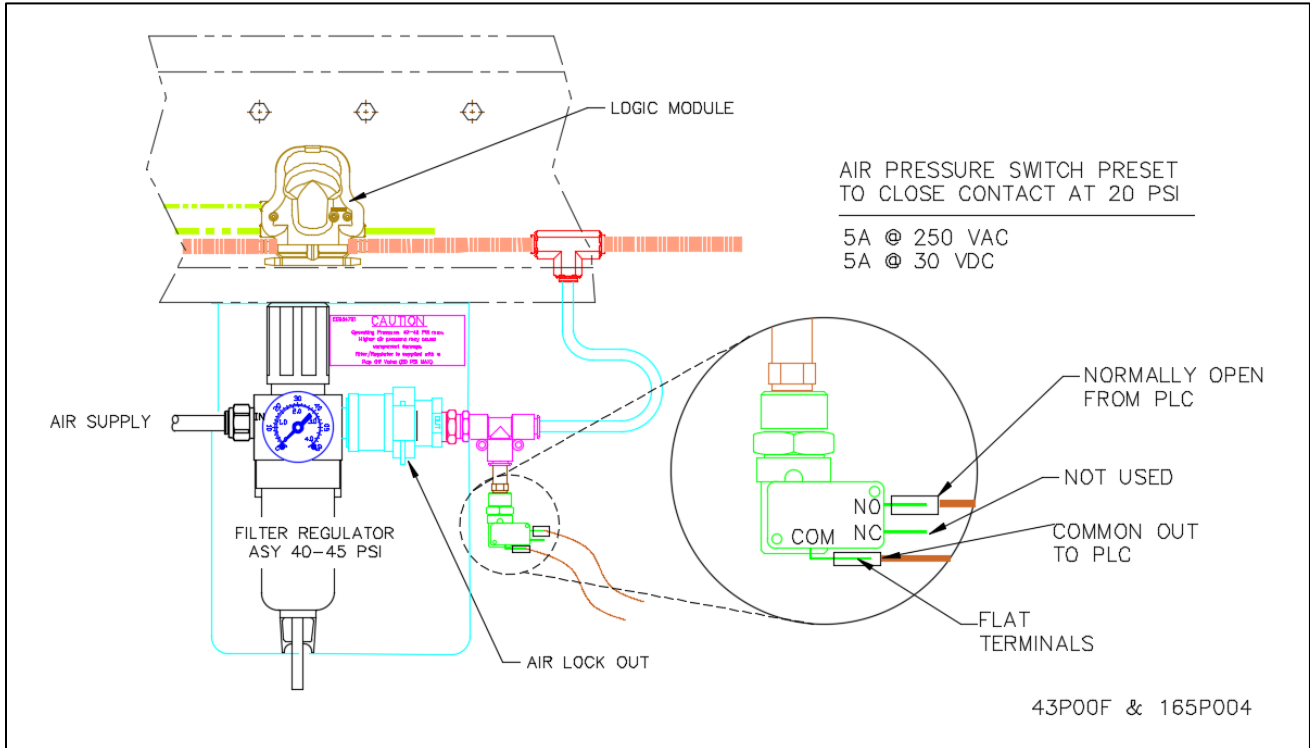

12.1 AIR PRESSURE APPLICATION

1. MHS Conveyor supplied pressure regulator is required. (P/N E0034790) Includes: Pop off valve at 45 PSI.
2. Regulator pressure set at 40 PSI. Pressure over 40 PSI can cause permanent damage to the pneumatic actuators.
3. Maximum conveyor length each way from regulator is 100'.
 - a. Locate the regulator in center of conveyor for minimum air pressure drop.
 - b. Conveyors over 200' require additional regulator.
4. Low pressure switch to be set to indicate a pressure drop below 20 PSI.
5. In high humidity or low temperature, use an air dryer.
6. Use 5-micron filter.
7. Lockout/shutoff valve to be provided by air system installer for factory high pressure line before regulator.
8. Low pressure switch is recommended.

Other:

1. Compressor HP = total CFM ÷ 3.55
2. Air tank size = approx. 1 gallon per CFM

The formulas to determine air consumption follows:



SCFM = .0019 x number of zones x releases per minute for NBC contact accumulation.

12.2 AIR REGULATOR LOCK OUT VALVE ON AND OFF POSITION



NOTE:

- The air regulator valve label details the on and off positions.
- For air pressure regulations please see detailed instruction in this manual.

 WARNING	
	<ul style="list-style-type: none">• Do not remove and install sleeve valve to infeed side of regulator. Back feeding through the regulator will cause damage and void the warranty.

13 NBC LOGIC MODULE CONCEPTS

13.1 CRUZCONTROL® LOGIC

CRUZcontrol is MHS Conveyor accumulation logic package. It utilizes a simple electronic sensor control system providing features that accommodate all accumulation control requirements. This cost-effective logic package is a standard feature of NBC.

It is the intent of MHS Conveyor, through this manual, to provide information that acts as a guide in the installation, operation, and maintenance of MHS Conveyor conveyors featuring CRUZcontrol Logic.

This section of the manual describes basic installation practices, assembly arrangements, preventive maintenance, and assists in replacement parts identification. It is intended for use by personnel who are knowledgeable of installation and safe working practices on conveyor systems.

Not all applications and conditions can be covered; therefore, this information is to be used as a guide only.

CAUTION

- Add a soft start to all NBC conveyors for speed of 180 FPM and above.
- A controlled speed start-up prolongs belt lacing life at all speeds.

CRUZcontrol Logic Module Concepts

The CRUZcontrol product line is a set of off the shelf components used to setup accumulation and discharge on NBC conveyor. It consists of logic modules that detect product which control accumulation, function modules that release product, and 24 VDC power supplies. There are also accessories such as sensors and cables to ease installation and interfacing.

CRUZcontrol is a 24 VDC system that will automatically start accumulation when product reaches the end of an accumulation line. When a release signal is applied to a function module that is installed at the discharge end of an accumulation line, the product will begin to release. Product will continue to release until the signal is removed. The type of accumulation that occurs is based on the mode that the logic assembly has been configured for. The type of product release is based on logic assembly mode and function module setup.

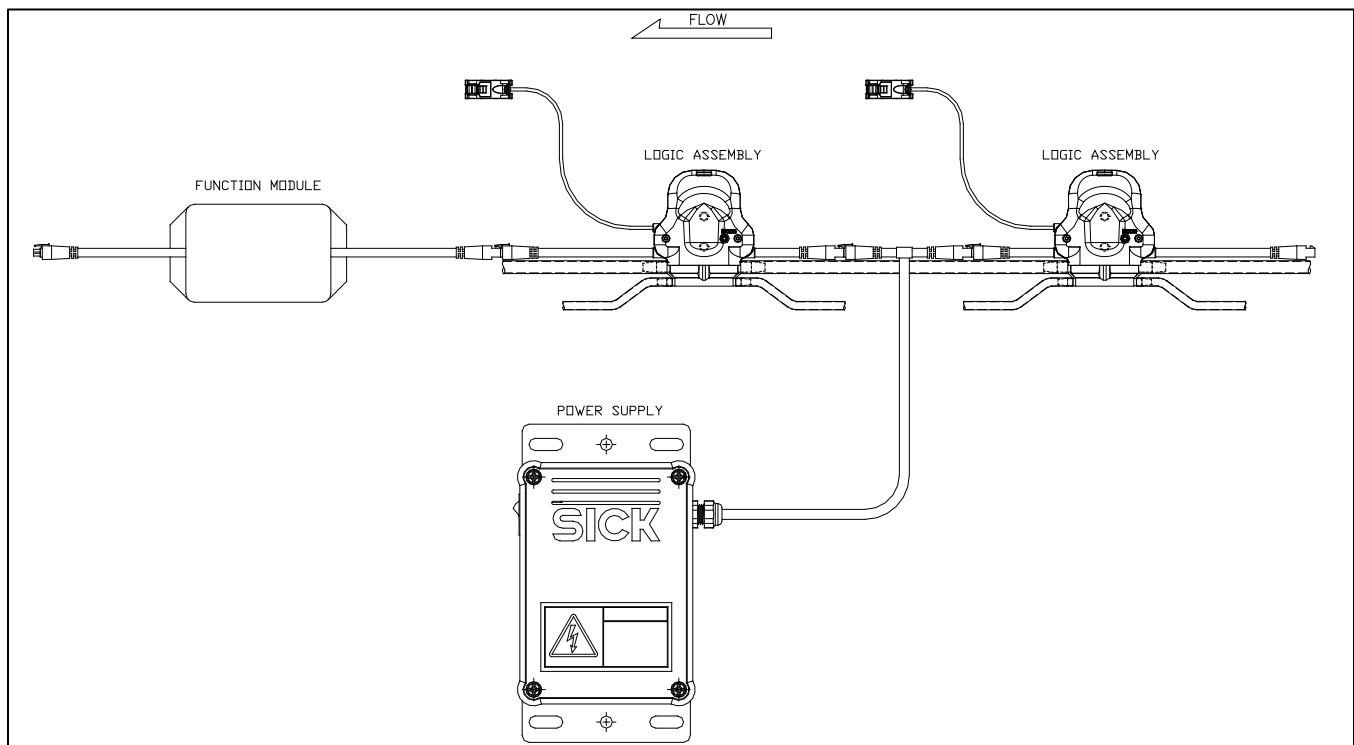

Basic Concept Layout

13.2 SETTING LOGIC MODULES

After mechanical and electrical installation is complete and there is air to the system, the logic modules may need to be reset.

All logic modules are factory set in the basic mode indicated by the green light. This logic mode may be adequate for your conveyor system. However, if higher product throughput is required, some of the basic modules can be switched to progressive is indicated by amber light.

Never switch all the logic modules to progressive. For maximum product throughput, a pattern of 4 progressive modules and 1 basic module should be followed. See Index heading “Basic and Progressive Logic” for additional explanation.



Switching logic modes with paper clip

CAUTION

- Excessing the 4 to 1 logic rule will cause damage to the belt and void warranty

13.3 BASIC AND PROGRESSIVE LOGIC

Every NBC accumulation conveyor is equipped with logic modules that can be switched from basic to progressive logic with a manually activated toggle switch. A green light indicates basic mode and an amber light progressive mode.

The manner in which basic and progressive logic modes change accumulation and release are explained in the following pages.



Green light indicates basic mode.



Amber light indicates progressive mode.
Toggle Switch (use paper clip to change)

13.3.1 Basic Logic Operation

Basic Logic functions such that when any two successive photoelectric sensors are blocked, the upstream zone is set to accumulate (stop driving).

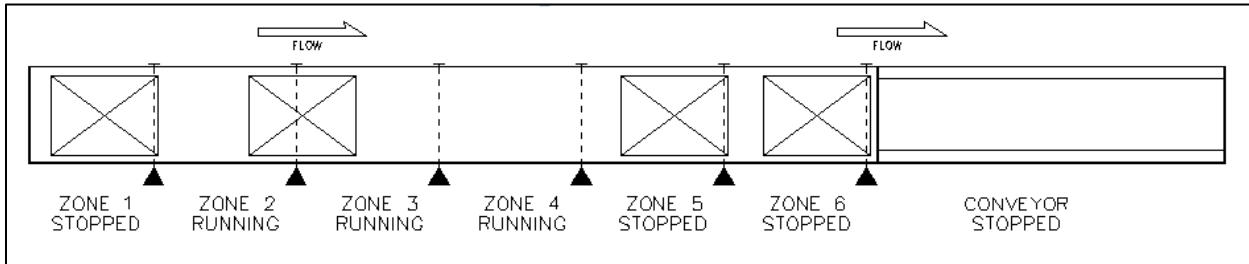

In the above example:

- The discharge zone, Zone 6, is shown stopped, signifying that release from the zone is being inhibited and the Zone 6 sensor is blocked.
- When the Zone 6 sensor AND the Zone 5 sensor is blocked Zone 5 will stop running.
- Zone 4 and Zone 3 sensors are not blocked, and the zones are running.
- Zone 2 sensor is blocked, but the zone is running because the Zone 3 sensor is NOT blocked.
- Zone 1 is not driving because both Zone 1 AND Zone 2 sensors are blocked.

NOTE:

(Basic Logic) Products being transported on accumulation conveyor are separated by a gap of one zone length upon release. This will reduce the transportation throughput capacity of the conveyor. The rate at which product is introduced onto an accumulation conveyor of this type must not exceed the transportation rate of the conveyor.

13.3.2 Discharge from Basic Logic

A release signal given to the Zone 6 Logic Assembly releases product from that zone. As released product clears the electronic sensor, the product stopped at the next upstream zone is driven forward.

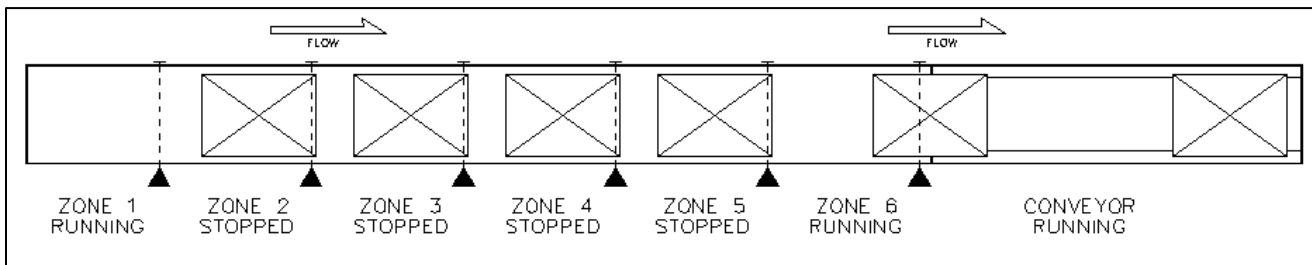

This will create a one-zone length gap between all released products; assuming conveyor speeds (accumulation conveyor and downstream conveyor) are identical.

NOTE:

If the accumulation logic is set to Slug Release instead of Singulation Release, all affected zones will run, resulting in the release of product with little or no gaps. This overrides the normal Basic Logic function.

13.3.3 Progressive Logic Operation

Progressive accumulation functions such that no zones are set to accumulate unless ALL the downstream electronic sensors are blocked, meaning that all downstream zones hold accumulated product.

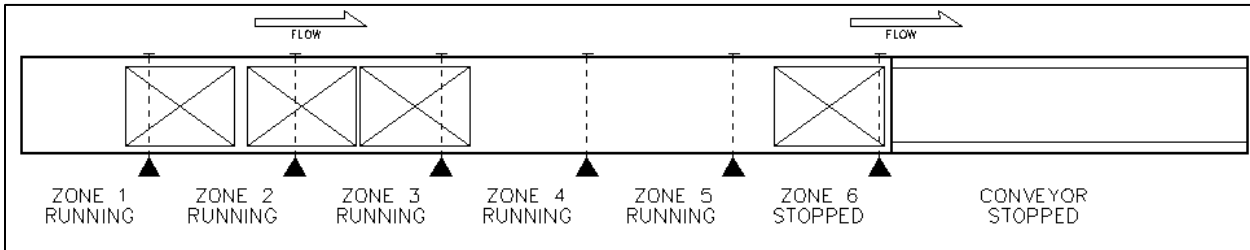

In the above example, the discharge zone, Zone 6, is shown stopped which is the result of the release from the zone being inhibited (receiving conveyor is stopped) and the Zone 6 sensor being blocked.

Zone 5 sensor not being blocked results in all upstream zones, Zone 1 through Zone 5, running.

NOTE:

(Progressive Logic) Products being transported on accumulation conveyor can remain tightly packed, without any gaps being created. The transportation throughput capacity of the conveyor is not reduced due to zoned accumulation.

13.3.4 Discharge from Progressive Logic

When the discharge zone, Zone 6, is provided a release signal, all upstream zones also release.

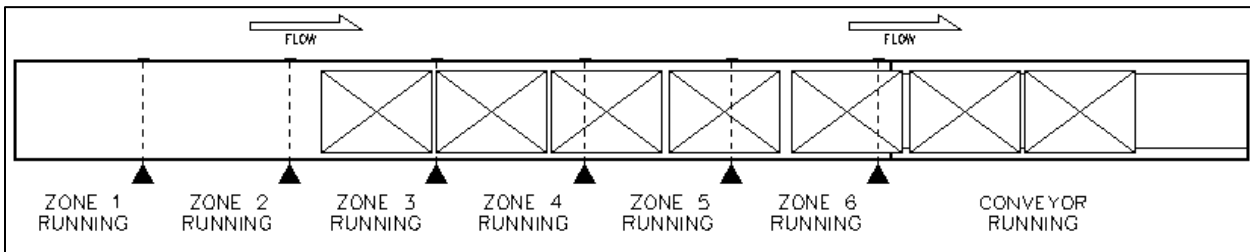

There is no gap between released products; assuming conveyor speeds (accumulation conveyor and downstream conveyor) are identical. The Progressive Logic discharge functions the same as a Slug Release. Initiating the Slug Release will also result in all products releasing, regardless of zone conditions. **In the progressive release mode for contact accumulation, it is extremely important to set every 5th logic module to basic.**

CAUTION

- CRUZcontrol Logic Assemblies are designed to be fail-safe.
- A loss of module power, a disconnected or severed cable, or a dirty or failed photoelectric sensor will all result in the stopping of a zone, initiating accumulation beginning from the affected zone assuming that air pressure is present.
- With Progressive Logic, failure of a Logic Assembly to function properly could possibly result in product accumulating with zones not stopping as required.
- While this should be unlikely due to the fail-safe nature of the Logic Assembly, the effects of such a failure should be considered. This type of failure could result in excessive line pressure, eventually causing product to push through the discharge zone of the conveyor. Jam detection sensors should be used as appropriate to minimize the effects of such a failure.
- A pressure switch should disconnect conveyor motors from running in a low or no air pressure situation.

13.4 NBC APPLICATION – CRUZ®LOGIC

13.4.1 Logic Modules and Release Rates

Your NBC conveyor comes with a field switchable logic module for every zone. All the logic modules are shipped in the basic mode. This will be indicated by a green light when the 24VDC power is activated.

13.4.2 Basic Release

In the basic release mode, all logic modules are set to basic. The release efficiency will generally be 40% to 50% depending on the conveyor speed and the type of release at the discharge of the unit. A timed pulse release is generally more efficient than a one time “flush” type of release.

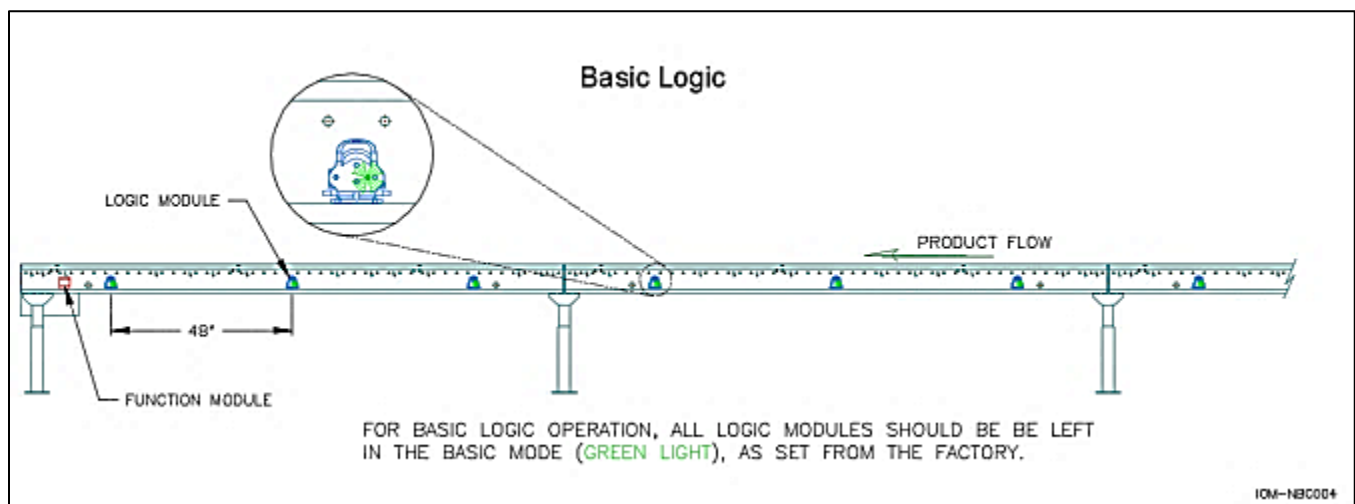

Diagram of Basic Logic, modes are all set to basic.

13.4.3 Progressive Release

Conveyors should not be operated with 100% of the logic modules switched to the progressive mode in the contact accumulation mode. This could cause line pressure issues if there is a jam since in the release mode, progressive ignores the photo sensors and dumps all the zones at once, in the same way slug discharge operates. **In the progressive release mode for contact accumulation, it is extremely important to set every 5th logic module to basic.** This limits a product jam, condition line pressure to 16' of conveyor. Failure to set every fifth logic module to basic can result in extreme line pressures that can damage your conveyor, product and could cause injury and void factory warranty.

Release efficiencies in progressive mode (every fifth logic module set to basic) are in the 70% to 90% range depending on speed and type of release at the discharge of the unit.

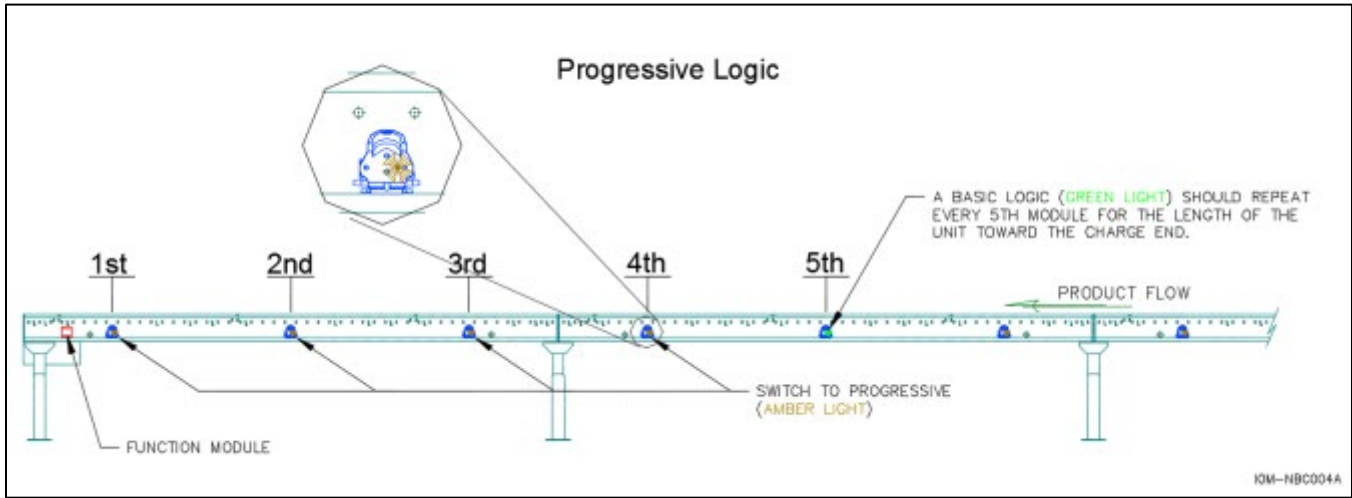

Diagram of Progressive Logic, modes are all set to progressive.

CAUTION

- Failures to follow the 4:1 logic module rule will result in voiding the factory warranty.

13.4.4 NBC Releasing Accessories

Two items are always required at the discharge end of an NBC accumulation conveyor:

1. A signal to release or accumulate product.
2. A method of stopping coasting product (contact accumulation only)



Release function module at discharge end of NBC conveyor. MHS Conveyor part number 1116732.

13.4.5 A signal to release or accumulate product

This is normally a 24V signal from the system PLC to the release function module of the NBC. These Function Modules will accept 115 VAC control inputs. There are some cautions that must be observed to avoid Function Module hardware failure. Part numbers and complete wiring descriptions for release function modules are explained in the NBC® Installation, Operation and Maintenance Manual – item number 1118140.

Exercise extreme caution in activating the slug release line instead of the logic line. If used at all, it should be limited to the discharge 20' or less of conveyor. A slug interrupt cable (item number 1117382) can be used to break this signal where you want the slug release to stop. It should be noted that the same result can be accomplished by switching the discharge logic modules from progressive to basic.

13.5 A METHOD OF STOPPING THE COASTING PRODUCT

The following diagrams describe three different methods of stopping coasting products.

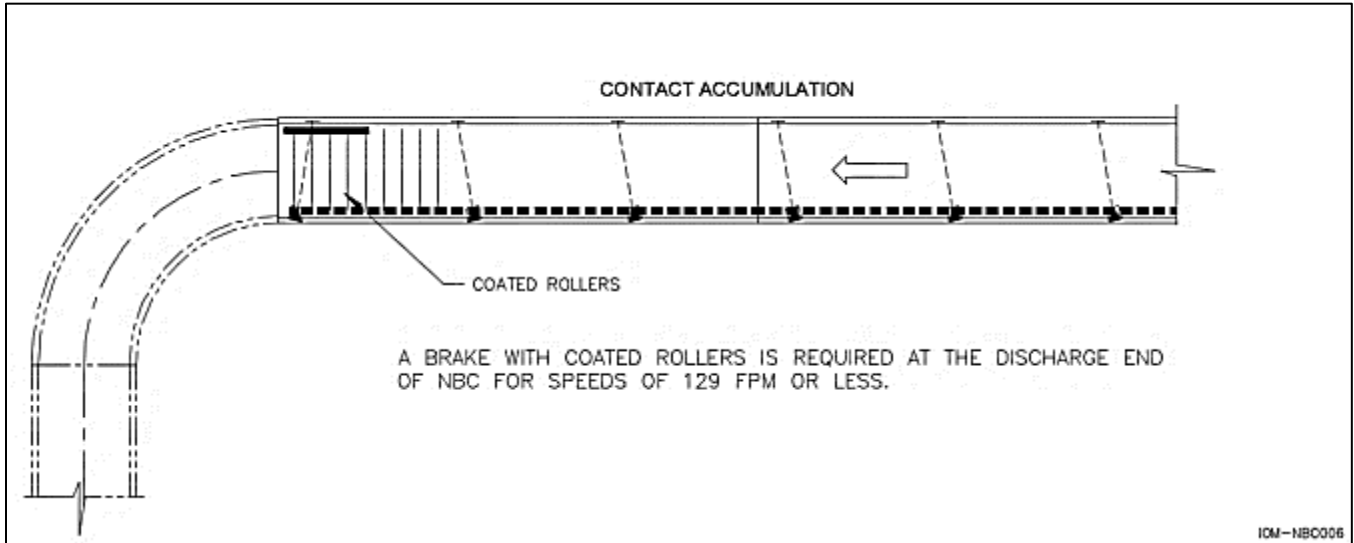

For speeds up to 129 FPM, a brake with six coated rollers is sufficient. Standard brake kits are available for NBC.

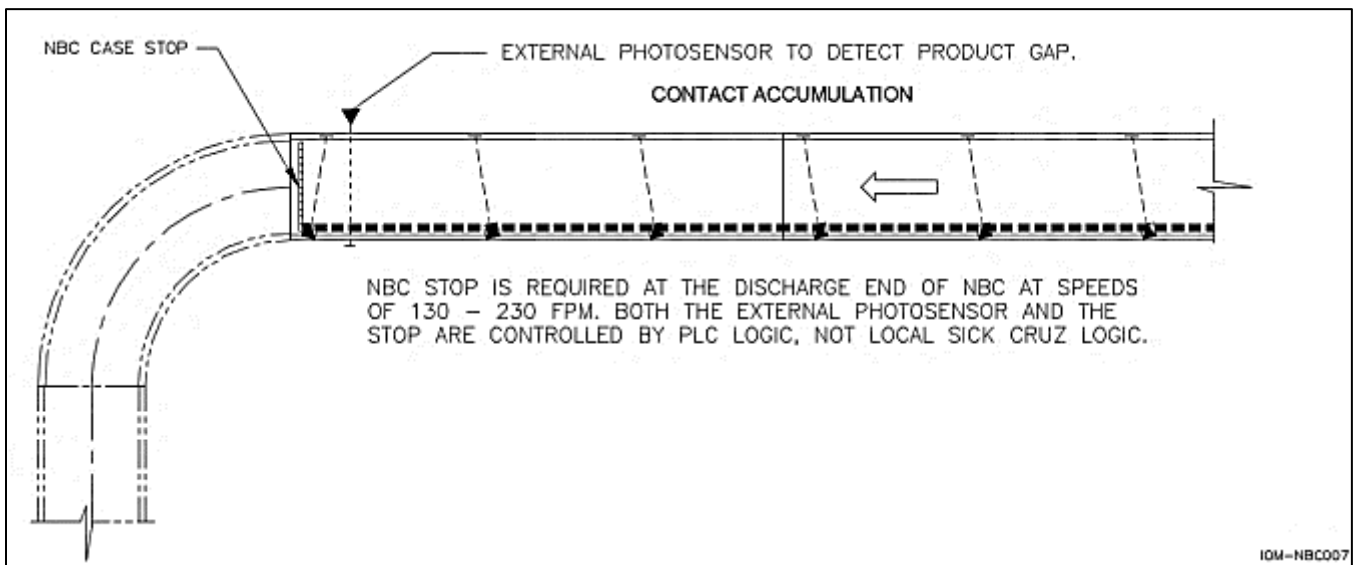

For speeds from 130 FPM to 230 FPM, a stop is recommended at the discharge end of NBC to stop the coasting product and begin accumulation. Standard stop assemblies are available for NBC. Please note that a stop cannot be allowed to come up under a product. An external PLC controlled sensor must be used to detect a gap and then activate a solenoid to raise the stop.

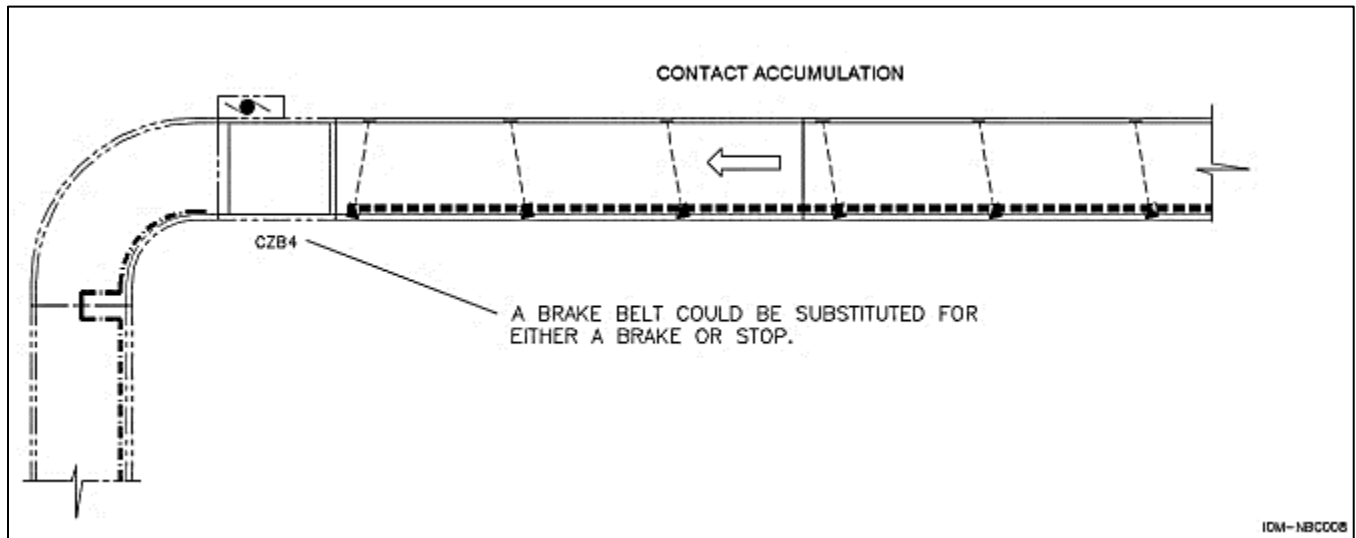

A belt unit downstream can be used in place of either a brake or a stop. If this belt option is selected, use the CRUZ®belt 4 series.

13.6 NBC COMPONENTS

CRUZcontrol Logic Assembly

The CRUZcontrol Logic Assembly consists of a polarized retro-reflective type photoelectric sensor, pneumatic valve and logic module integrated into one assembly.

The photoelectric sensor will function reliably on conveyor widths up to 34" between frames. The sensor is polarized and is not affected by shiny surfaces. On NBC applications, the reflector is mounted with a 6-inch offset from the photoelectric sensor, so that the sensor scans across the conveyor on a slight angle.

The sensor bracket, as provided, allows for easy adjustment of the sensor. An amber LED output indicator on the back of the sensor aids in the adjustment of the sensor. The LED is off if the sensor is not aligned, flashes if functional but marginally aligned, and is on steady if properly aligned. A green LED indicates power on status.

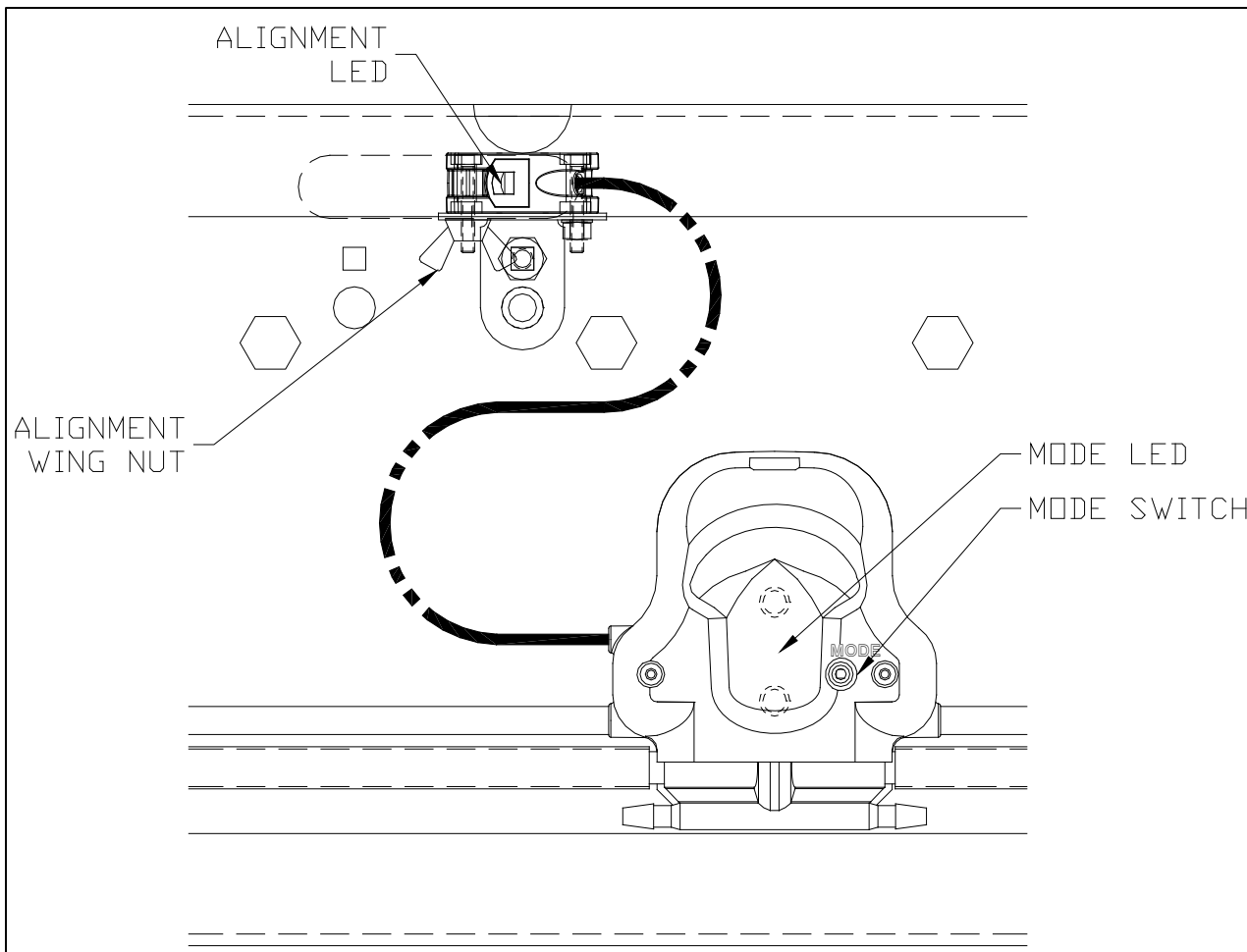

Logic Assembly Mode & Alignment

Logic Assembly Types

The CRUZcontrol Logic Assembly 1114947 provides an “air to brake” logic output utilizing a normally open pneumatic valve. The pneumatic valve is energized for a zone to be running.

Logic Assembly Functions

The CRUZcontrol Logic Assembly comes with a momentary button on the front of the housing allowing for selection of either Basic Logic or Progressive Logic mode. A Mode LED indicates either Basic (green) or Progressive (amber) has been selected. Pressing and then releasing the button toggles between the two modes.

Table 1: Logic Assemblies Functions

Function	Basic Logic	Progressive Logic
Single Accumulate	Yes	No
Slug Accumulate	No	Yes
Single Release	Yes	No
Slug Release	Yes	Yes

Logic Assembly Part Numbers

Table 2: Logic Assemblies Part Numbers

Part Number	Description	Used with
1114947	Basic/Progressive Logic Module, Air to Brake	NBC straight conveyor

13.7 FUNCTION MODULES

The Function Module provides electrical isolation for external controls and creates controllable zones to facilitate CRUZcontrol applications.

Function Module Types

There are two different Function Modules, each providing a set of functions: Full Function Module (1116731) and Release Function Module (1116732).

Table 3: Function Module Types

	Single Release	Slug Release	Pulsed Release	Zone Stop	Zone Delay	Logic Interrupt	Slug Interrupt	Zone Status
Full Function Module	x	x	x	x	x	x	x	x
Release Function Module	x	x		x		x	x	

Function Module Functions

All directions of upstream and downstream are given with respect to the Function Module. All jumper terminals are on pins 1-2 unless noted otherwise.

Table 4: Function Module Functions

Single Release	
Definition	Upstream logic line is turned on. The upstream Logic Assembly will release regardless of zone status.
Configuration	When using TB1; JP3, 1-2 to release the upstream Logic Assembly. When using TB4; JP4,1-2 to release the upstream Logic Assembly
User Action	Apply a high (24VDC/115VAC) signal to TB1, 1-2 if using isolated inputs. Or Apply a high (24VDC) signal to TB4, 3 if using a non-isolated input.

Slug Release	
Definition	The slug line is turned on. All Logic Assemblies that are connected in one continuous string will release at the same time regardless of zone status.
Configuration	When using TB2; JP1, 1-2 and JP2, 1-2 to release all Logic Assemblies.
User Action	Apply a high (24VDC/115VAC) signal to TB2, 1-2 if using isolated inputs.
Pulse Release	
Definition	Upstream Logic Assembly releases for a length of time set by the ZS ON potentiometer (0-20s) and then accumulates for length of time set by the ZS OFF potentiometer (0-20s).
Configuration	When using TB1; JP3, NC to oscillate the release of the upstream Logic Assembly. Adjust ZS ON and ZS OFF potentiometers from 0 to 20 seconds.
User Action	Apply a high (24VDC/115VAC) signal to TB1, 1-2 if using isolated inputs.

Logic Interrupt	
Definition	Upstream logic line is turned off. The upstream Logic Assembly is forced to accumulate when it detects a package regardless of the downstream zone status.
Configuration	When using TB1; JP3, 2-3 to accumulate the upstream Logic Assembly. When using TB4; JP4, 2-3 to accumulate the upstream Logic Assembly.
User Action	Apply a high (24VDC/115VAC) signal to TB1, 1-2 if using isolated inputs. Or Apply a high (24VDC) signal to TB4, 3 if using a non-isolated input.

Zone Delay	
Definition	Delays turning on the upstream logic line. After the downstream zone clears, the upstream Logic Assembly releases, but only after a length of time set by LOGIC potentiometer (0-20s).
Configuration	Adjust LOGIC potentiometer from 0 to 20 seconds.
User Action	No action required.

Slug Interrupt Downstream	
Definition	Downstream slug line is disconnected. Logic Assemblies downstream will not slug release when the Slug Release signal goes high.
Configuration	JP1, 2-3 all other jumper terminals should be on pins 1-2.

Zone Delay	
User Action	No action required.

Slug Interrupt Upstream	
Definition	Upstream slug line is disconnected. Logic Assemblies upstream will not slug release when the Slug Release signal goes high.
Configuration	JP2, 2-3 all other jumper terminals should be on pins 1-2.
User Action	No action required.

Zone Status Indication *	
Definition	Indicates full or empty status of the downstream zone on TB3.
Configuration	JP4, 1-2 and JP5, 1-2 for logic status or 2-3 for sensor status, all other jumper terminals should be on pins 1-2.
User Action	<p>Connect to TB3 for zone status.</p> <p>The output transition of the Zone Status from OFF to ON or ON to OFF can be delayed by the Zone Status ON and Zone Status OFF Delay potentiometers. This is typically used to indicate a zone is full only after a product is detected for period of time.</p> <p>* On power up there will be a 24s delay on zone status. If the state changes during that period, the delay will be eliminated.</p>

13.8 TERMINAL BLOCK DESCRIPTIONS

Table 5: Terminal Block Descriptions

Terminal Descriptions	
TB1	Single release, Logic interrupt Pulse release.
	This terminal is an isolated input; it must be used when signal voltage is from a supply that is different than the supply powering CRUZcontrol logic assemblies. It can be used when signal voltage is from same power supply that is powering CRUZcontrol logic assemblies.
TB2	Slug release.
	This terminal is an isolated input; it must be used when signal voltage is from a supply that is different than the supply powering CRUZcontrol logic assemblies. It can be used when signal voltage is from same power supply that is powering CRUZcontrol logic assemblies.
TB3	Zone Status (TB3 only available on full function module)
	This terminal is an isolated output; it must be used when signal voltage is from a supply that is different than the supply powering CRUZcontrol logic assemblies. It can be used when signal voltage is from same power supply that is powering CRUZcontrol logic assemblies.
TB4	Inputs
	This terminal is a non-isolated input; it must be used when signal voltage is from same power supply that is powering CRUZcontrol logic assemblies.
TB5	Outputs
	This terminal is a non-isolated outputs; output signal voltage is from same power supply that is powering CRUZcontrol logic assemblies.

13.9 JUMPER DESCRIPTIONS

Table 6: Jumper Descriptions

Jumper Descriptions	
JP1	Downstream slug control
	Pins 1-2 = slug pass through Pins 2-3 = slug interrupt Pins 3-4 = slug interrupt Pins 4-5 = singulation to slug crossover Pins NC = slug interrupt
JP2	Upstream slug control
	Pins 1-2 = slug pass through Pins 2-3 = slug interrupt Pins NC = slug interrupt
JP3	Release control at TB1
	Pins 1-2 = single release Pins 2-3 = logic interrupt Pins NC = pulsed released
JP4	Release control at TB4
	Pins 1-2 = single release Pins 2-3 = logic interrupt Pins NC = zone status input (determined by JP5)
JP5	Zone Status control (JP5 only available on full function module)
	Pins 1-2 or NC = downstream logic status Pins 2-3 = downstream sensor status

13.10 USE OF 115 VAC CONTROLS

Important information regarding the use of 115 VAC controls:

These Function Modules will accept 115 VAC level control inputs. There are some cautions that must be observed to avoid Function Module hardware failure.

Function Module signal inputs are protected against 500 volt spikes. 115 VAC control signal wiring run in conduit along with higher voltage motor wiring could experience voltage spikes that exceed the 500 volt limit. This can be prevented by running control wiring in separate conduit from motor wiring. Additional protection for the Function Module inputs can be achieved by using an MOV (metal oxide varistor) placed across the input terminals within the Function Module. Suggestions of suitable MOV's would include Panasonic ERZV07D241 or Little fuse V250LA2.

Long conduit runs with motor wiring for multiple motors, and the use of variable frequency drives, all contribute to electrical noise, with a good potential for high voltage spikes. If there is any doubt, the control signals to the Function Modules should be run in conduits separate from motor wiring.

The Function Module signal inputs have high impedance. When connected to some output devices, such as some PLC triac outputs, the inputs could sense an “on” state even if the output connected to it is not on. This can be corrected by adding additional loading to the output. This can be done by adding a loading resistor, placed across the output terminals.

Do not put this resistor inside of the Function Module. The size and wattage rating of the resistor would depend on the output characteristics of the PLC card. A typical value would be 10,000 ohms (10K ohms) and 2 watts. The resistor must be able to dissipate 1.32 watts at 115 VAC, so it will get warm.

CAUTION

- Do not put this resistor inside of the Function Module. The size and wattage rating of the resistor would depend on the output characteristics of the PLC card. A typical value would be 10,000 ohms (10K ohms) and 2 watts. The resistor must be able to dissipate 1.32 watts at 115 VAC, so it will get warm.

13.11 FUNCTION MODULE PART NUMBERS

Table 7: Function Module Part Numbers

Part Number	Description
1116731	Full Function Module
1116732	Release Function Module

Figure 1: Function Modules

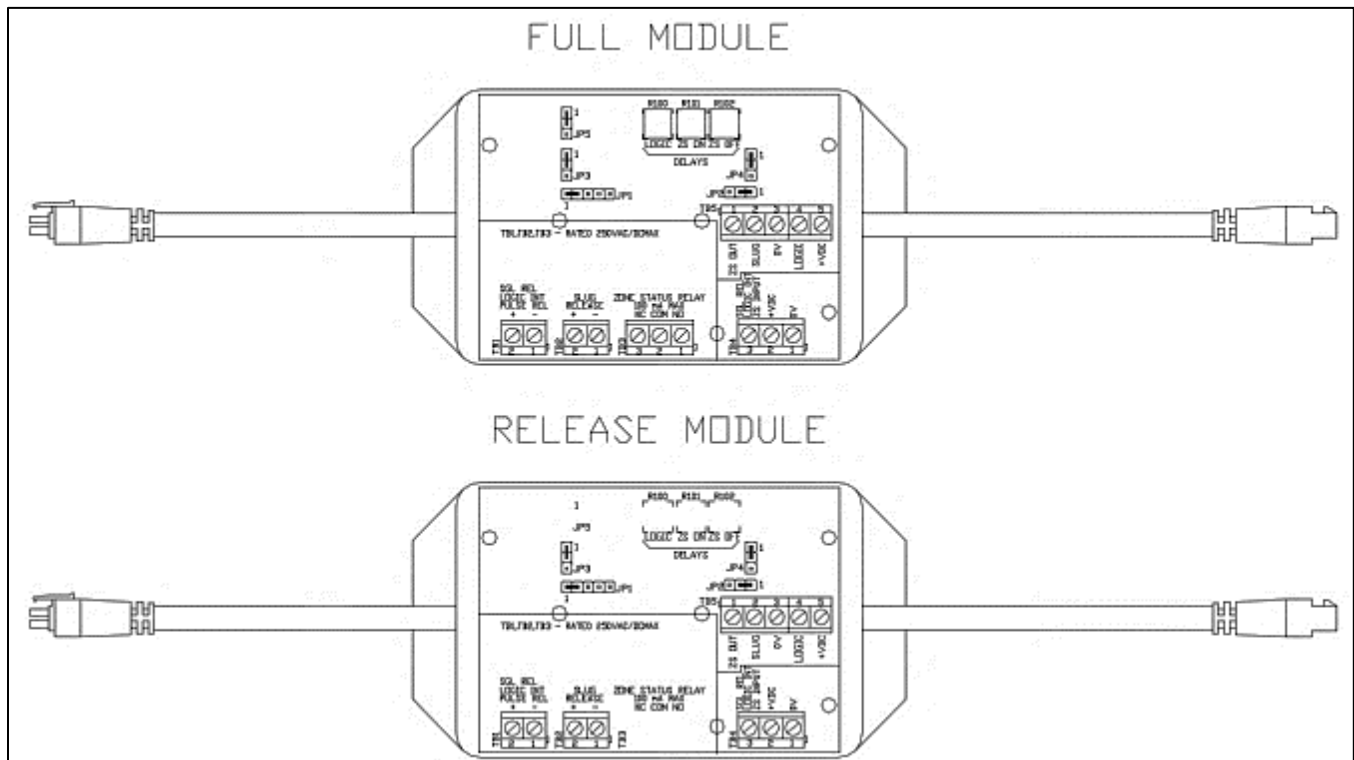

Figure 2: Full Function Module Board Layout

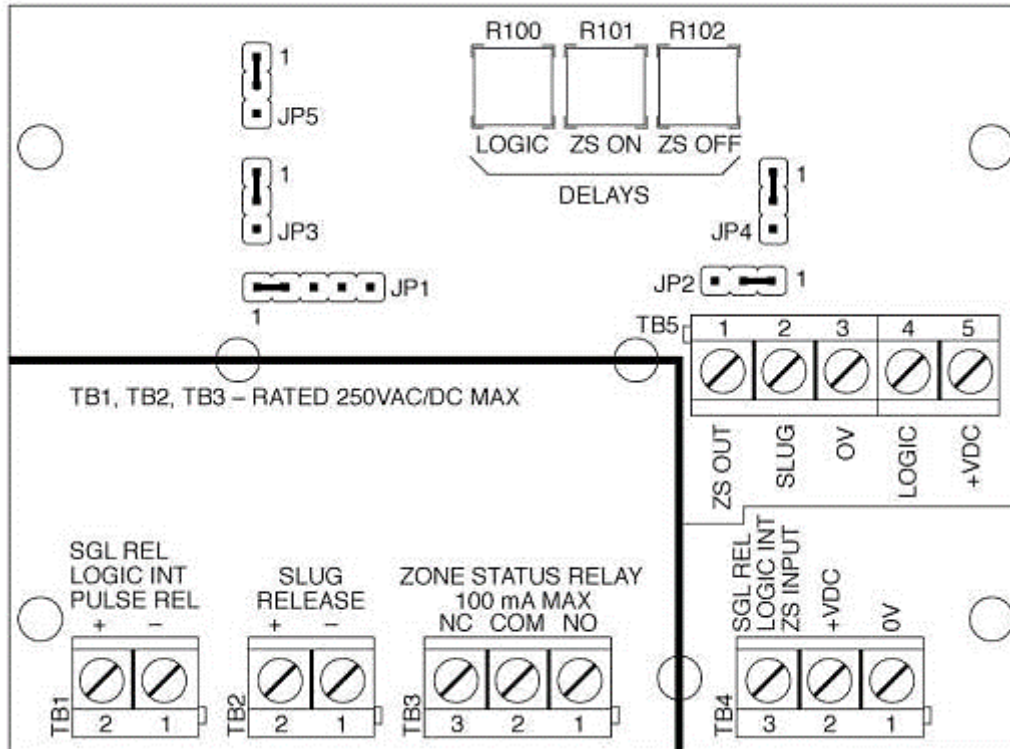

Figure 3: Full Function Module Circuit

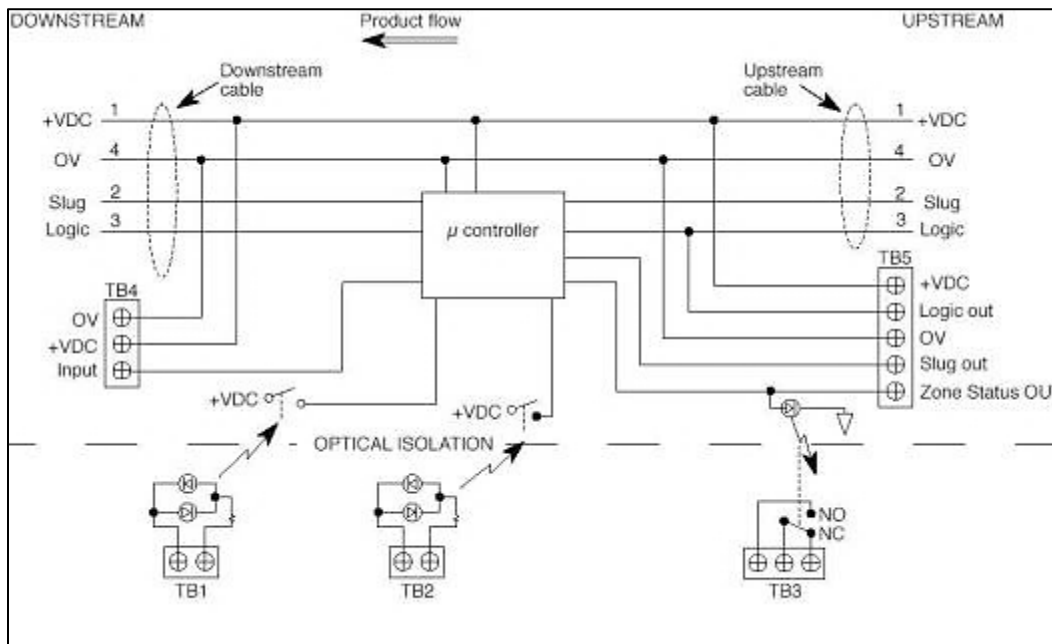

Figure 4: Release Function Board Layout

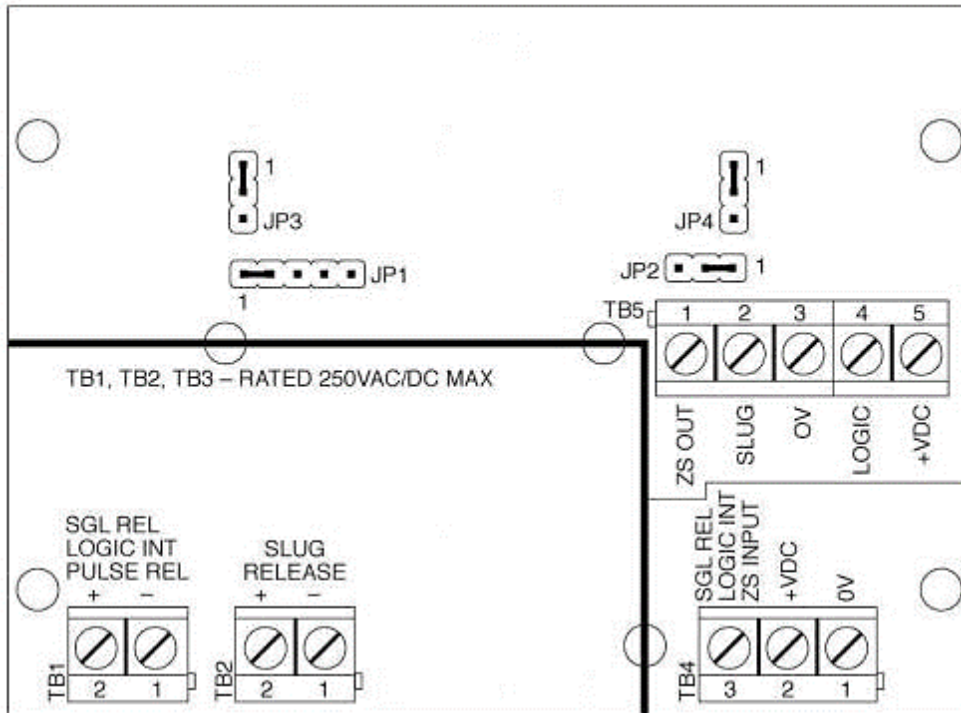
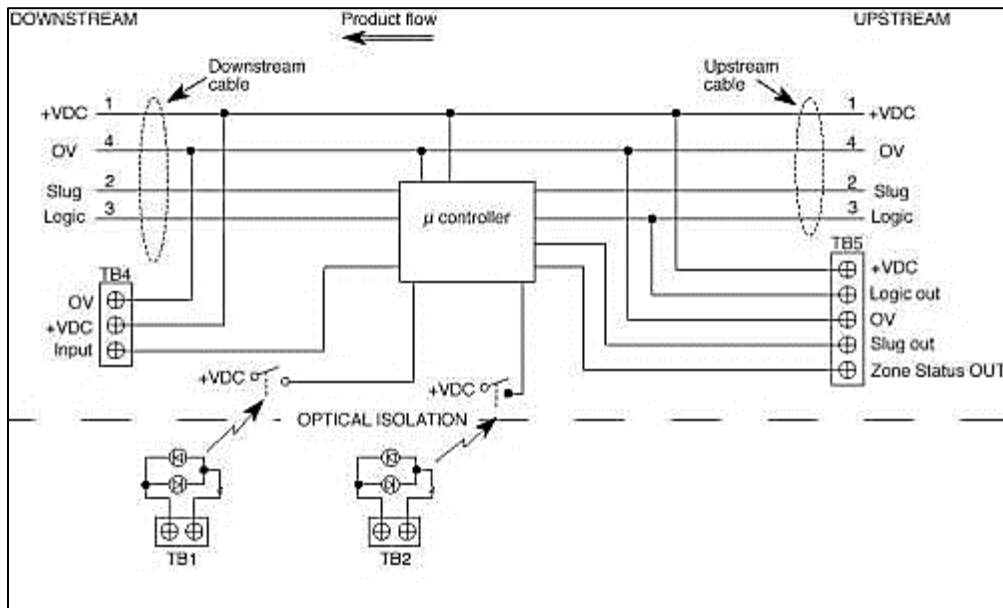

Figure 5: Release Function Module Circuit



14 NBC POWER SUPPLY REQUIREMENTS

A 24 VDC power supply is needed to power the logic assemblies and the function modules. One power “T” cable is prewired to each power supply. Power supplies are available in 120 VAC or 480 VAC input versions.

14.1 POWER SUPPLY REQUIREMENTS

CRUZcontrol operates from a Class 2 power supply voltage of 24 VDC. This limits the total number of CRUZcontrol Logic Assemblies that can be connected to one power supply. There is also a limit on the maximum number of Logic Assemblies that can be in one continuous string, based on the cable length and power requirement of Logic Assemblies. More than one string of Logic Assemblies can be connected to a power supply, as long as the power supply output rating isn’t exceeded.

The Function Modules require 10mA of current at 24 VDC. This needs to be considered, as it will reduce the total number of Logic Modules that can be connected to one Class 2 power supply to a quantity less than stated in Table 8.

Number of Zones	Number of Zones
End Tap (95W, 24VDC)	27
End Tap (95W, 28VDC)	35
Center Tap (95W, 24VDC)	54
Center Tap (95W, 28VDC)	46

Table 8: Maximum Number of Logic Modules per String – 100/240 VAC

14.2 POWER SUPPLY WIRING

Connection made between two Logic Assemblies using a T Cable.

This drawing illustrates a power connection made between two intermediate accumulation zones making use of a “T” Cable. NOTE that all power and control signals, including the Slug and Logic Signals, pass through the “T” Cable uninterrupted.

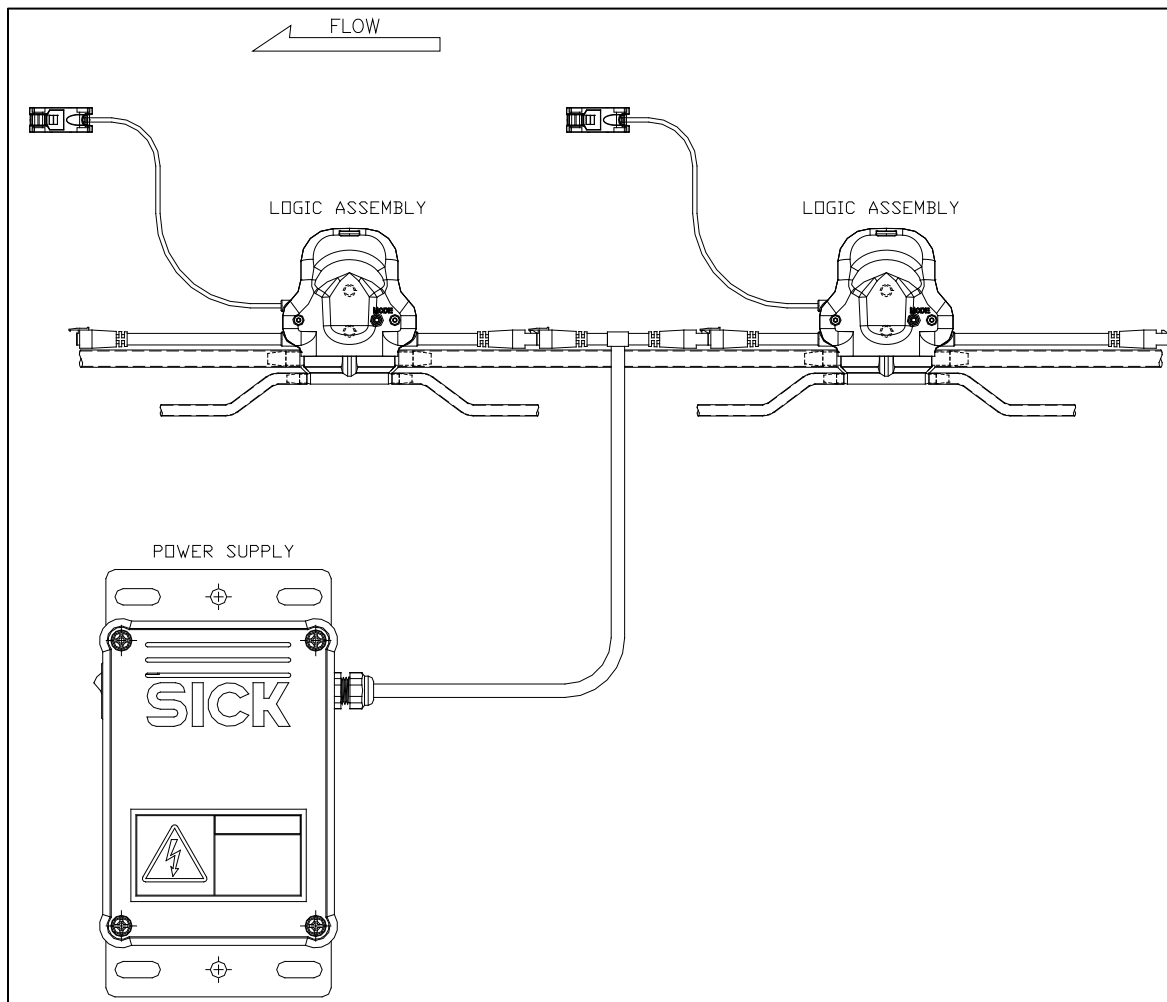

Figure 6: Two Logic Assemblies using a T Cable

A “T” cable must be installed between two logic module assemblies. Preferably located in the middle of the logic modules connected to the power supply.

One Power Supply used to power two separate CRUZcontrol sections.

This drawing illustrates the use of one power supply to power two separate, short CRUZcontrol sections on two different conveyors. A second "T" cable is required to connect the second CRUZcontrol section to the power supply. This can be done to make better use of the full capacity of a power supply.

It could be necessary to extend the T Cable leads to reach the power supply location. This should be done with a wire gauge large enough to prevent noticeable voltage drop. The number of CRUZcontrol zones that can be connected per string must also be reduced based on the voltage drop of the wire used.

The brown lead on the "T" Cable connects to +24 VDC on the power supply. The blue lead on the "T" Cable connects to 0 VDC on the power supply.

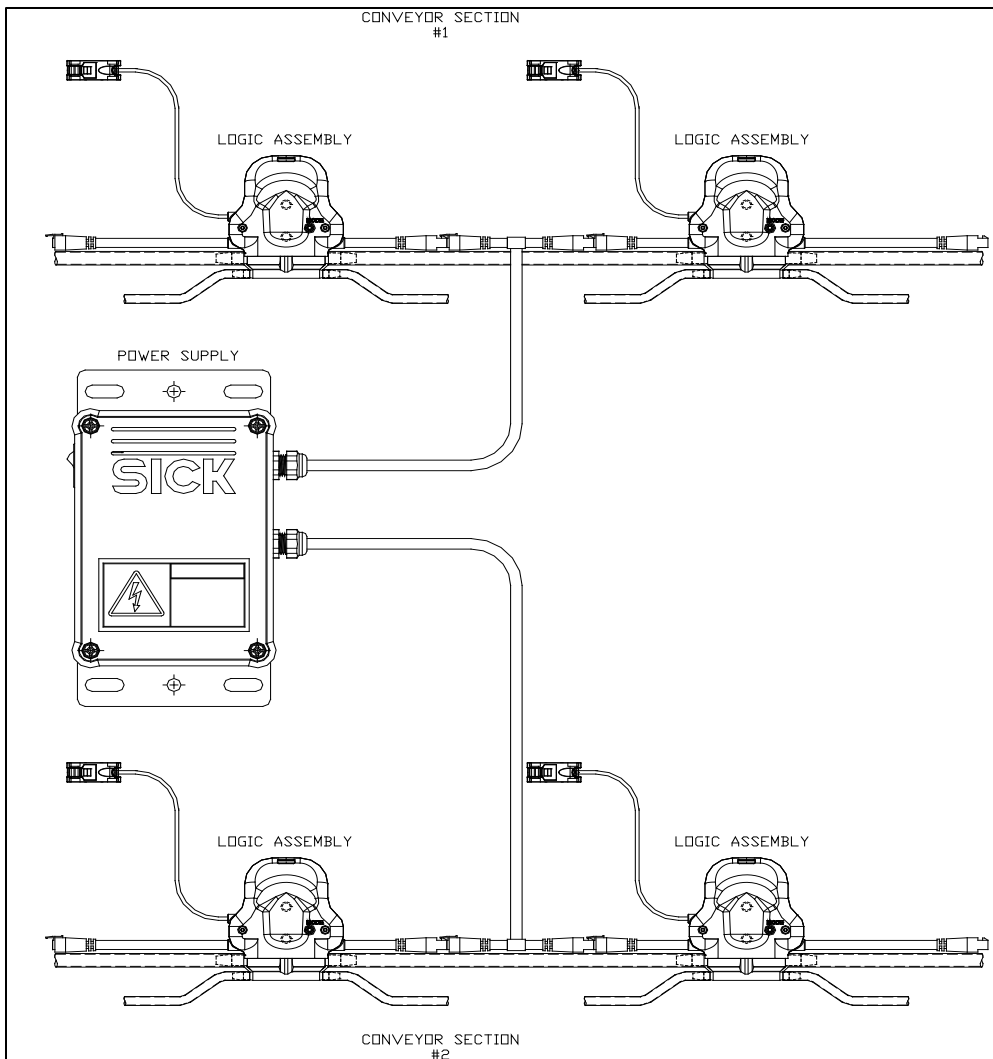

Figure 7: Two Separate CRUZcontrol Sections

Using two Power Supplies to power one extended CRUZcontrol section

A CRUZcontrol string with more than 54 Logic Assemblies would require the use of more than one power supply. This can be done, but it requires that the power supplies be isolated from each other at the +24 volt line. This drawing illustrates how to isolate the two strings making use of a Power Interrupt Cable. The + VDC line is not passed through, while the Slug Release and Singulation Release Signals as well as OVDC are connected to pass the signals through uninterrupted.

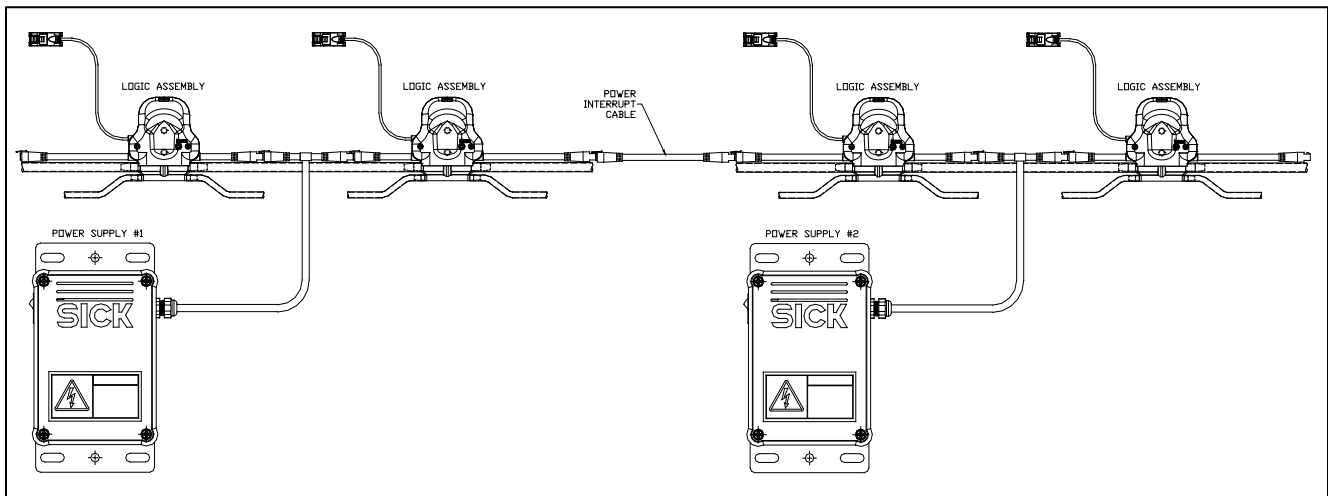

Figure 8: One CRUZcontrol Section with Two Power Supplies

Power Supply Part Numbers

Part Number		Description
Kit Part Number 1117431	1117972	PWS, 24VDC,3.9A,120VAC, NBC CLASS 2, W/ 2X2 T-CABLE
	1117937	BRKT, POWER SUPPLY,SICK NBC
Kit Part Number 1117432	1107030	PWS, 24VDC,3.8A,480VAC, NBC ,2 PH, CLASS 2, W/2X2 T-CABLE
	1117937	BRKT, POWER SUPPLY,SICK NBC
Cables	1117379	CABLE,CTRLS-T_CABLE-79"-2X2-FLYING LEADS
	1117380	CABLE,CTRLS-POWER INTRPT-2X2

Table 9: Power Supply Part Numbers

14.3 ACCESSORIES

Auxiliary Photoelectric Sensor

There is often a need to sense product presence on a CRUZcontrol equipped conveyor, with the sensors connected to a control system other than CRUZcontrol. To allow for this, adequate space has been provided alongside of the CRUZcontrol photoelectric sensors to allow for the mounting of a second independent photoelectric sensor, sharing the same holes through the conveyor side channels and the same reflector. Appropriate holes are provided for the photoelectric sensor mounting bracket. The discharge end of NBC conveyor is also provided with an additional mounting location for a photoelectric sensor and reflector.

The following kits are available, which include the photoelectric sensor and appropriate bracket. Even though not normally needed, an extra reflector and adhesive mounting tape is also included with each kit.

The 10-30 VDC photo sensors are similar to the CRUZcontrol sensors. They are light operate, with a 50 mA maximum output current, and come with a 27" cable (no connector).

Part Number	Description
1117727	PE, ASY SICK ZL PNP LIGHT OP 700MM LEAD W/ FLYING LEADS W/REFLECTOR & TAPE

Table 10: Photoelectric sensor

Reflector

Replacement reflectors can be ordered with the following part number.

Part Number	Description
400004	PE, REFLECTOR 4-3/8" X 1-1/8"
1153640	TAPE, FOAM DBL SIDED 3/4"SQUARE

Table 11: Reflector

Sensor Valve Assemblies

A Sensor Valve Assembly is used for applications not requiring accumulation logic, (controlling the zone with a PLC) but the solenoid valve and photoelectric sensor configuration as used in the CRUZcontrol channel is still desired.

Part Number	Description
1116736	LM, CRUZCONTROL SENSOR/VALVE W/ZL2 EYE,N.O. VALVE

Table 12: Sensor Valve Assembly

Extension Cables

The following extension cables are available to meet application requirements where longer zone lengths or skipped zones must be accommodated. Each cable has 4 conductors, with male and female 2X2 connector ends.

Part Number	Description
1117372	CABLE, CTRLS-EXT-39"-2X2 MALE-FEMALE
1117373	CABLE, CTRLS-EXT-78"-2X2 MALE-FEMALE
1117374	CABLE, CTRLS-EXT-157"-2X2 MALE-FEMALE

Table 13: Extension Cables

Discharge Logic Control

Discharge Logic Control refers to using a standard Logic Assembly set to Basic Logic mode to control the release from the last discharge zone of a length of CRUZcontrol. This is typically done when CRUZcontrol conveyor (of any kind) feeds non-CRUZcontrol conveyor. There are no air connections made to the valve section of the Logic Assembly. When used this way, the added Logic Assembly is known as the Discharge Logic Assembly (DLA).

The Discharge Logic Assembly is mounted on the charge end of the conveyor immediately downstream of the last (discharge) zone of a length of CRUZcontrol accumulation conveyor. It is connected to the Logic Assembly of the discharge zone as shown. There is no need for a Function Module to be attached to it. The DLA does not need to be given a release signal. Product blocking that photoelectric sensor will stop release from the CRUZcontrol discharge zone, until the photoelectric sensor clears again. This operation can usually be left enabled and ready to function regardless of whether the receiving conveyor is running or off. There would be no need to interface the CRUZcontrol operation with the receiving conveyor operation, since the functioning of it is based solely on product movement.

Figure 9: Discharge Logic Control

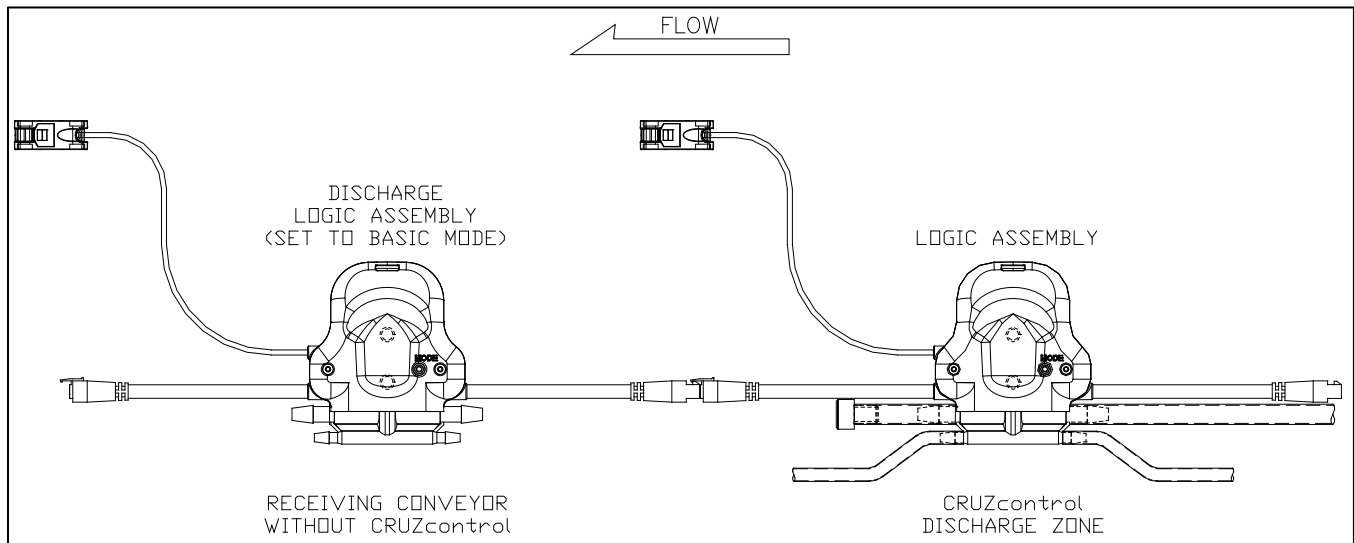

The following hardware listing is for two Discharge Logic Assembly kits consisting of the Discharge Logic Assembly, a reflector, and mounting brackets. The mounting brackets provide for the mounting of the Discharge Logic Assembly and reflector either ½" or 3" above a standard CRUZ side channel. Since every application is different, there will usually be a need to drill mounting holes for the brackets.

Table 14: Discharge Logic Assembly

Part Number	Description
1117859	KIT, NBC DISCHARGE LOGIC 1/2" TOR (½ inch above rollers scan height)
1117860	KIT, NBC DISCHARGE LOGIC 3"TOR (3 inch above rollers scan height)

15 CRUZCONTROL ON SITE INSTALLATION

Pre-installed on the conveyor

- The CRUZcontrol Logic Assemblies are installed on the side channel of the conveyor bed.
- The air supply tubing (3/8" OD X 1/4" ID) for the conveyor is plumbed along the length of the conveyor bed, passing through each Logic Assembly.
- The zone control air is plumbed (1/4" OD X .160" ID) from the Logic Assembly to the zone air pucks or cylinders.
- The photoelectric sensors are mounted for each zone, along with the reflector across the conveyor bed. The photoelectric sensors are tested to insure proper alignment with the reflectors, as well as proper functioning of the Logic Assemblies.

Field Installation

Bed to bed connections:

- Connection of air supply tubing between conveyor beds, terminating the ends of the air supply tubing
- Connection of the Logic Assembly upstream or downstream cable from the last zone of a conveyor bed to the first zone in the next upstream conveyor bed

System connections

- Connecting the air supply to the conveyor
- Connecting a power supply into the string of Logic Assemblies
- Adding extension, power interrupt, or adapter cables if needed
- Adding auxiliary photoelectric sensors as required for lead zone and "line full" conditions.
- Providing a release signal to the function module at the discharge zone

Figure 10: Logic Assembly

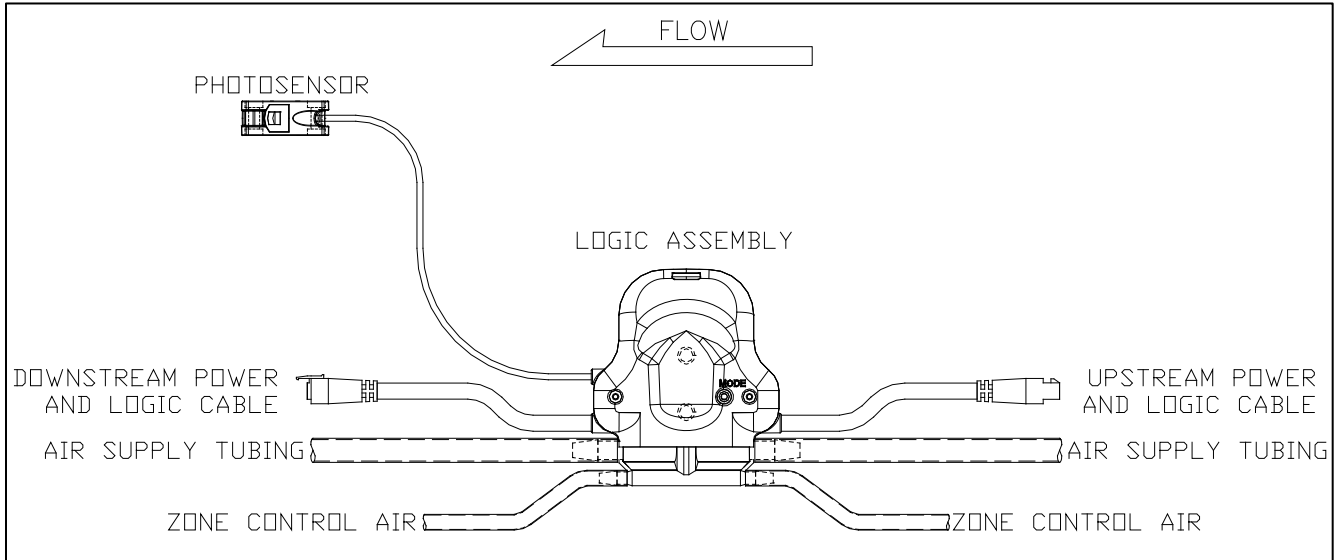

16 CONVEYOR FLOW

The logic assembly wiring is “in-line” for left hand flow conveyors; for right hand flow conveyors the wiring direction will be reversed. Cables will cross under the logic module assembly.

Figure 11: Left Hand Flow Conveyor Bed

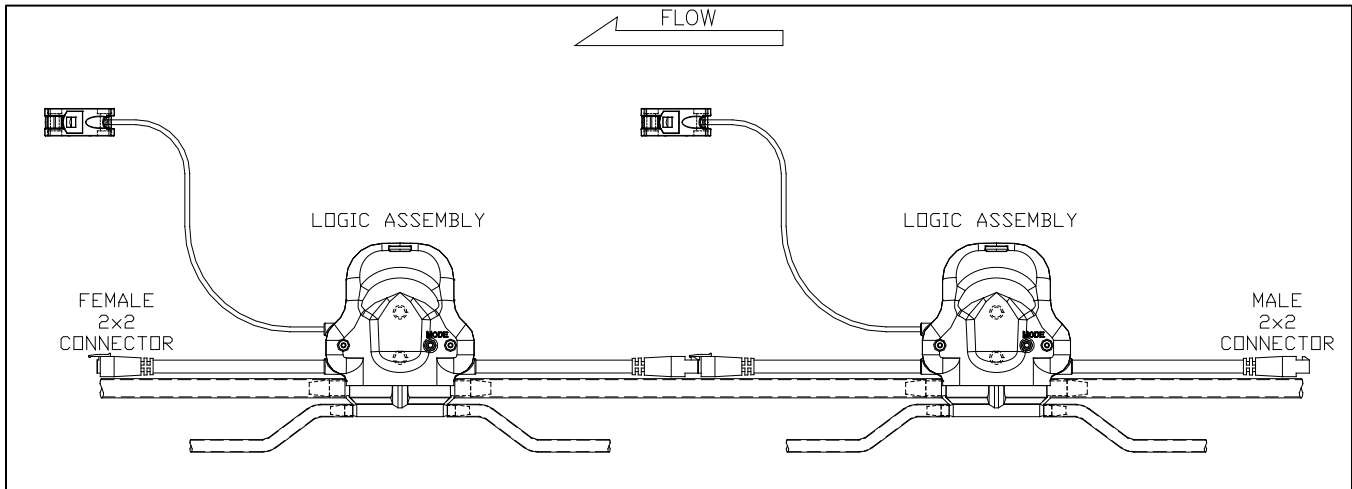
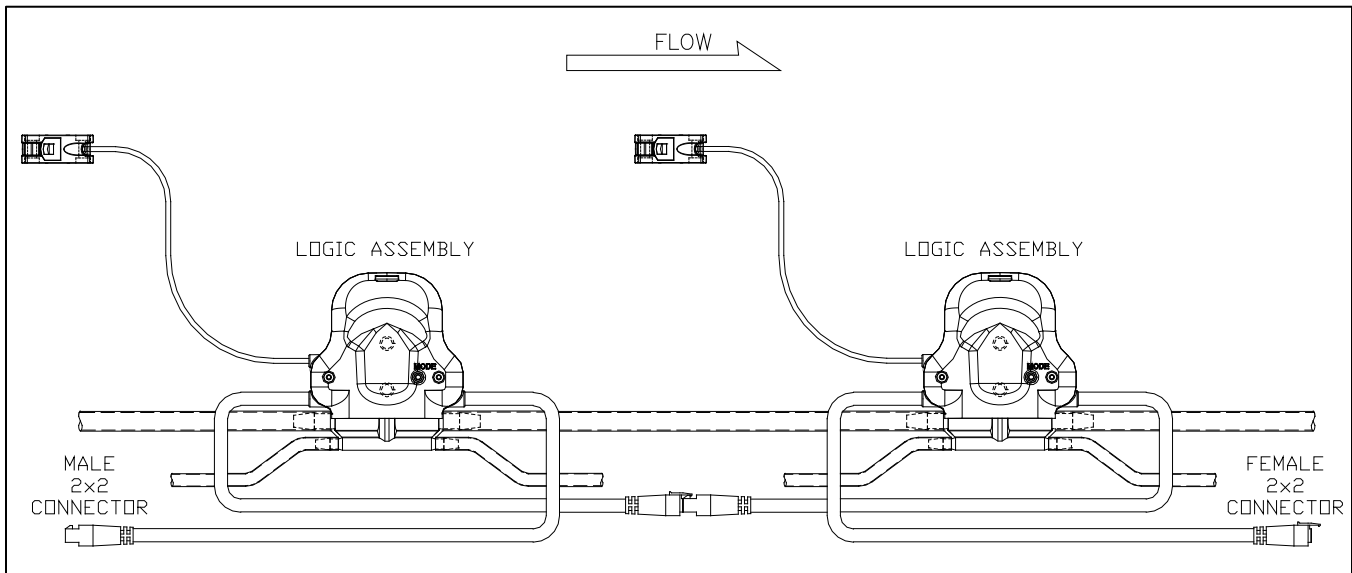

Figure 12: Right Hand Flow Conveyor Bed



Example 1: Releasing from CRUZcontrol

Releasing from CRUZcontrol	
Problem	Releasing Accumulated Product
Solution	When using CRUZcontrol the product will automatically accumulate. A signal must be given to the function module to get it to release.
Configuration	Plug Function module into discharge zone. All jumpers are set to pins 1-2. Give function module a release signal either through the isolated input as shown in Figure 15 or through the non-isolated inputs as shown in Figure 16.
Operation	Product will release for as long as the release signal is given.

Figure 13: Isolated Input Single Release

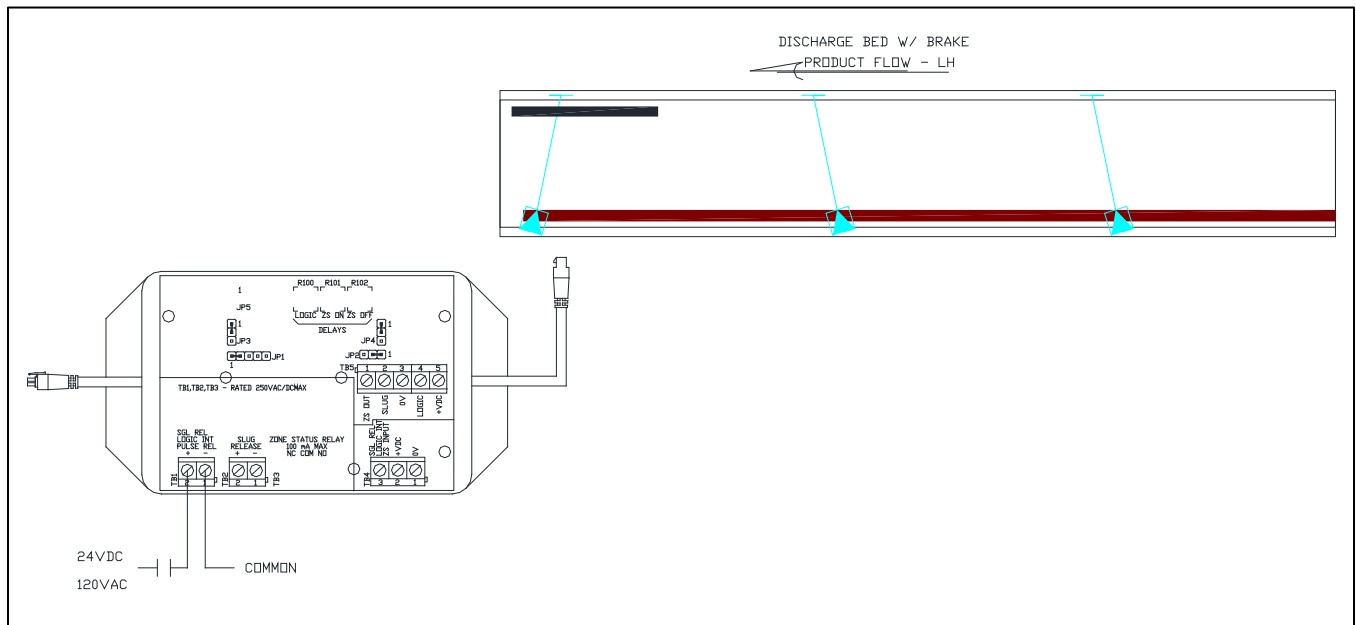
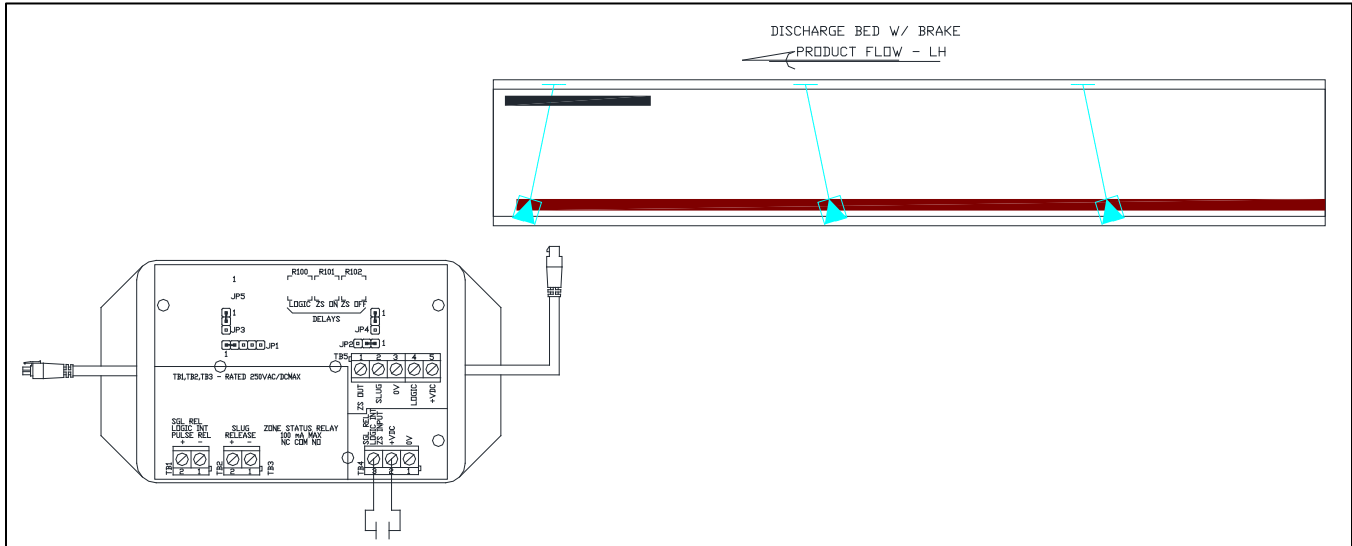

Figure 14: Non-Isolated Input Single Release



Example 2: Creating a work zone.

Creating a work zone	
Problem	Creating a work zone in the middle of a section of CRUZcontrol
Solution	Use the release function module and interrupt the downstream logic to start accumulation.
Configuration	When using TB1 to interrupt the logic set jumper terminal JP3, 2-3 When using TB4 to interrupt the logic set jumper terminal JP4, 2-3
User Action:	Apply a high signal to TB1 (24Vdc/120Vac) or TB4 (24Vdc)
Operation	All product stops at a specific accumulation zone, when the contact is closed and is released when the contact is opened.

Figure 15: Work Zone

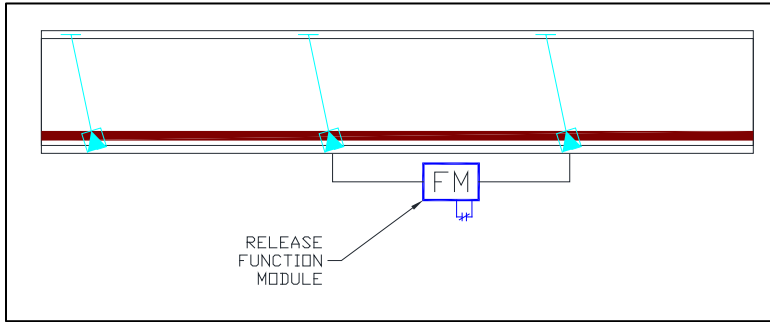

Figure 16: Work Zone Using TB

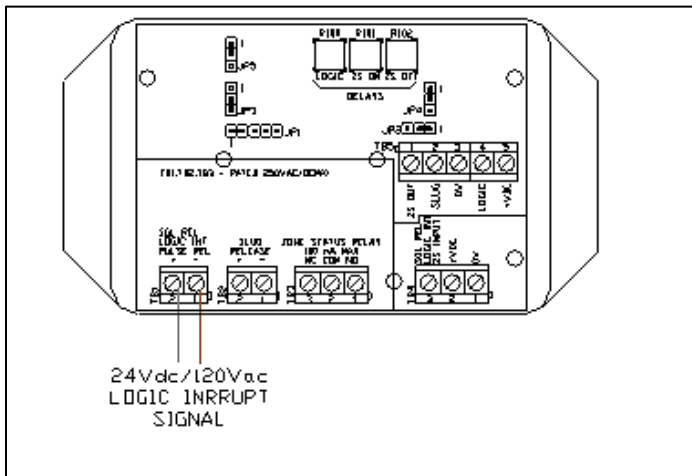
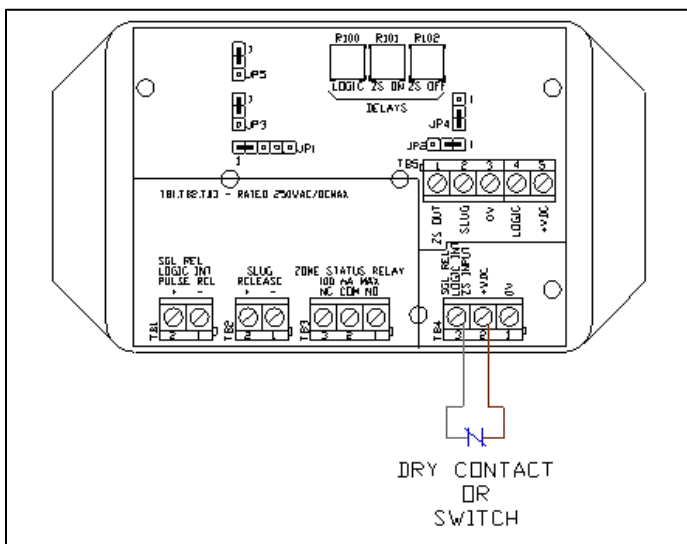

Figure 17: Work Zone Using TB1 4



Example 3: NBC accumulation release to conveyor

NBC-C accumulation release to feed induction conveyor	
Problem	Creating line pressure when feeding a slower conveyor
Solution	Use logic assembly as a discharge logic assembly
Configuration	Place Discharge Logic Assembly (DLA) downstream of conveyor discharge zone. Set mode to basic. Do not plumb airline to logic assembly.
User Action:	None needed.
Operation	The Discharge Logic Assembly is connected to the Logic Assembly at the discharge end of the NBC conveyor. There is no need for a Function Module to be attached to it. The DLA does not need to be given a release signal. Product blocking that photoelectric sensor will stop release from the NBC discharge zone, until the photoelectric sensor clears again. This operation is left enabled and ready to function regardless of whether the induction conveyor is running or off. There is no need to interface the CRUZcontrol operation with the induction conveyor operation, since the functioning of it is based solely on product movement.

NBC conveyor, when accumulating and subsequently releasing accumulated product, will result in some amount of line pressure at the discharge end of the conveyor. This is caused by the momentum of moving product coasting to a stop as it accumulates.

Example

The NBC is running at 180 FPM, feeding the induction conveyor section prior to a pick zone module diverter. Without proper control of the discharge from the NBC, cartons released to the induction conveyor could possibly overdrive it and push past the 90 FPM section onto the 180 FPM section, not permitting product gapping to occur as required for the diverter to function properly.

The mounting location of the Discharge Logic Assembly photoelectric sensor and the reflector will determine release performance. A good starting point would be to locate the photoelectric sensor 12" downstream from the charge end of the induction conveyor, and the reflector 18" downstream from the charge end. The final locations should be determined based on system performance.

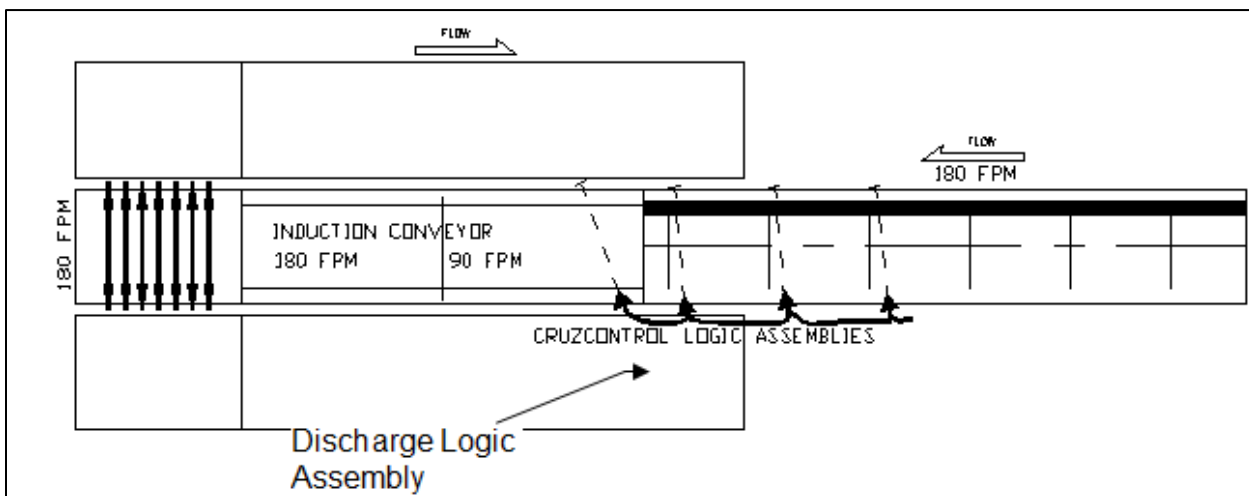

Example 4: Product Gapping

The following describes a technique, using CRUZcontrol, which creates a gap in a train of moving product. In the situation described, the gap is used to allow for the raising of a product stop. This would apply primarily to the progressive mode of accumulation control, which accumulates and discharges from accumulation with only minimal gaps between products.

The following illustrates an NBC accumulation lane used to release product to a merge conveyor. A Product Stop is located at the end of the accumulation lane, controlled by the solenoid valve as shown. The last two accumulation zones are also provided with brakes, as shown. These brakes are controlled by the CRUZcontrol Logic Assemblies that also control the zone drive. Also shown just prior to the Product Stop is a Product Present Photosensor.

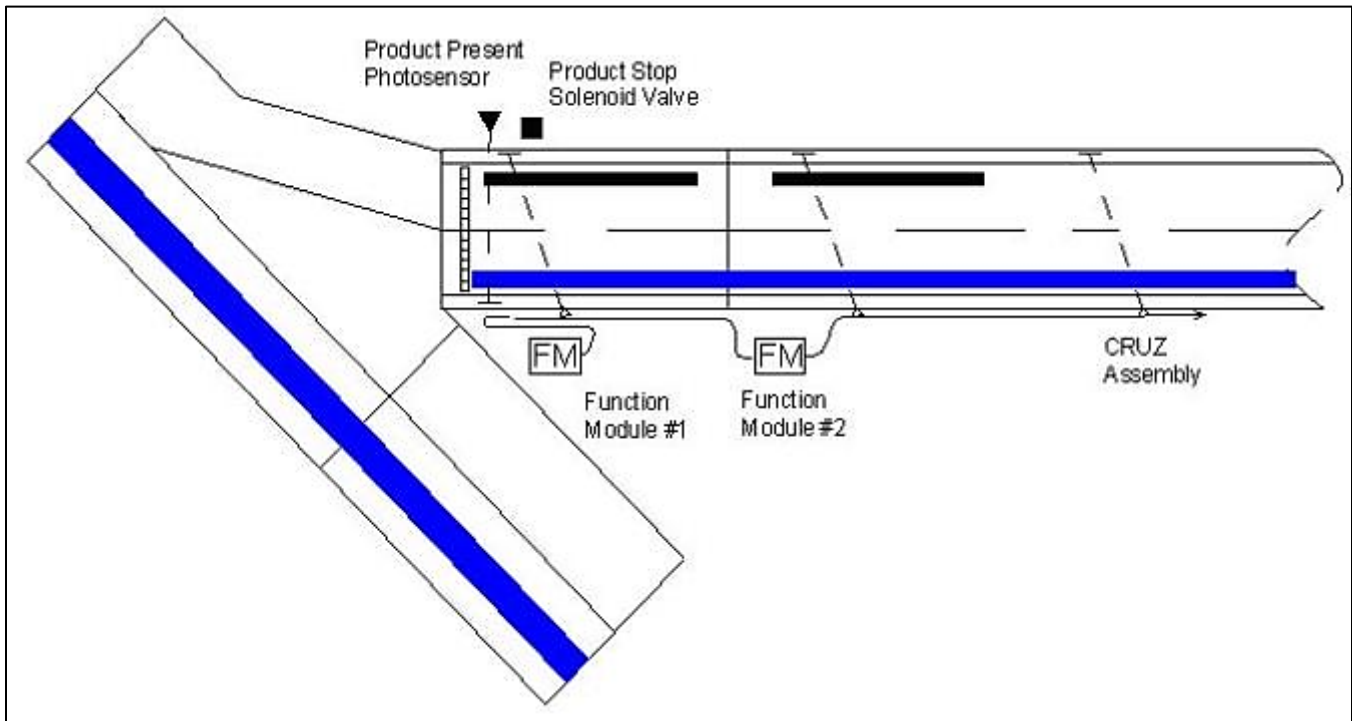

Operation

The Product Present Photosensor is connected to a PLC (programmable logic controller). The Photosensor is used to sense if product is accumulated behind the Product Stop, ready to be released. The Photosensor is also used to sense a gap in the flow of product adequate enough to raise the Product Stop after releasing product from the lane.

The Product Stop is solenoid activated, and controlled by the PLC. The stop is lowered by energizing the solenoid.

Function Module #1 (a Release Function Module) is configured and wired for Singulation Release operation. (Refer Table 4). The signal provided to the Product Stop solenoid is also connected to Function Module #1.

When the Product Stop is raised (solenoid and Function Module not energized), product blocking the Photosensor of the CRUZcontrol Logic Assembly will result in the conveyor zone going into accumulation and the zone brake being activated. This in turn enables accumulation beginning with the next upstream accumulation zone, once the Photosensor in that zone is blocked.

Function Module #2 (also a Release Function Module) is configured and wired for Logic Interrupt operation (Refer to Table 4). When it receives a signal (from the PLC), it passes the logic signal from the downstream accumulation zone to the upstream accumulation zone. Accumulation and release function normally, as if there no Function Module installed.

To create a gap in the flow of product, the PLC signal to Function Module #2 is turned off. This puts the zone upstream of Function Module #2 into accumulation mode, once its Photosensor is blocked. The brake in the zone is also set whenever the zone is set to accumulate.

16.1 OVERVIEW – MHS CONVEYOR CRUZCONTROL LOGIC MODULE

This section describes the development requirements for the MHS Conveyor CRUZcontrol logic module to be used with NBC. The new modules will be a complete solution that controls product flow through either “basic” and “progressive” accumulation with single or slug release. “Basic” accumulation may also be described as single accumulate where product detection in two consecutive zones will cause the upstream zone to accumulate. “Progressive” accumulation is also known as slug accumulate, which stops flow at the furthest downstream zone when product is detected.

A CRUZcontrol module will be mounted at each conveyor zone and connected in series with the neighboring upstream and downstream zones. The CRUZcontrol module will be comprised of a retro-reflective sensor, logic module with integrated pneumatic valve, and daisy chain connections. The retro-reflective sensor attached to the CRUZcontrol module will be located in the same zone (local zone) as the CRUZcontrol module and the valve will control the local zone.

16.1.1 Conveyor Details

Table 15: Conveyor Specification

Width (BF)	16 in. (400mm), 22 in. (550m), 28 in. (700mm), 34 in. (850mm)
Zone Length	48 in. (1219mm)
Roller Diameter	1.9 in. (48mm)
Roller Pitch	2.0 in. (76 mm), center to center, 3.0 in. (114 mm) center to center
Reflector Hole Size	13/16 in. x 1-9/16 in. slot
Sensor Skew	6.0 in. (150mm), maximum
Steel Thickness	12 Gauge
Pneumatic Type	Air to Brake
Working Air Pressure	40 PSI, maximum
# of Pucks per Zone	2
Minimum Product Height	0.5 in. (12.7mm)

Figure 18: MHS Conveyor CRUZ-Channel

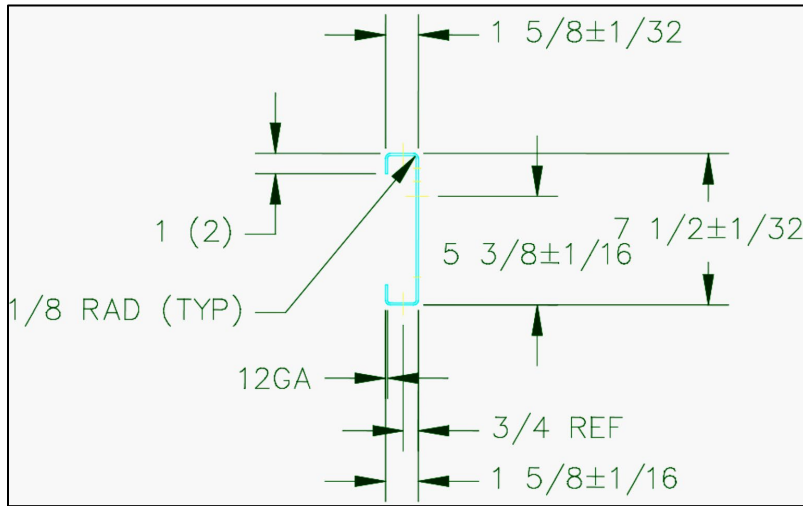
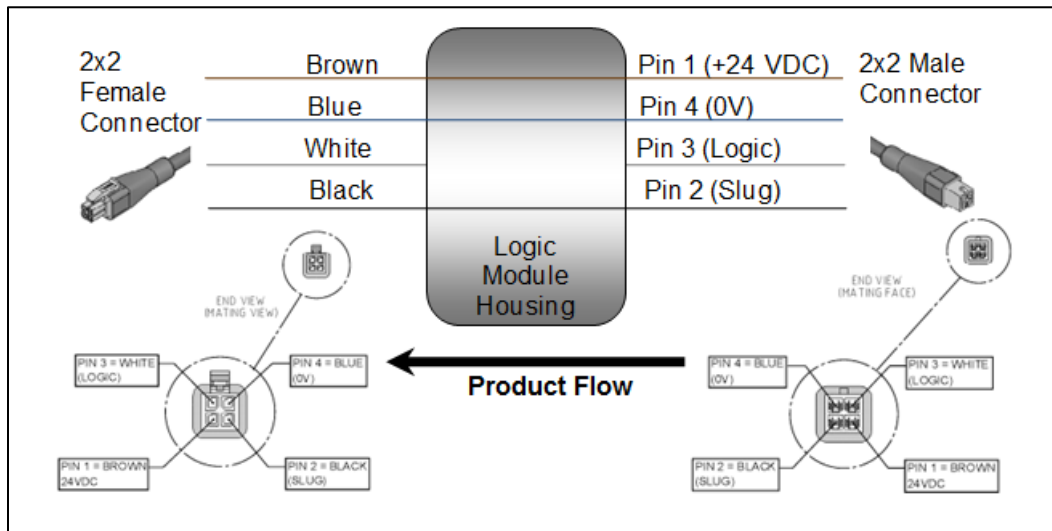

Figure 19: Logic Module Wiring for over molded 2x2 Daisy Chain Cables



16.1.2 Description of Logic

Two accumulate modes will be selectable on the module and two release modes will be available via wiring. Their operation is described below. NOTE that both single and slug release is available in basic mode while progressive mode will only slug release due to the logic (refer to Table 20).

Table 16: Logic Function

Function	Basic Logic	Progressive Logic
Single Accumulate	Yes	No
Slug Accumulate	No	Yes
Single Release	Yes	No
Slug Release	Yes	Yes

Basic Accumulation Module

In accumulation, any two consecutive sensors detecting product will cause the upstream zone of the two consecutive zones to deactivate until the downstream zone is no longer detecting product. The logic signal is passed upstream on Pin 2.

Figure 20: Basic Accumulation Logic

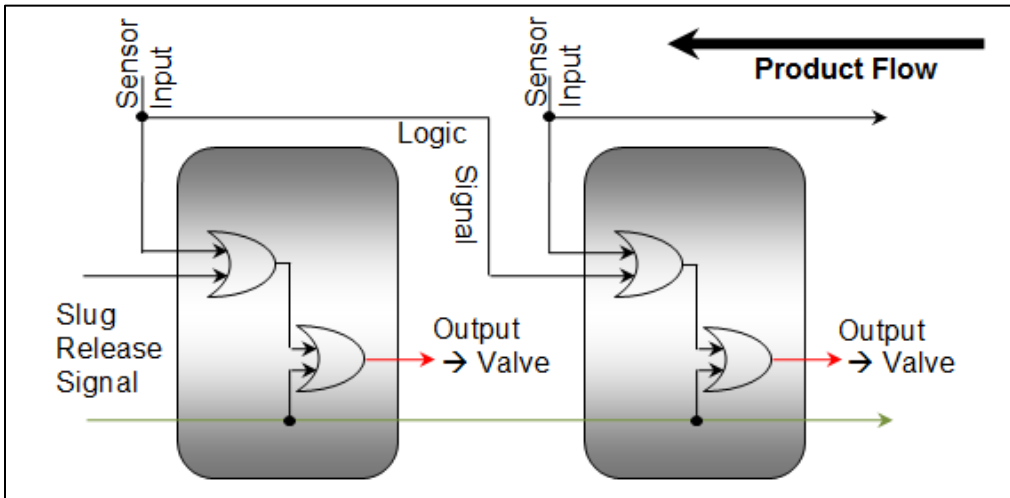

For single release, a given zone will release once the sensor in the downstream zone is clear of product. This may be done by removing product or applying an electrical release signal (+VDC) to PIN 2 and this also applies to the discharge zone.

When using slug release, all zones to which the slug line is connected will be activated simultaneously. This is initiated by applying supply voltage to PIN 4.

Progressive Accumulation Module

In accumulation, a zone will not deactivate until the furthest downstream sensor is detecting product and deactivates. The next upstream zone will then become the furthest downstream zone and deactivate when the sensor is blocked. The logic signal is passed upstream on PIN 2.

Figure 21: Progressive Accumulation Logic

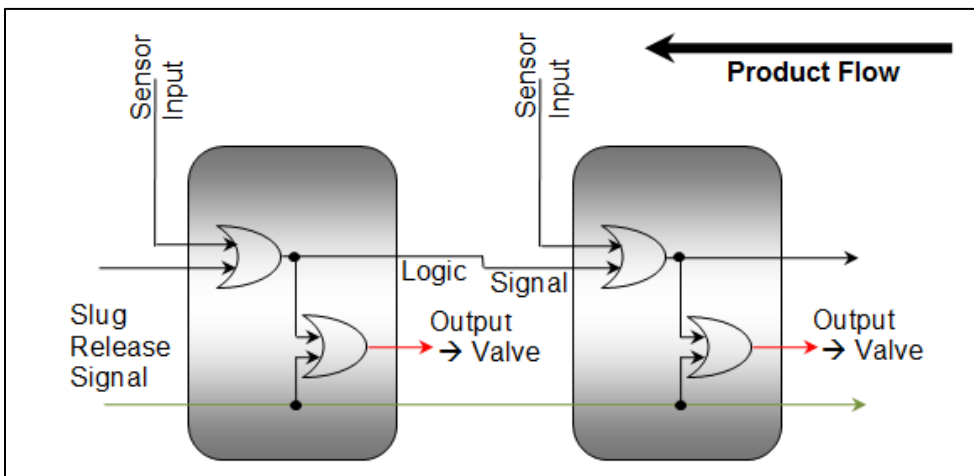

Progressive mode only allows slug release. All zones to which the slug line is connected will be activated simultaneously. This is initiated by applying supply voltage to PIN 4. The same effect may be achieved by applying an electric release signal (+VDC) to PIN 2.

Pneumatic Valve

The pneumatic valve shall be embedded in the logic module housing and satisfy the requirements outlined in Table 20.

Table 17: Pneumatic Valve Specification

Operating Pressure Range	0-40 PSI (0-2.75 bar)
Flowrate Capacity	≥ 0.04 Cv (40 NI/m)
Ventilation Capacity	≥ 0.04 Cv (40 NI/m)
Power Consumption	1W
Minimum Supply Voltage	19.2 VDC
Maximum Supply Voltage	27.6 VDC
Duty Cycle	100%
Life Expectancy	100 million cycles
Input Air Connection	3/8 in. (9.5mm) barbed fitting
Output Air Connection	1/4 in. (6mm) barbed fitting
Operating Mode	N.O. (Air to Brake)
Air supply	Non-lubricated, 5 micron or less

16.1.3 Sensor/Valve Assembly

The Sensor/Valve Assembly module differs from the standard module in that it does not have a female cable connection, does not connect to a neighboring module, does not contain logic, and has a unique wiring scheme on the male connection. This module may be simply described as a junction box with connection to provide +VDC to the sensor and valve, sensor output to the PLC, and valve input from the PLC. The male connection interface will be a cable with flying leads and have two meter (2m) length. The jacket shall be stripped, and conductors perforated. See the current Sensor/Valve Assembly, E0006229, for reference.

16.1.4 M12 Sensor Connection used with WTR style sensors

The M12 Sensor Connection module differs from the standard module in that it does not have the sensor hard wired to the module. Instead, a cable with female M12 connector will be provided for connection with standard sensors (i.e., WTR style sensors). This connection will have a 28 in. (711mm) length and right angle connector. The module requires a PNP sensor input signal that is either Light Operate from a retro-reflective sensor or Dark Operate from a proximity sensor. Pin-out may be found in Figure 30.

Figure 22: M12 Sensor Connection Pin-out

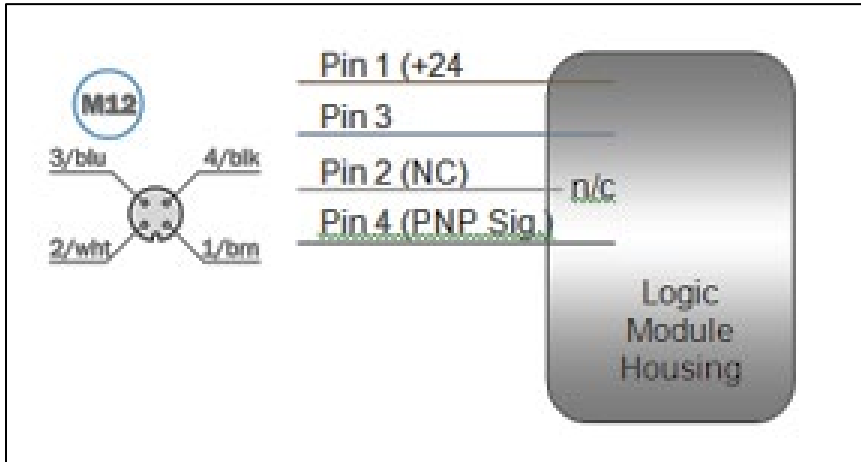

Adaptor Cable for M12 Connector

To connect the M12 logic module or M12 WTR sensor, a conversion cable is required. The adaptor cable allows the M12 connector to plug into the 2x2 connector. See Table 21 for types.

16.2 POWER SUPPLY

A variant of the CRUZcontrol power supply shall be developed with 2x2 connectivity and be UL Listed as Class II. Two input power options will be available:

- 115/230 VAC, single-phase
- 480 VAC, two (2)-phase supply

Cables

Application specific cables will be necessary in certain cases. A list of necessary components may be found below, NOTE that male refers to a male housing on 2x2 connections while female refers to a female housing; See Part Number Listing Table 19 Accessories w/2/2 Connections.

Figure 23: "T"- Cable Wiring

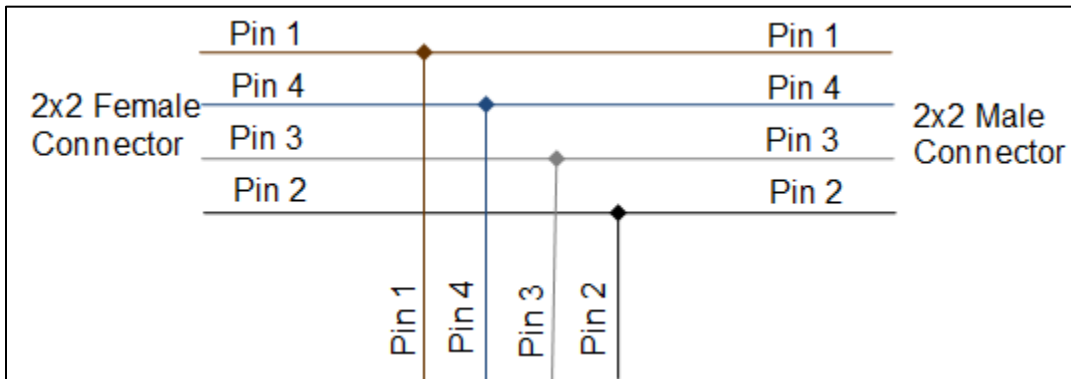

Figure 24: Power Interrupt Wiring

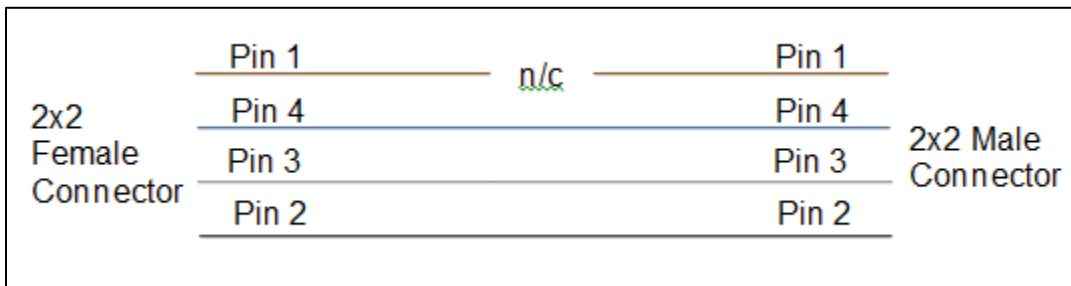

Figure 25: Logic Interrupt Wiring

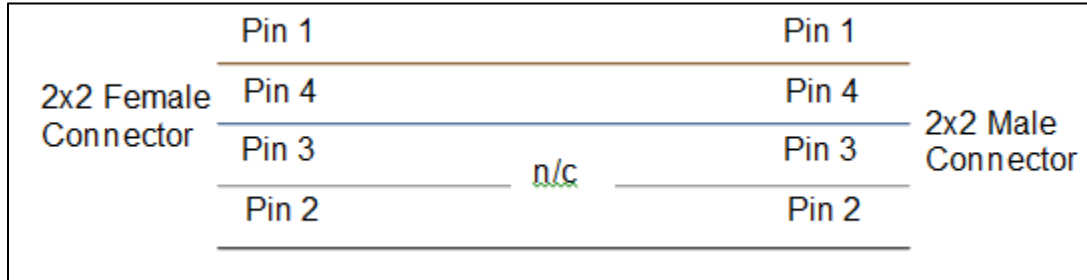
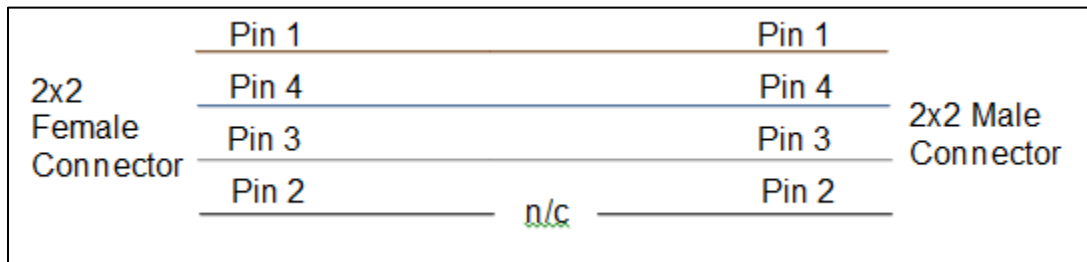

Figure 26: Slug Interrupt Wiring



16.2.1 Conveyor Power Supply

MHS Conveyor's power supplies feature a compact housing design that is designed specifically for use with CRUZcontrol logic modules.

These units meet the latest NEC Class II requirements in accordance with UL, EN, IEC standards. Installation is fast and easy due to slotted holes in a durable mounting plate that mounts directly to the side of the conveyor.

The power supplies are also capable of buffering brief power failure conditions at rated voltage (e.g., 20 ms at 120 VAC) in accordance with EN 60204-1. Global acceptance is also achieved by conformance with cULus standards (North American compliance) and CE standard requirements (European compliance).

Power Supply Features

- Adjustable output voltage up to 24...28 VDC
- 115/230 VAC or 480 2 phase VAC input
- State-of-the-art design
- Type 1 enclosure, IP 20
- Bolt on mounting

Figure 27: MHS Conveyor P/N 1117432 Dimensional Diagrams

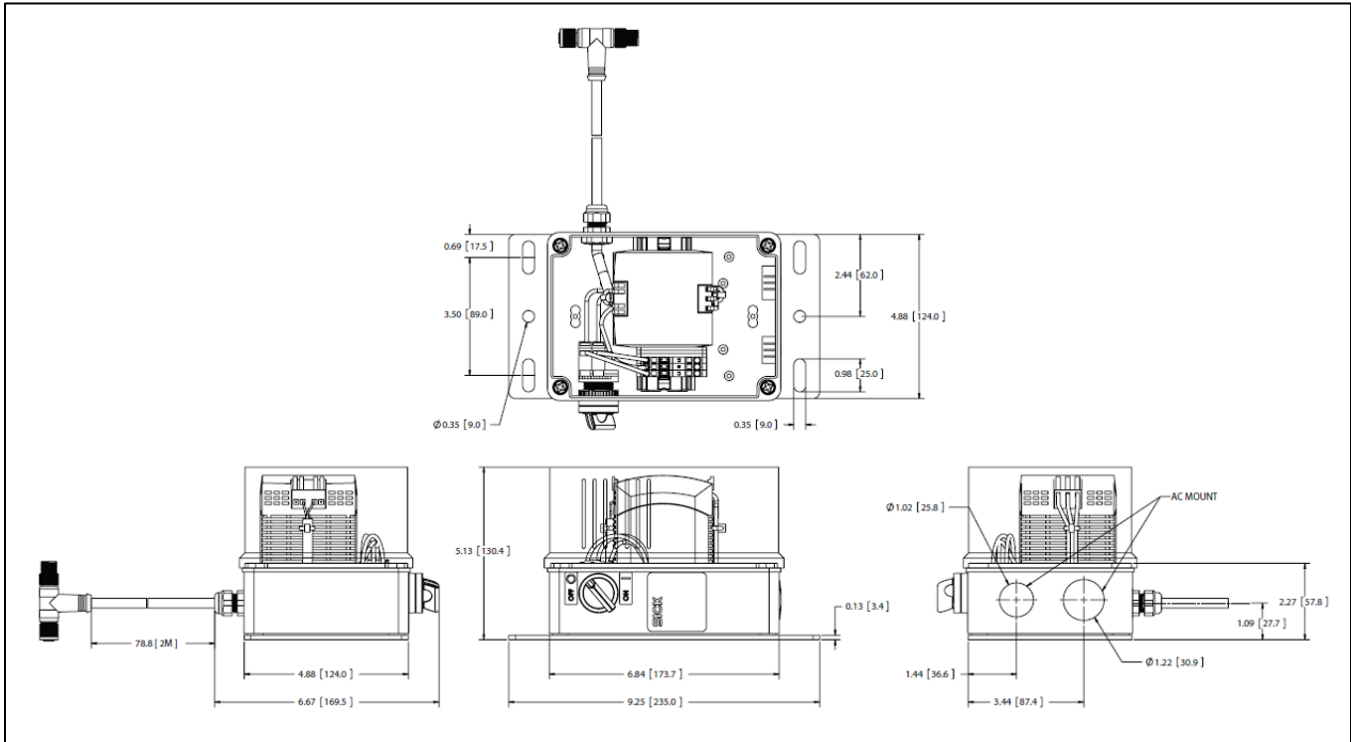

[Grab your reader’s attention with a great quote from the document or use this space to emphasize a key point. To place this text box anywhere on the page, just drag it.]

Figure 28: MHS Conveyor P/N 1117432 Connection Diagrams

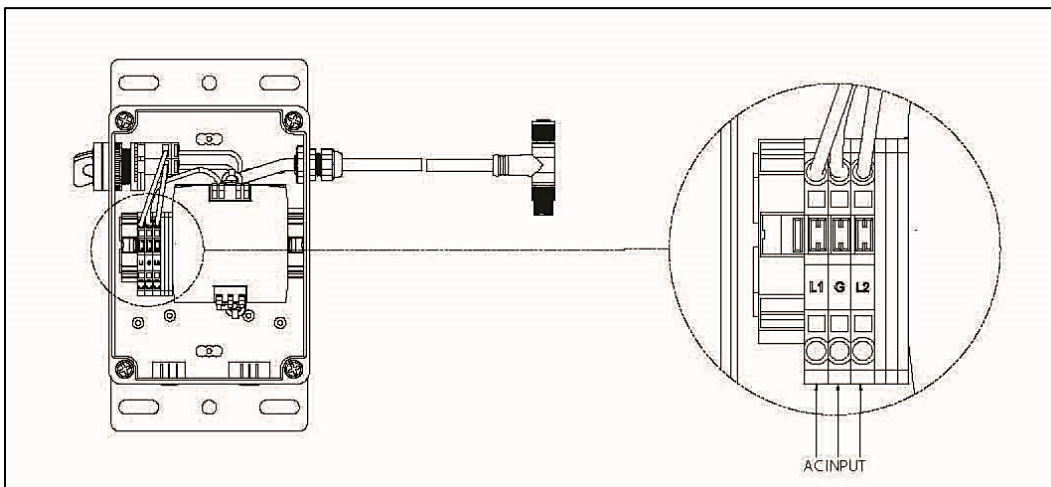

Figure 29: MHS Conveyor P/N 1117431 Dimensional Diagram

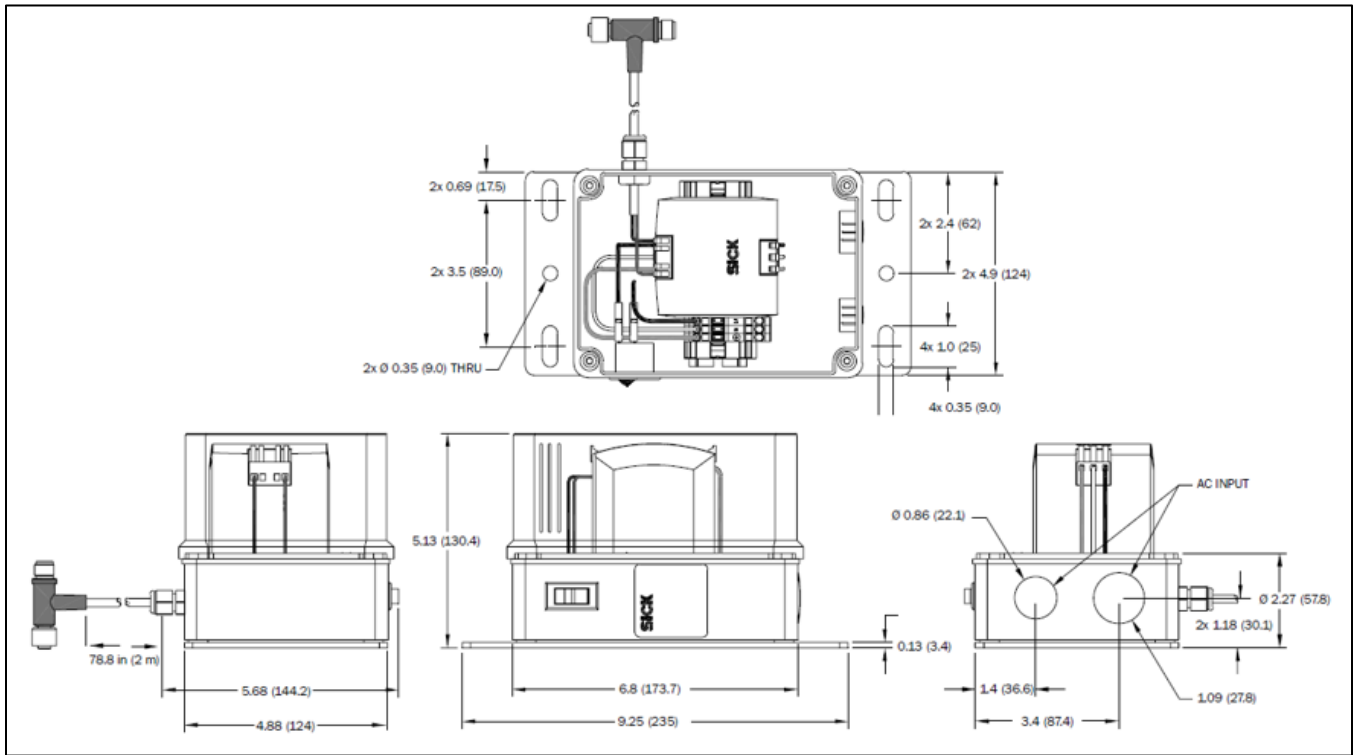
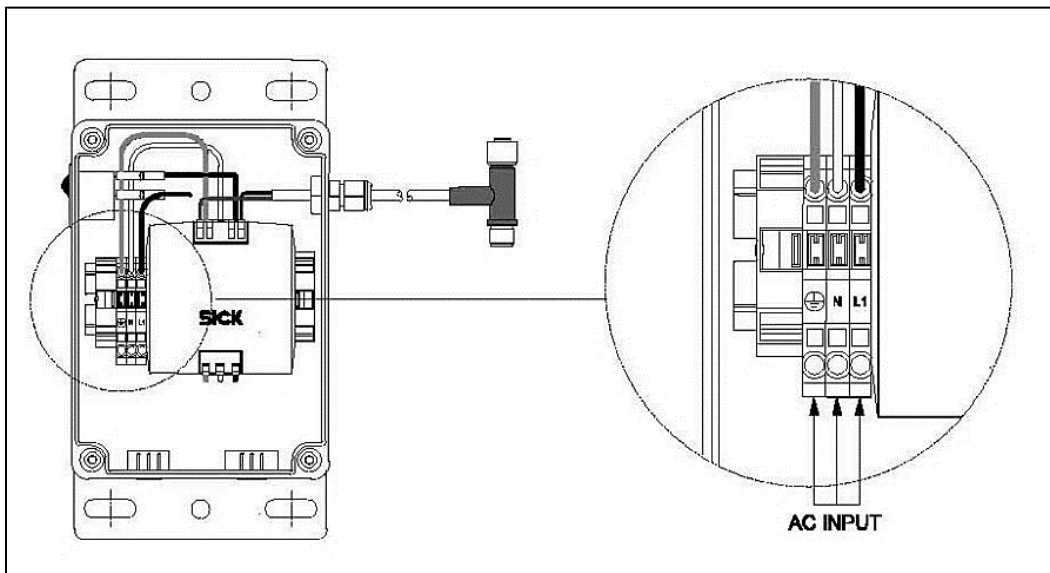

Figure 30: MHS Conveyor P/N 1117431 Connection Diagram



16.2.2 Power Supply Technical Data

Technical Data	PN 1117431	PN 1117432
Input Parameters		
Input Voltage Range V AC (nominal)	100...120/220...240 V	380...480 V (2 phase)
Input Voltage Range V AC (continuous)	85...132/184...264 V	323...552 V (2 phase)
Input Frequency	47...63 Hz	47...63 Hz
Phase	1	2
Input Voltage Range V DC (see derating requirements)	220...375 V	consult factory
Input Rated Current	< 2.0 A (100 V AC)	< 0.42 A (400 V AC)
	< 0.95 A (196 V AC)	< 0.36 A (480 V AC)
Transient Immunity Over Entire Load Range		Consult factory
Output Parameters		
Output Voltage	24...28 V DC	24...28 V DC
Output Voltage Preset	24.5 V DC ±0.5%	24.5 V DC ± 0.5%
Ripple/Noise @ 20 MHz, 50 Ohm	< 50 mVpp	< 50 mVpp
Output Voltage Regulation Accuracy	0.5% Vout static	± 200 mV static
	±1.5% Vout dynamic	Dynamic not available
Output Rated Current	3.9 A (at 24 V)	3.75 A (at 24 V)
	3.2 A (at 28 V)	3.2 A (at 28 V)
Hold Up Time	> 20 ms (196 V AC, 24.5V/3.9 A)	Typ. 52 ms (at 400 V)
	> 20 ms (100 V AC, 24.5 V/3.9A)	Typ. 93 ms (at 480 V)
General Device Parameters		
Operating Temperature Range (Tamb) - Full Load	14...140°F (-10...60 C)	14...140°F (-10...60 C)
Operating Temperature Range (Tamb) - Derated	122...140°F (50...60 C)	122...140°F (50...60 C)
Storage Temperature	-13...185°F (-25...85 C)	-13...185°F (-25...85 C)
Humidity (Do not energize when condensation is present)	< 93%	< 95%
Input Cable Access	3/4 or 1/2 in. hole for conduit	
AC Connection Wires		
Stranded cable	0.3...2.5 mm ² / AWG 28-12	≥ 2,5 mm ² , AWG 26-12
Solid cable	0.3...4 mm ² / AWG 28-12	≥ 2,5 mm ² , AWG 26-12
Stripping at wire end	6 mm	6 mm
<i>Note: secure wires from strain</i>		
AC External Protection/Fusing	20A Max	30A Max
Output Connector Cables	M12 4-pin "T" cable	M12 4-pin "T" cable
Efficiency	90% (typical at 230 V AC, 3.9A)	89.5% (at 400 V)
		89.0% (at 480 V)
Protection Class - Type 1 Enclosure	IP 20 (DIN/IEC 60 529)	IP 20 (DIN/IEC 60 529)
MTBF	500,000 h @ 40C SN 29500	1.5 Mio h @ 40C SN 29500
	Not tested at MIL 217 GP40	482,000 h @ MIL 217 GP40
Dimensions	9.25 x 5.67 x 5.13	9.25 x 5.67 x 5.13
	(235 x 144 x 130.4 mm)	(235 x 144 x 130.4 mm)
Weight	3.9 lbs (1.8 kg)	4.4 lbs (2.0 kg)
Cover Screw Torque Rating (in-lb)	4±1	4±1
Mounting	Vertical mounting only. AC input enters from the bottom	
Clearance	Keep 4 in. clearance from ventilating slots in cover	
Applicable Standards		
EN 60 950-1, IEC 60 950	Yes	Yes
EN 60 204-1, EN 50 178	Yes	Yes
Third Party Approvals		
UL 508 Listing (US and Canada)	Multiple Listing	Multiple Listing
UL 60 950-1 Recognition (US and Canada)	Multiple Listing	Multiple Listing
NEC Class 2 According to UL 1310	Multiple Listing	Multiple Listing

16.2.3 Part Number Listing

Table 18: Logic Module w/Sensor and 2x2 Daisy Chain

MHS Conveyor Part #	Description
1114947	Basic/Progressive, AtoB
1116736	Sensor/Valve Assembly, N.O. Valve
1116737	Basic/Progressive, AtoB, M12 Sensor Connection

Table 19: Accessories w/2x2 Connections

MHS Conveyor Part #	Description
1117370	Male Cordset
1117371	Female Cordset
1117372 1117373 1117374	Extension Cable, male-female, 1m Extension Cable, male-female, 2m Extension Cable, male-female, 4m
1117375	2x2-M12 Adapter, female-female
1117376	2x2-M12 Adapter, male-male
1117377	2x2-M12 Adapter, female-male
1117378	2x2-M12 Adapter, male-female
1117379	T-Cable (with flying leads), 2m
1117380	Power Interrupt Cable
1117381	Logic Interrupt Cable
1117382	Slug Interrupt Cable
1116731	Function Module, Full
1116732	Function Module, Release
1116733	Function Module, Zone Status

Table 20: Logic Module w/MHL1 Sensor and M12 Daisy Chain for CRUZcontrol

Part #	Description
E0001900A	Basic, AtoB
E0001901A	Basic, AtoD
E0001904A	Progressive, AtoB
E0001905A	Progressive, AtoD
E0005546	Basic, No Valve
E0006229	Sensor/Valve Assembly, N.O. Valve

Table 21: Accessories w/M12 Connections for CRUZcontrol

Part #	Description
ZPI-P1	Power Isolation Cable
ZLSI-P4	Slug Interrupt Cable
E0006304	Function Module, Full
E0006305	Function Module, Release
E0003613	Singulation Interrupt Cable

17 NBC MAINTENANCE & TROUBLESHOOTING

17.1 GENERAL PREVENTIVE MAINTENANCE



Periodic maintenance intervals shown may vary with load, speed, hours of daily operation, ambient temperature, humidity, etc. Intervals can be established by fairly frequent maintenance at first; then lengthen the intervals as justified by observation of need based on history. The following is based on 5 days per week, 8 hours per day under normal conditions.

Daily

- Listen to everything for unusual noises or vibration.
- Visually inspect to see that conveyor sections are clear and free of debris.
- Check to see that all safety guards are in place.
- Check any oil leakage.
- Check for loose bolts or parts.
- Check air filter bowls for accumulated water.
- Listen for air leaks.

Weekly

- Check belt tracking.
- Inspect bearings and gearmotors for excessive noise or heat.
- Check operation of all electrical controls.
- Check for proper PSI on air regulators.

 WARNING	
	<ul style="list-style-type: none"> • Prohibit riding on conveyor by anyone. • Think before making any adjustments. It may prevent an injury. Remember, all moving components are potentially dangerous. • Protect yourself from unexpected starts when working on a stopped unit by locking and tagging the control panel or disconnect switch that supplies power to the unit. • Lockout/Tagout procedures must be followed for every energy source of the conveyor.

Monthly

- Check air filters for cleanliness.
- Check drive unit for leaking seals and oil level in the gear case (if applicable), unusual noises, vibration, and stress cracks.

Semi-Yearly

- Inspect and clean motor control centers.
- Grease re-greasable bearings. *Recommend NLGI #2 lithium complex grease.*
- Check the belt welded splice for signs of premature failure.

Yearly

- Inspect oil in gearboxes.
- Inspect tightness of all nuts and bolts on units. Re-adjust and, if necessary, re-tighten.
- Check for plumb and level. Shims have been known to vibrate out from under supports in isolated incidents.
- Touch up paint that has been chipped. Unpainted surfaces will rust.
- Inspect for stress/fatigue cracks in frame and supports.

Welded Belt Splice Inspection

- Belt splice should be inspected every 2,000 hours.
- If belt splice is cracked or coming apart it should be scheduled as soon as possible for a new belt splice to replace the old belt splice.

CAUTION

- Check to confirm tools and foreign objects have not been left on or inside the conveyor.
- Check to confirm all loosened parts have been retightened.
- Check to confirm all guards have been installed.
- Never re-weld over old belt splice. This makes the belt splice weak and brittle.

Gearmotors



- NBC drive units use gearmotors which are properly filled at the factory with sufficient lubrication for their mounting position.
- A synthetic lube is the standard lube supplied. Refer to manufacture for details.

Disassembly/assembly procedure as follows

1. Remove necessary guards to access maintenance areas.
2. Disconnect any electrical connection.
3. Remove gearmotor.
4. Perform required maintenance.
5. Reverse procedures for assembly.
6. Replace all guards.



Regularly inspect all gearmotors to guarantee maximum performance.

1. Tightness of bolts and screws.
2. No major oil leaks.
3. No excessive heating.
4. No unusual vibration or noise.

 WARNING	
	<ul style="list-style-type: none"> • Do not perform maintenance on the conveyor until the startup controls are locked out and cannot be turned on by any person other than the one performing the maintenance. • If more than, one member of a crew is working on the conveyor, EACH CREW MEMBER MUST HAVE A LOCK ON THE POWER LOCK OUT. • The air pressure must be turned off to the work area. • All pneumatic devices must be de-energized to prevent accidental cycling of the device.

Solenoid Valves

In order to minimize downtime, it is normally not feasible to repair malfunctioning electrical or valve components while leaving the conveyor unusable. Spare components should be kept in stock for emergency replacement. If feasible, the part may be repaired later to replace maintenance stock. Items which cannot be readily repaired or are questionable should be replaced. Components under warranty should not be repaired except in an emergency.

 WARNING	
	<ul style="list-style-type: none"> • Before removing a valve or other pneumatic component, shut off and exhaust the entire pneumatic circuit and shut off and lockout electrical supply.

Sensing Switches

Sensing switches are of two types:

- retroreflective photoeye
- proximity switch

Adjust the retroreflective type as follows

1. Determine what sizes of target the photoeye must sense.
2. Adjust for the worst case, usually smallest item, by loosening photoeye mounting nut and aligning while making sure photoeye has unobstructed view of reflector.
3. Move the target in and out of the field of detection to ensure that the photoeye energizes and de-energizes.

Adjust the proximity type as follows

1. Loosen proximity switch mounting bolt and adjust sensing switch so that the product passes directly in front of the switch face, as close to the switch face as possible without making contact.
2. Check that the proximity switch energizes and de-energizes as the product passes in front of the switch face.
3. Tighten the mounting bolt.

17.2 TROUBLESHOOTING GUIDE – MECHANICAL/ELECTRICAL

Mechanical Problem	Possible Cause	Remedy
Insufficient drive	Rollers not turning consistently	Check alignment of pressure pan
	Poor bottom on product	Improve product convey ability
	Overloading of product	Remove overload
	Belt slippage	Check air pressure on take up assembly. Make sure belt tension is proper.
	Drive belt interference with structure	Locate and correct interference
	Belt installed wrong	Install belt properly
Rollers not turning/turning slowly	Belt not engaged with roller	Check alignment of pressure pan
	Zone not active	Check alignment of downstream photo eye
	Interference with roller or belt	Locate and correct interference
	Bent roller	Replace roller
Excessive Belt Wear	Poor routing of belt	Correct route of belt, ensure belt is woven through drive and end terminals correctly
	Interference within route of belt	Locate and correct interference issue
Belt out of groove. Or weakening of belt	High speed	Excessive speed in short conveyor units (under 70 linear feet) increases weld fatigue
	Maintenance Skew Section	If 4-foot middle section of intermediate bed is skewed in field, ensure belt is properly placed within pressure pan before roller installation (only section skewing allowed)

Mechanical Problem	Possible Cause	Remedy
Items not accumulating	Lack of power	Ensure power supply is functioning properly
	Improper wiring of T-cable to power supply	Only the brown and blue wires of the T-cable are used to connect with the Power Supply. If the white and black wires connect in any way... the logic is turn into progressive mode out of singulation, and all function module settings are overridden
	Broken logic module	Located module and replace with new component
	Lack of air	Ensure Filter Regulator is functioning properly and is set at proper setting. (40psi)
Zones not releasing	Cable connector issue	Ensure proper connection, check for damage.

18 NBC REPLACEMENT PARTS IDENTIFICATION

This section is used to identify parts that may require replacement during the life of the conveyor. Parts, which specifically pertain to MHS Conveyor conveyors, are included with illustrations. A "Recommended Spare Parts List" is published for all conveyor orders of \$20,000. This spare parts list is sent to the purchaser approximately (2) weeks after the order is received. It includes part numbers, description, pricing and recommended quantities to be kept on hand for maintenance. If you are unable to locate this document, another may be obtained by contacting the MHS Conveyor Lifetime Services at 231-798-4547.

18.1 SPARE PARTS PRIORITY LEVEL EXPLANATIONS

Level #1

Failure of a priority level #1 spare parts ("A" level part) may cause major disruption of system performance.

Priority level 1 spare parts must be on-hand, and available to be replaced in the event of a component failure that could shut down a critical function of a conveyor system.

Priority level 1 spare parts include motors, gear reducers, gearmotor, motorized rollers, air solenoid valves, and related components. The majorities of these parts are purchased from MHS Conveyor vendors and carry their own warranties through these vendors. For more warranty information, see MHS Conveyor Equipment Warranty.

Level #2

Failure of a priority level #2 spare parts ("B" level part) usually is gradual and should not cause a major system disruption.

Priority level 2 spare parts are parts required for smooth system operation and preventative or regular mechanical maintenance.

Priority level 2 spare parts include roller chain, sprockets, belt pulleys, rollers, air cylinders, and other related parts whose failure should not stop a conveyor system suddenly. These parts tend to wear out gradually and are not known to fail suddenly.

Level #3

Priority level #3 parts ("C" level part) rarely fails and are easily obtainable.

Priority level 3 spare parts are parts that rarely fail or maybe optionally used by the customer.

18.2 NBC 500-AT Drive Assembly

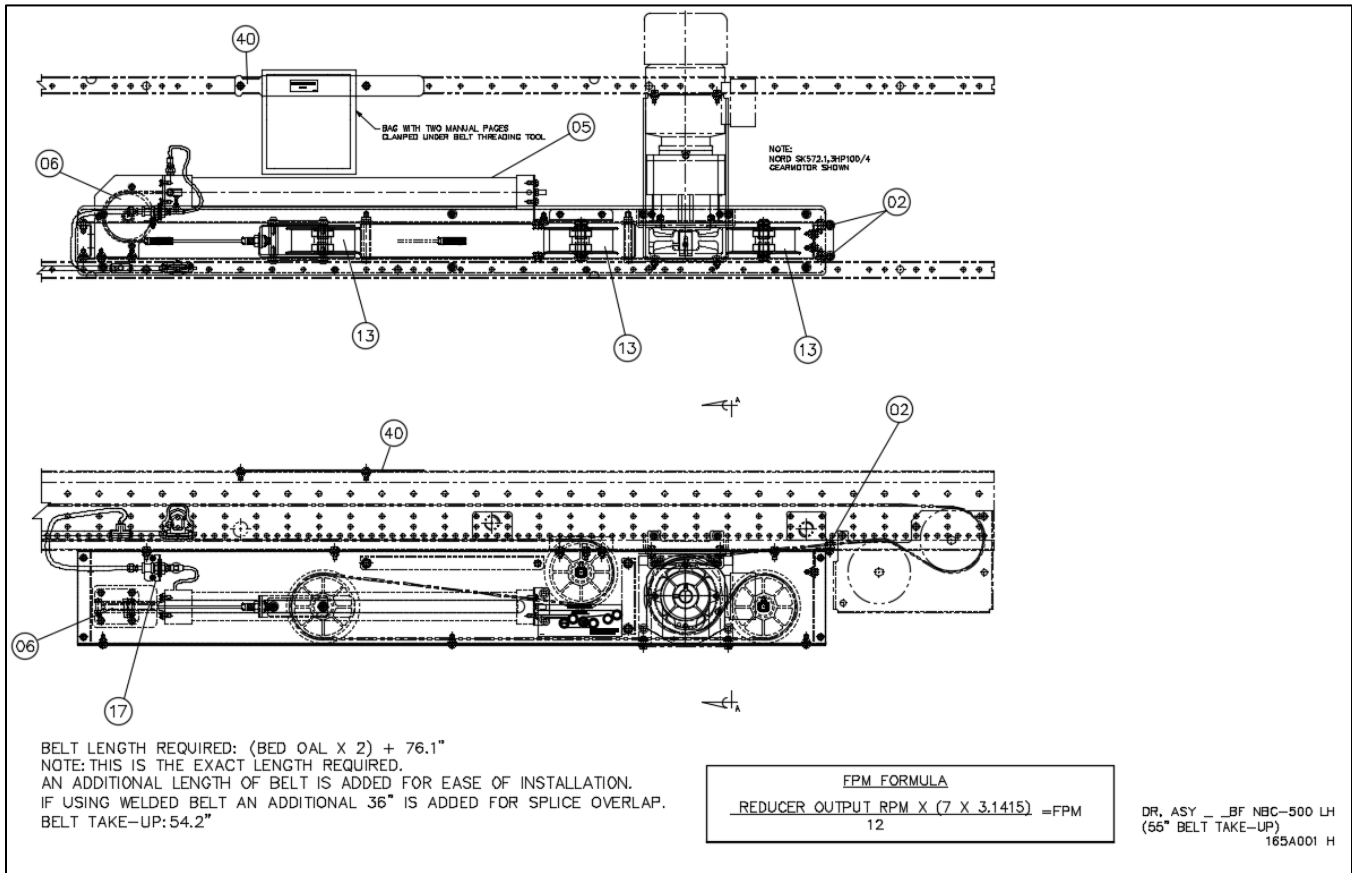

18.2.1 Replacement Parts - NBC 500-AT Drive Assembly

REPLACEMENT PARTS - NBC 500 LB AT DRIVE					
DR-ASY,NBC-28BF-500AT-LH		Width & Item #			
Balloon	Description	16 BF	22 BF	28 BF	34 BF
--	GEARMOTOR	SEE CHART	SEE CHART	SEE CHART	SEE CHART
--	DRIVE PULLEY	SEE CHART	SEE CHART	SEE CHART	SEE CHART
06	PULLEY,CABLE 1/4" WIDE X 5" OD	1121143	1121143	1121143	1121143
02	BEARING, R6ZZ C3	90050111	90050111	90050111	90050111
05	CYLINDER, 2.5" BORE X 28" STK W/ CABLE	1103837	1103837	1103837	1103837
13	PULLEY, ASY 6" W/FLANGE	E0002214	E0002214	E0002214	E0002214
17	ASY,AIR VALVE NBC 3/8" IN - 1/4" OUT	1117620	1117620	1117620	1117620
40	TOOL,NBC BELT THREADING & INSTRUCTIONS	1119143	1119143	1119143	1119143

REF DWG# 165A001H

18.3 NBC 500-AT AIR TAKE-UP

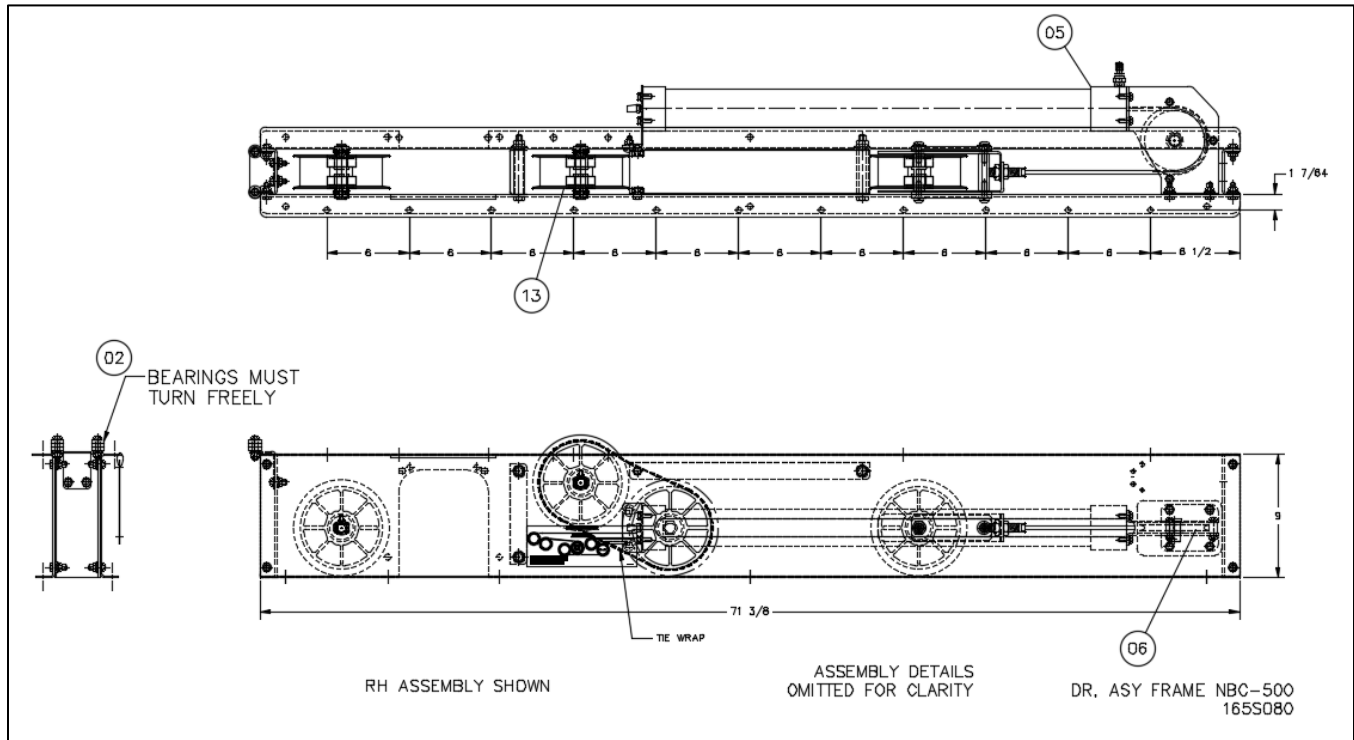

18.3.1 Replacement Parts - NBC 500-AT Air Take-Up

DRIVE ASSEMBLY - NBC 500-AT Air Take-Up					
DR-ASY,NBC-28BF-500AT-LH		Width & Item #			
Balloon	Description	16 BF	22 BF	28 BF	34 BF
5	CYL,CABLE 2.5"B X 28S MOD	1103837	1103837	1103837	1103837
6	PULLEY,CABLE 1/4"W X 5"OD	1121143	1121143	1121143	1121143
2	BRG, R6 ZZ C3	90050111	90050111	90050111	90050111
13	PULLEY,ASY 6"DIA W/FLANGE	E0002214	E0002214	E0002214	E0002214

REF DWG# 165S080

18.4 NBC 500-AT DRIVE TRAIN

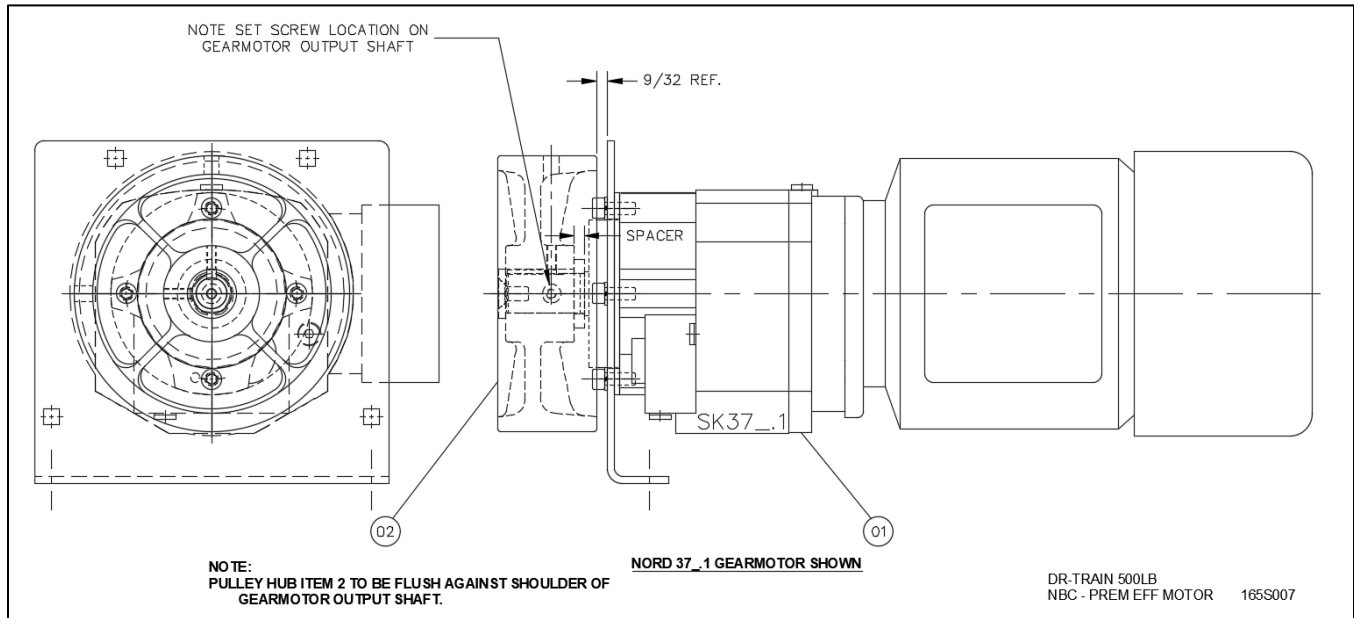

18.5 REPLACEMENT PARTS - NBC 500 DRIVE TRAINS

NBC 500# DRIVE TRAINS						
NOMINAL	DRIVE TRAIN P/N	GEARMOTOR P/N	MOTOR	REDUCER SIZE	PULLEY	BORE IN INCHES
FPM	ITEM 01	ITEM 01	HP	ITEM 01	ITEM 02	ITEM 02
105	1117672	1117638	1	SK572.1/80LP	1191846	1-1/4"
125	1117674	1117640	1	SK372.1/80LP	1120871	1"
130	1117676	1117642	2	SK572.1/90LP	1191846	1-1/4"
165	1117681	1117647	2	SK572.1/90LP	1191846	1-1/4"
250	1214999	1214992	3	SK572.1/100LP	1191846	1-1/4"

Ref DWG# 165S007

18.6 NBC PRESSURE ASSEMBLY

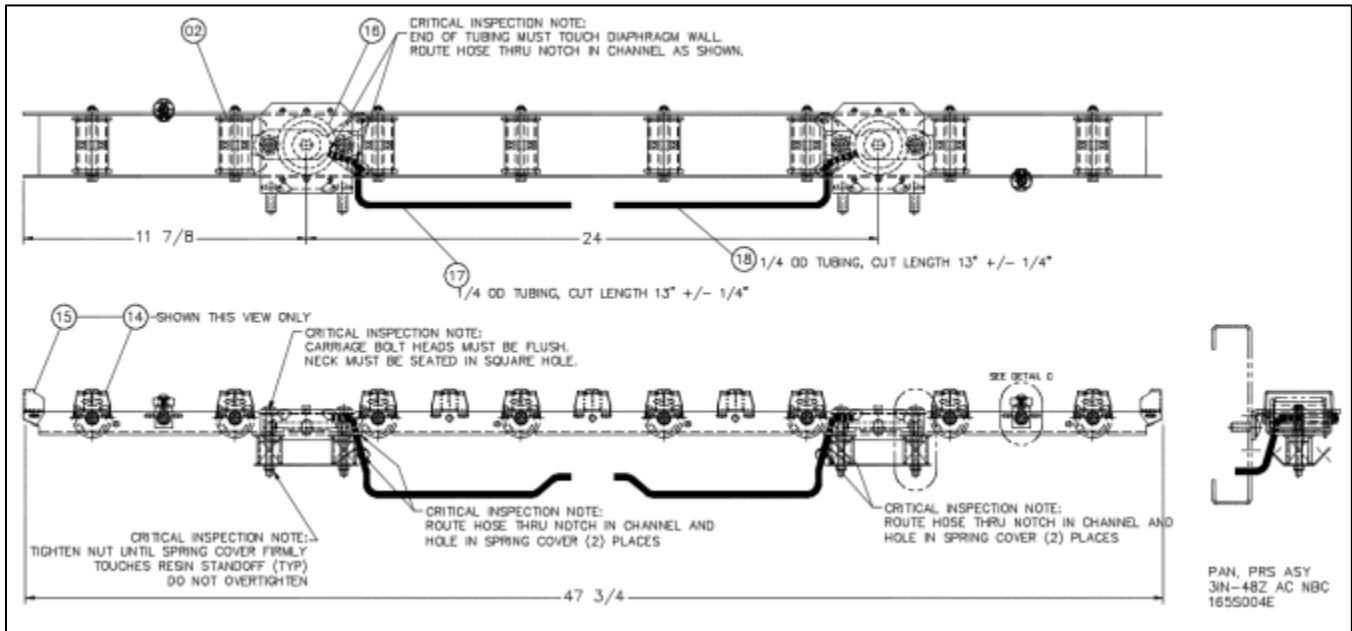

18.6.1 Replacement Parts - NBC Pressure Pans Assembly

REPLACEMENT PARTS - NBC PRESSURE PAN ASSEMBLY					
PAN, PRS ASY 3IN-48Z AC NBC		Width & Item #			
Balloon	Description	16 BF	22 BF	28 BF	34 BF
2	ROLLER,PRESSURE NBC	1109203	1109203	1109203	1109203
14	CLIP,BELT COVER,MIDDLE NBC	1113596	1113596	1113596	1113596
15	CLIP,BELT COVER,END NBC	1113597	1113597	1113597	1113597
16	DIAPHRAGM,ASY PNEUMATIC 1 AIR	60710000	60710000	60710000	60710000
17 & 18	TUBING,1/4" PLYU-90DUR X 13"	89000580	89000580	89000580	89000580
REF DWG# 165S004E					

18.7 NBC SKEWED PRESSURE PAN ASSEMBLY

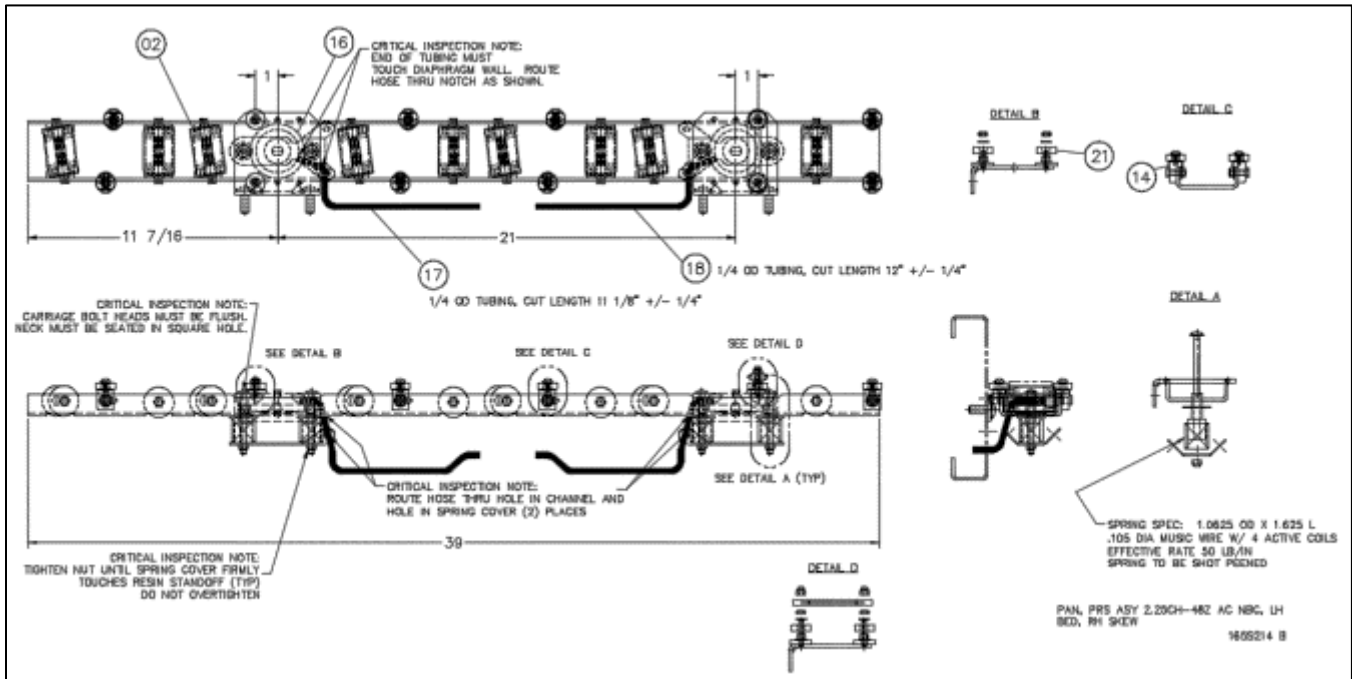

(LH bed, RH skew shown)

18.7.1 Replacement Parts - NBC Skewed Pressure Pan Assembly

REPLACEMENT PARTS - NBC SKEWED PRESSURE PAN ASSEMBLY					
PAN, PRS ASY 2.25CH-48Z AC NBC LH BED, RH SKEW		Width & Item #			
Balloon	Description	16 BF	22 BF	28 BF	34 BF
2	ROLLER, PRS NBC W/ AXLE	1118018	1118018	1118018	1118018
14	ASY, BELT GUIDE BRKT NBC SKEW PAN	1132973	1132973	1132973	1132973
16	DIAPHRAGM, ASY PNEUMATIC 1 AIR	60710000	60710000	60710000	60710000
17	TUBING, URETHANE .250OD, .159ID	89000580	89000580	89000580	89000580
18	TUBING, URETHANE .250OD, .159ID	89000580	89000580	89000580	89000580
21	BEARING, R6ZZ	90050111	90050111	90050111	90050111

REF DWG# 165S214B

18.8 NBC DISCHARGE BRAKE ASSEMBLY

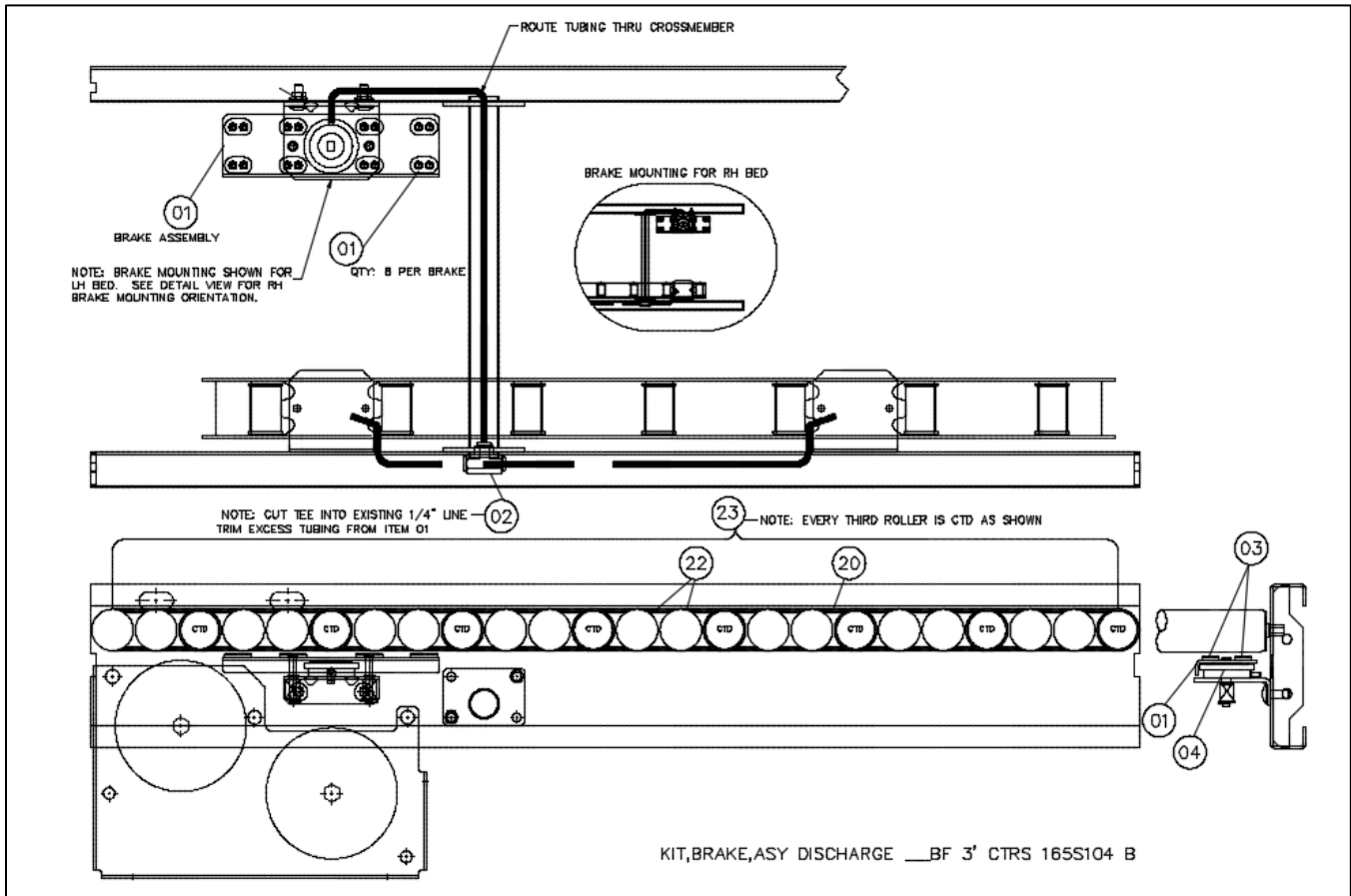

18.8.1 Replacement Parts - NBC Brake Assembly

REPLACEMENT PARTS - NBC BRAKE ASSEMBLY					
KIT,NBC-__BF-3RC OR 2RC-CTD RLR-BRAKE		Width & Item #			
Balloon	Description	16 BF	22 BF	28 BF	34 BF
01	BRAKE ASSEMBLY	1117955	1117955	1117955	1117955
02	FITTING,UNION TEE 1/4" T	89000530	89000530	89000530	89000530
03	BUMPER, BRAKE PAD	1113368	1113368	1113368	1113368
04	DIAPHRAGM, ASY PNEUMATIC SINGLE STEM	60710000	60710000	60710000	60710000
20	ORING, 83A ST TRNS 3/16" X 9-15/16	90530005	90530005	90530005	90530005
22	ROLLER, ITR 1.9PLTD PRBG	E0002412	E0002413	E0002414	E0006220
23	ROLLER, PLASTIC COAT 2D 1.9CTD - 3" RC	1119631	1119632	1119633	1119634
----	ROLLER, PLASTIC COAT 2D 1.9CTD - 2" RC	1127420	1127421	1127422	1127423
----	BRAKE KIT ASY, INCLUDES ROLLERS - 3" RC	1118098	1118099	1118100	1118101
----	BRAKE KIT ASY, INCLUDES ROLLERS - 2" RC	1129547	1129548	1129549	1129550

Dwg# 165S104B

18.9 NBC END PULLEY ASSEMBLY

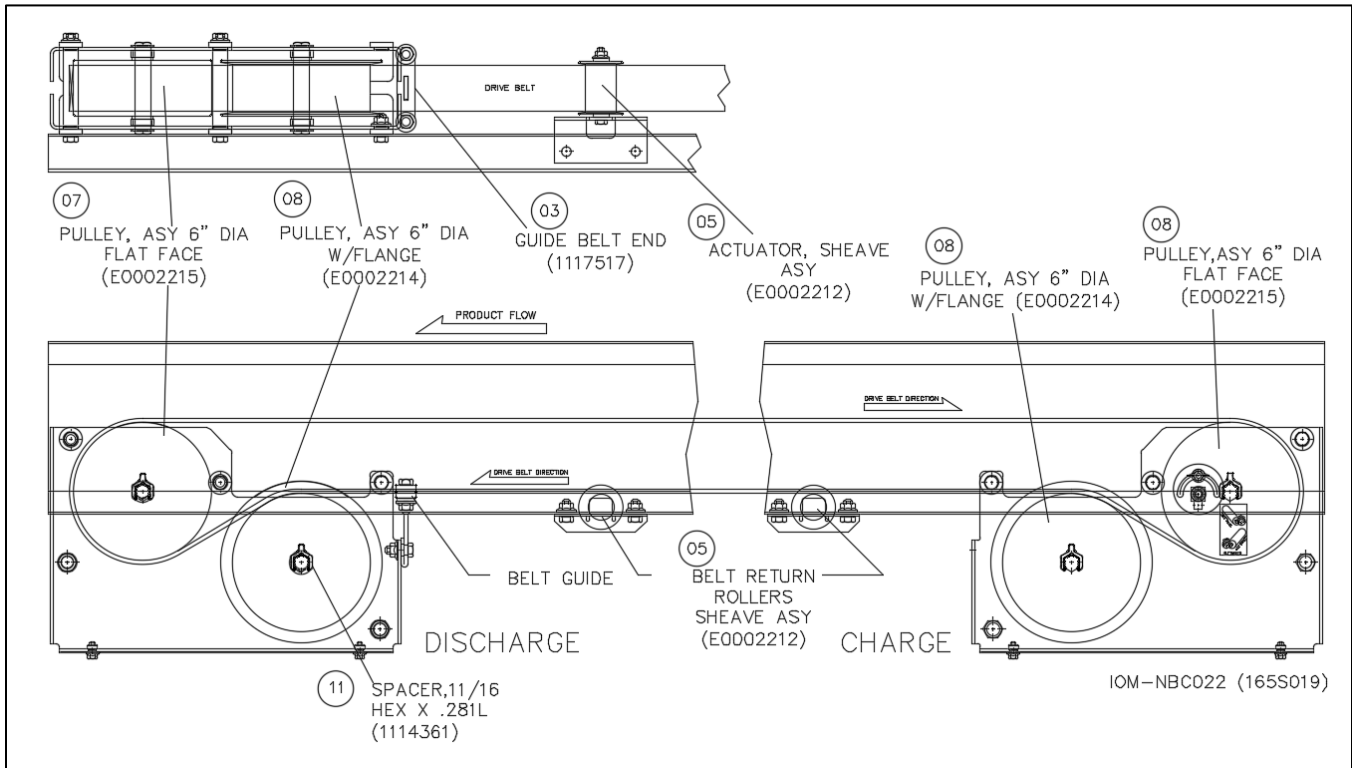

(Charge / Discharge)

18.9.1 Replacement Parts- NBC Terminal Pulley

REPLACEMENT PARTS - NBC TERMINAL PULLEY						
ASY, TERMINAL PULLEY NBC		Width & Item #				
Balloon	Description	16 BF	22 BF	28 BF	34 BF	
07	PULLEY, ASY 6" DIA FLAT FACE	E0002215	E0002215	E0002215	E0002215	E0002215
08	PULLEY, ASY 6" DIA W/FLANGE	E0002214	E0002214	E0002214	E0002214	E0002214
05	ACTUATOR, SHEAVE ASY	E0002212	E0002212	E0002212	E0002212	E0002212
03	GUIDE, BELT END NBC	1117517	1117517	1117517	1117517	1117517
11	SPACER, 11/16 HEX X .281L	1114361	1114361	1114361	1114361	1114361

Dwg# 165S019

18.10 NBC 12 FT. CONTACT ACCUMULATION

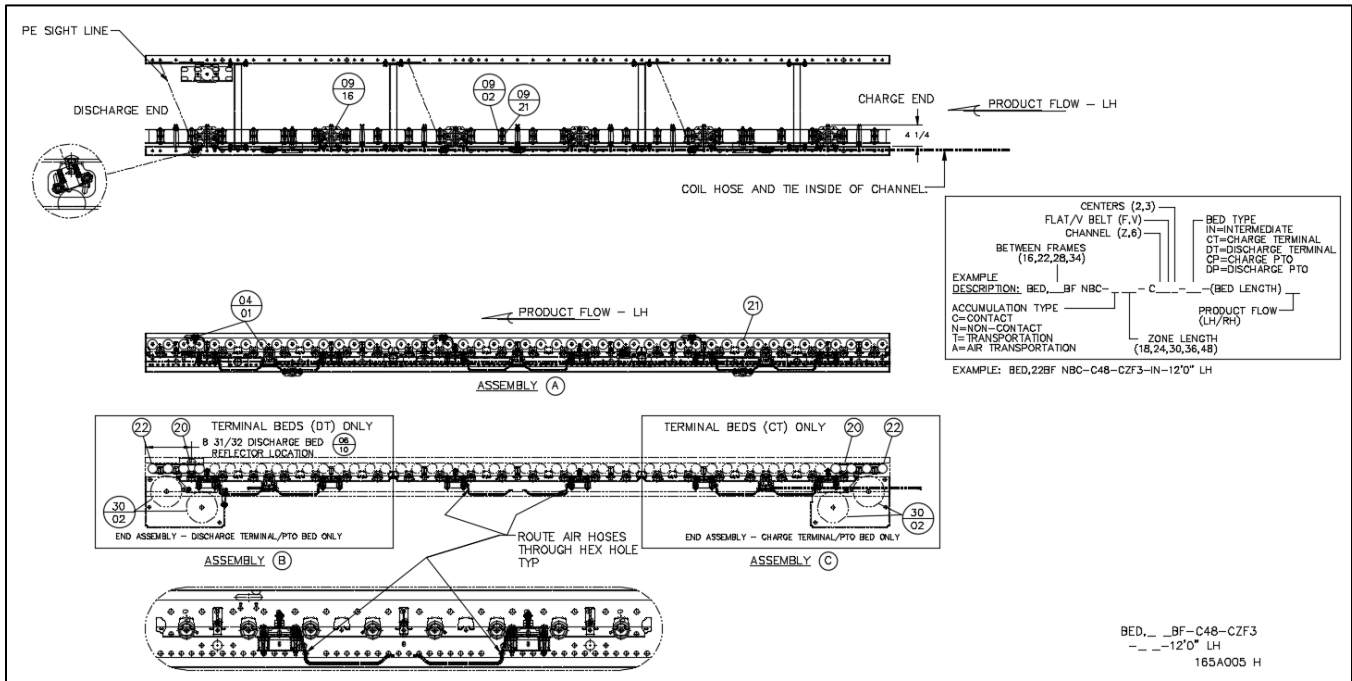

(LH bed shown)

18.10.1 Replacement Parts - NBC Contact Accumulation

REPLACEMENT PARTS - NBC CONTACT ACCUMULATION					
BED,NBC- _BF-C48-IN-CZ-2rc OR 3RC-LH/RH		Width & Item #			
Balloon	Description	16 BF	22 BF	28 BF	34 BF
----	HARNESS,ASY NBC 48" 3 ZONE LH ATB	----	----	----	----
04/01	LM,ASY AIR TO BRAKE W/PE BRKT & HDWE	1115898	1115898	1115898	1115898
----	PE,REFLECTOR W/ FOAM TAPE HORIZONTAL MOUNTED	----	----	----	----
06/10	PE,REFLECTOR 4-3/8" X 1-1/8"	400004	400004	400004	400004
----	ASY,RETURN ROLLER NBC	----	----	----	----
30/02	ACTUATOR,SHEAVE ASY	E0002212	E0002212	E0002212	E0002212
----	STANDOFF,ACTUATOR,SHEAVE ASY	E0002213	E0002213	E0002213	E0002213
-----	PAN,PRS ASY	----	----	----	----
09/02	ROLLER,PRESSURE NBC	1109203	1109203	1109203	1109203
09/16	DIAPHRAGM,ASY PNEUMATIC 1 AIR SINGLE AIR INLET	60710000	60710000	60710000	60710000
----	TUBING,URETHANE .250OD,.159ID	89000580	89000580	89000580	89000580
09/21	BRG, R6 ZZ C3	90050111	90050111	90050111	90050111
----	BED,NBC- _BF	----	----	----	----
20	ORING,83A ST TRNS 3/16X9-15/16	90530005	90530005	90530005	90530005
21	ROLLER, "GRAV 1.9 PLTD PRBG	60218009	60224009	60230009	60236009
22	ROLLER, _ITR 1.9PLTD PRBG	E0002412	E0002413	E0002414	E0006220
----	HOSE, CLEAR	----	----	----	----
----	TUBING,POLYETHYLENE 3/8 OD,CLR	89000585	89000585	89000585	89000585

Dwg# 165A005

18.11 NBC Logic Module Component

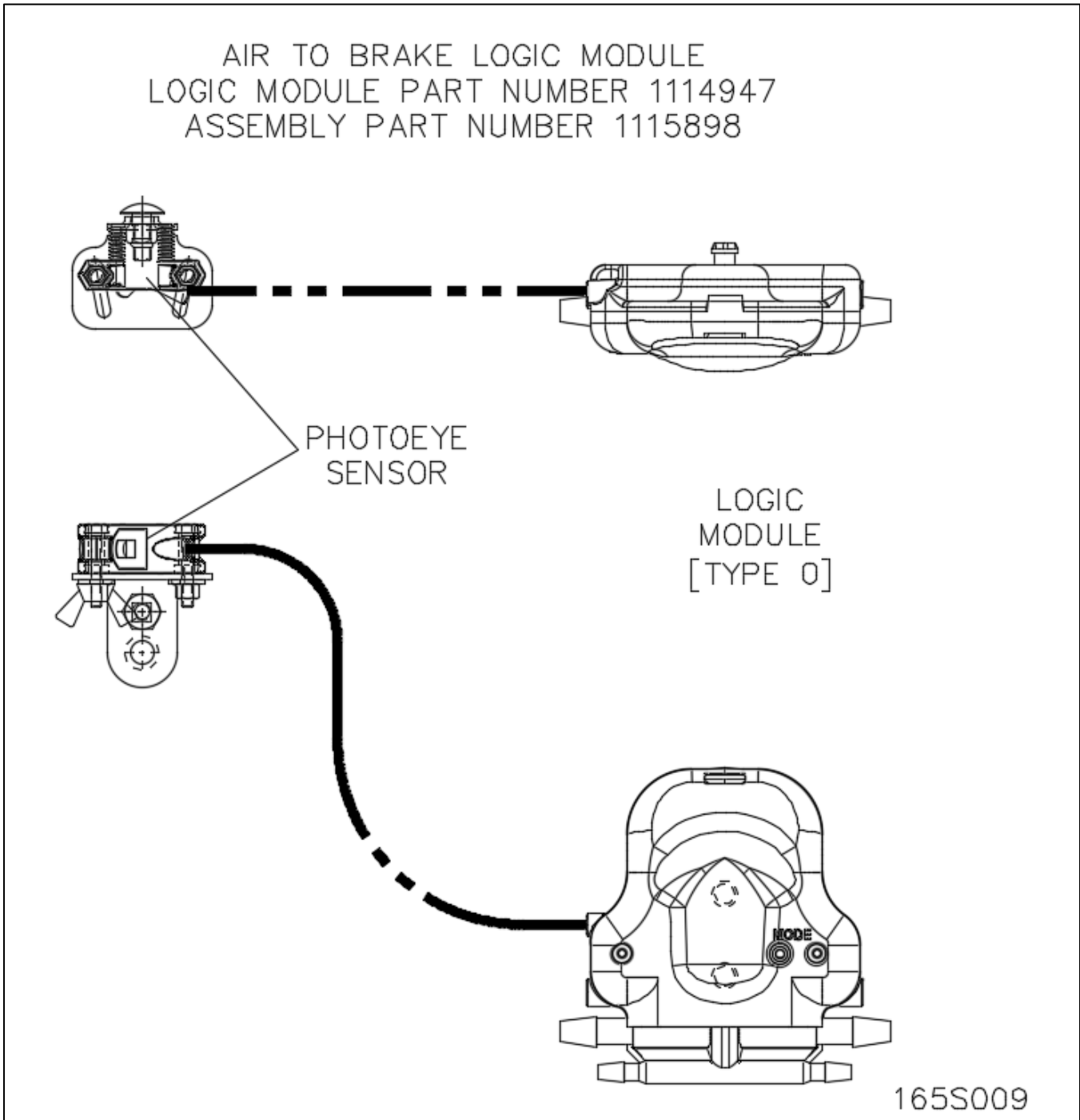

Air to brake logic module - Straight Beds

18.12 NBC 12 FT. CONTACT ACCUMULATION SKEWED ROLLERS

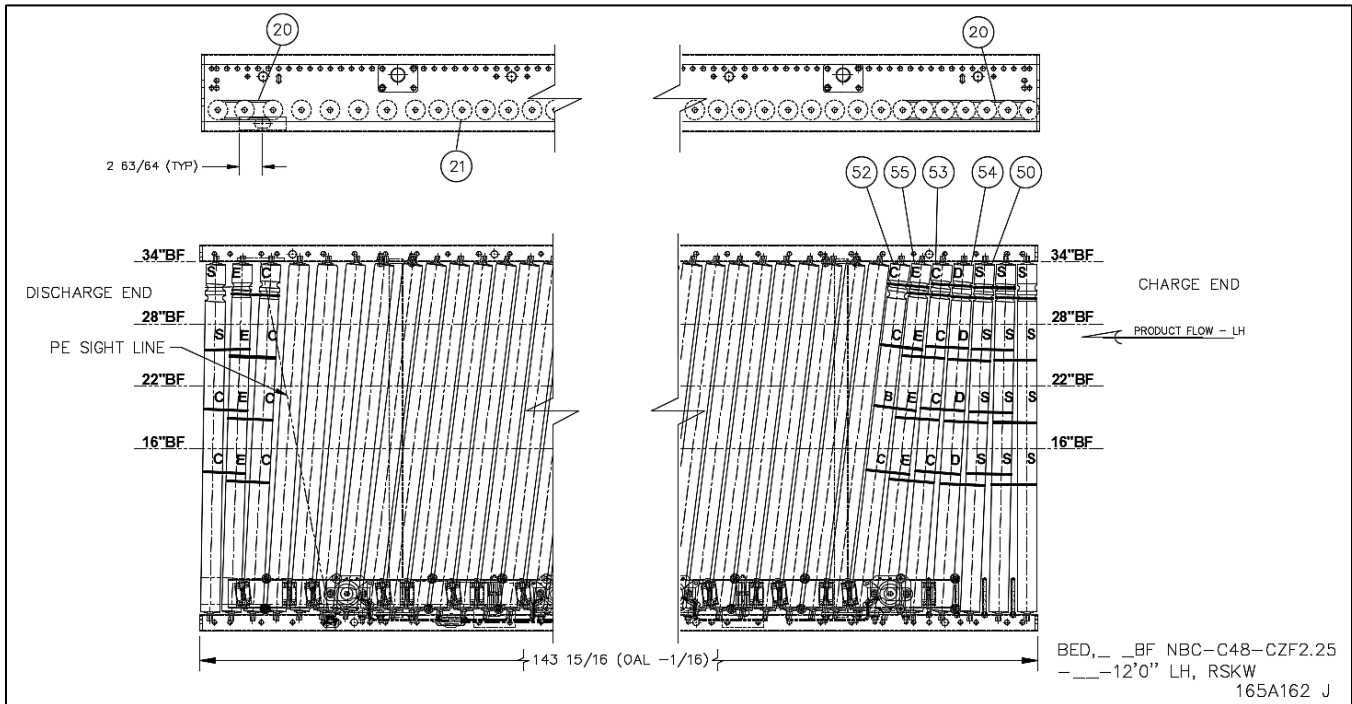

(LH Bed with RH Skew shown)

18.12.1 Replacement Parts - NBC 12ft Contact Accumulation Skewed Rollers

Replacement Part Numbers for NBC Contact Accumulation Skewed Rollers (LH Bed with RH Skew Shown)						
BALLOON	ROLLERS	QTY	16BF	22BF	28BF	34BF
21	NO GRVS	53	1154835	1154836	1154837	1154838
50	S	3,3,4,4	1154831	1154832	1154833	1154834
52	B	1	---	1121728	---	---
53	C	4,3,3,3	1118554	1121729	1118079	1119832
54	D	1	1118555	1121730	1118080	1119833
55	E	2	1118557	1121731	1118086	1119834
BALLOON	ITEM #	QTY	DESCRIPTION			
20	90530003	8	ORING,83A CURVE TRNS. 3/16"X9"			

Dwg# 165A162H

18.13 NBC 12 FT. CONTACT ACCUMULATION SKEWED ROLLERS

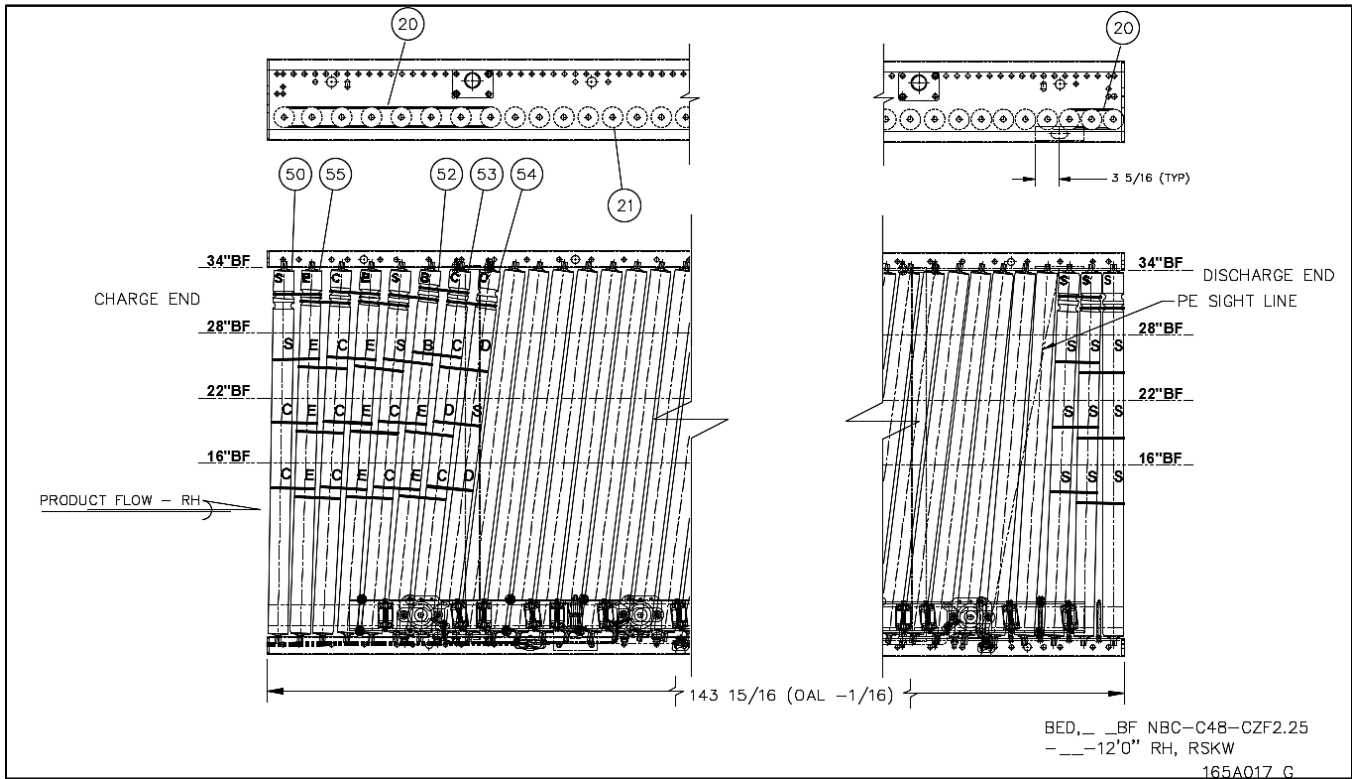

(RH Bed with RH Skew shown)

18.13.1 Replacement Parts - NBC 12ft Contact Accumulation Skewed Rollers

Replacement Part Numbers for NBC Contact Accumulation Skewed Rollers (RH Bed with RH Skew Shown)						
BALLOON	ROLLERS	QTY	16BF	22BF	28BF	34BF
21	NO GRVS	52	1154835	1154836	1154837	1154838
50	S	3,4,5,5	1154831	1154832	1154833	1154834
52	B	1	---	---	1118078	1119831
53	C	4,3,2,2	1118554	1121729	1118079	1119832
54	D	1	1118555	1121730	1118080	1119833
55	E	3,3,2,2	1118557	1121731	1118086	1119834
BALLOON	ITEM #	QTY	DESCRIPTION			
20	90530003	9	ORING,83A CURVE TRNS. 3/16"X9"			

Dwg# 165A017G

NBC REVISION HISTORY

Revision Date	Chapter and Description	Initials
06/18/2021	New Spanish IOM available	AB / MD
06/18/2021	Added new packaging & part location for skew section	MM
09/28/2021	Add MHS Conveyor name, logo, and format	MD AB
12/2/2021	Updated Drive train spare parts list & add belt tracking to weekly maintenance inspection	AB / MW
02/28/2022	Updated part list to DWG 165S007	DG / MD
08/01/2022	Removed skew packaging location for skew beds.	DG
01/24/2023	Removed 250-AT Drive and Drivetrain. Update belt weld overlap information. Updated some pictures.	AB, BK

WORKS CITED

- AISC. (2015). *American Institute of Steel Construction*. Retrieved 1 14, 2015, from <https://www.aisc.org/>
- ANSI. (2013-2014). *American National Standards Institute*. Retrieved 2014, from ANSI Standards Store: <http://www.ansi.org/>
- ASME. (2014). *The American Society of Mechanical Engineers*. Retrieved 12 05, 2014, from <https://www.asme.org/>
- CEMA. (2014). *Conveyor Equipment Manufacturers Association*. Retrieved 2014, from Conveyor Equipment Manufacturers Association: <http://www.cemanet.org/>
- Nitta Inventions & Innovation. (2022, 10 11). *Nitta Inventions & Innovation*. Retrieved from <https://www.nitta.com/>: <https://www.nitta.com/>
- Nord. (2015). *Nord Drivesystems*. Retrieved from Nord Drivesystems: <https://www.nord.com/cms/us/home-us.jsp>
- OSHA. (2014). *Occupational Safety & Health Administration*. Retrieved 2014, from OSHA QuickTakes: <https://www.osha.gov/>

GENERAL MHS CONVEYOR

Para obtener manuales, videos y otros recursos adicionales, visite nuestro sitio web en:

www.mhs-conveyor.com

ABOUT MHS CONVEYOR

About MHS Conveyor

MHS Conveyor, located in Norton Shores, Michigan, is a leading deliverer of “smart” material handling systems, technologies, products, and services, creating solutions for material flow applications. As a global supplier of conveyor systems and equipment since 1964, MHS Conveyor provides sorters, conveyors, and accessories to satisfy a broad spectrum of accumulation, transportation, and sortation applications.



MHS Conveyor Corp.
1300 E. Mount Garfield Road
Norton Shores MI 49441-6097 USA
231.798.4547
Email : usinfo@mhs-conveyor.com
Web Site : mhs-conveyor.com



Regional sales offices and authorized Business Partners located throughout the United States and Canada. Licensees and Business Partners in Europe, South America, and Southeast Asia.