

APPLICATION CONTROL GUIDELINES



IntelliROL® to NBC™ Transition

P/N: 1180736

Revision Date: June 8, 2023



CONTENTS

MHS SAFETY RECOMMENDATION	3
WARNINGS AND SAFETY INSTRUCTIONS	4
TYPE 1 CBM-105 UPSTREAM SLAVE TO NBC - LOCAL ACCUMULATION CONTROL	5
1.1: PRESSURE SWITCH ASSEMBLY	6
1.2: TYPE 2 CBM-105 DOWNSTREAM SLAVE TO NBC - ACCUMULATION CONTROL.....	7
1.3: ACCUMULATION CURVE	8
TYPE 3 NO LONGER APPLICABLE.....	9
TYPE 4 NBC TO HB-510 MOTORIZED ROLLER - LOCAL ACCUMULATION CONTROL.....	10
1.4: FIELD WIRING CRUZCONTROL TO ITR TRANSITION	11
WORKS CITED	12
MHS CONVEYOR GENERAL INFORMATION.....	12
ABOUT MHS CONVEYOR.....	13

MHS SAFETY RECOMMENDATION

For additional safety information: MHS agrees to the following safety instruction or guidelines listed within this manual. This is not to conflict with your state or legal requirements.

MHS recommends for maintenance or repair purposes, to incorporate a lock out and tag procedure to ensure all starting devices, prime movers (Pneumatic), or powered accessories are off before attempting maintenance or repair.

The following procedures are designed to protect everyone involved with the conveyor against an unexpected restart, which includes understanding of potential hazard of stored energy, which can exist after the power source is locked out.

For additional information, refer to the latest issue of ANSI Z244.1, American National Standard for Personnel Protection – Lockout/Tagout of Energy Sources– Minimum Safety Requirements.

<http://www.ansi.org/>



OSHA 29CRF Part 1910.147 *“Control of Hazardous Energy Sources (Lockout/Tagout)”*, which includes requirements for release of stored energy and OSHA Safety and Health Regulations for Construction 1926.555 Conveyors <https://www.osha.gov/>

WARNINGS AND SAFETY INSTRUCTIONS

Failure to follow the instructions and cautions throughout this manual and warning label on the conveyor may result in injury to personnel or damage to the equipment.

Your MHS conveyor is powered by a motor and can be stopped only by turning off electrical power to the motor. As with all powered machinery, the drive-related components – including sprockets, chains, shafts, universal joints, and pneumatic devices – can be dangerous. We have installed or provided guards to prevent accidental contact with these parts, along with warning labels to identify the hazards.

Special attention must be paid to the following areas of this manual:

 WARNING	
	<ul style="list-style-type: none">• Indicates a potentially hazardous situation, which, if not avoided, could result in death or serious injury.

CAUTION	
<ul style="list-style-type: none">• Indicates a situation, which, if not avoided, could result in property damage.	



Safety: Always lock out power source and follow recommended safety procedures.

TYPE 1 CBM-105 UPSTREAM SLAVE TO NBC - LOCAL ACCUMULATION CONTROL

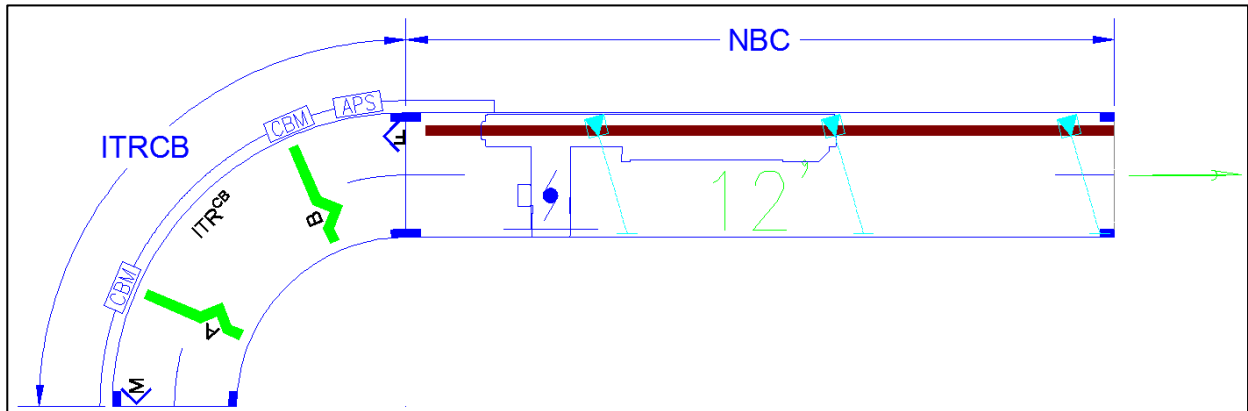

Use When

- NBC is fed by a curve

Benefits

- Curve acts as an extension of the last NBC zone
- Eliminates PLC wiring for line full, curve stop and upstream conveyor release
- Eliminates programming to keep the curve clear
- All local, low voltage logic and wiring
- Much higher product throughput than traditional PLC logic and wiring
- Allows additional NBC upstream with no PLC control

Requirements

- Need power supply for motorized roller curve to shut off under system stop and E-stop conditions
- CRUZcontrol extension cable to pass logic around curve if there is NBC upstream
- Brake zone in upstream NBC discharge if present

How to Order

- P/N 1152538, pre-mount to curve
- P/N 1152711, kit for field installation
- CRUZcontrol extension cables and upstream NBC zone brake as needed from NBC index
- See MHS drawing 130E068 for details

See Also

- HB-510 to NBC (Type 3) transition if zoned MDR desired
 - Allows denser packing if product is singulated in, but higher cost

1.1: PRESSURE SWITCH ASSEMBLY

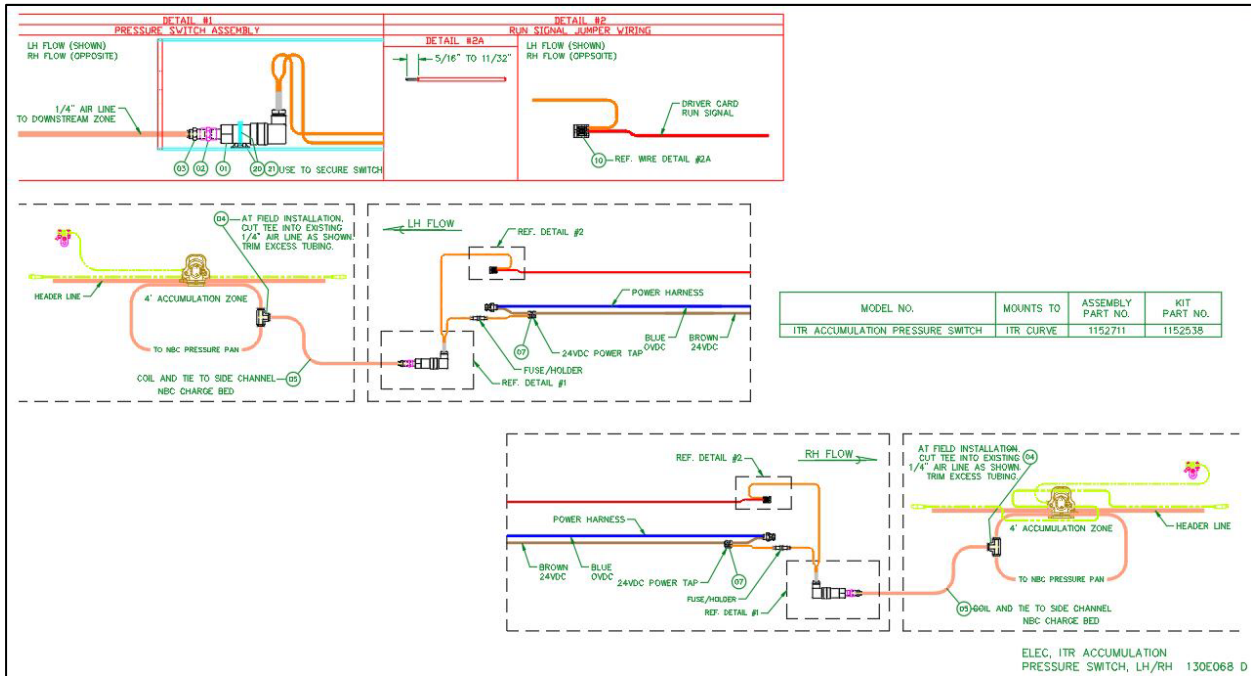

1.2: TYPE 2 CBM-105 DOWNSTREAM SLAVE TO NBC - ACCUMULATION CONTROL

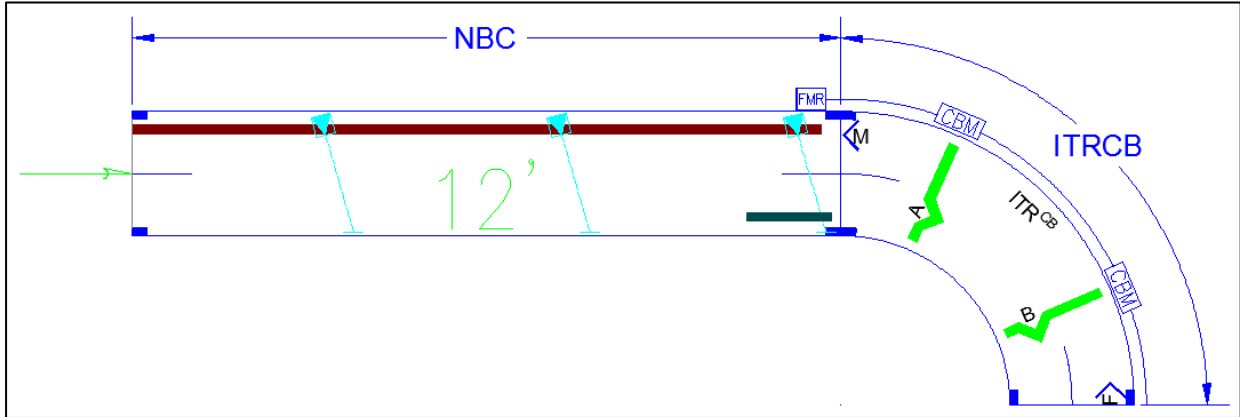

Use When

- NBC is feeding a curve, discharging into transportation or similar (not NBC)
 - If NBC downstream of curve, use Type 1 guidelines

Benefits

- Curve acts as an extension of the upstream NBC zone and runs when a release signal is applied to the function module
- No additional controls wiring beyond function module and product present photoeye, which would already be included
- Eliminates programming to keep the curve clear
- Much higher product throughput than traditional PLC logic and wiring

Requirements

- Release function module at NBC discharge, with PLC release signal connected
- Brake zone in upstream NBC discharge
- Product will remain on curve when release signal is shut off. If curve must be cleared, then a separate run signal is required

How to Order

- Release function module and NBC discharge brake from NBC index
- See MHS drawing 130E037 for field wiring details

See Also

- NBC to HB-510 (Type 4) transition if zoned MDR desired
 - Allows denser packing if product is singulated in, but higher cost

1.3: ACCUMULATION CURVE

Electric IntelliROL Accumulation Curve Left Hand

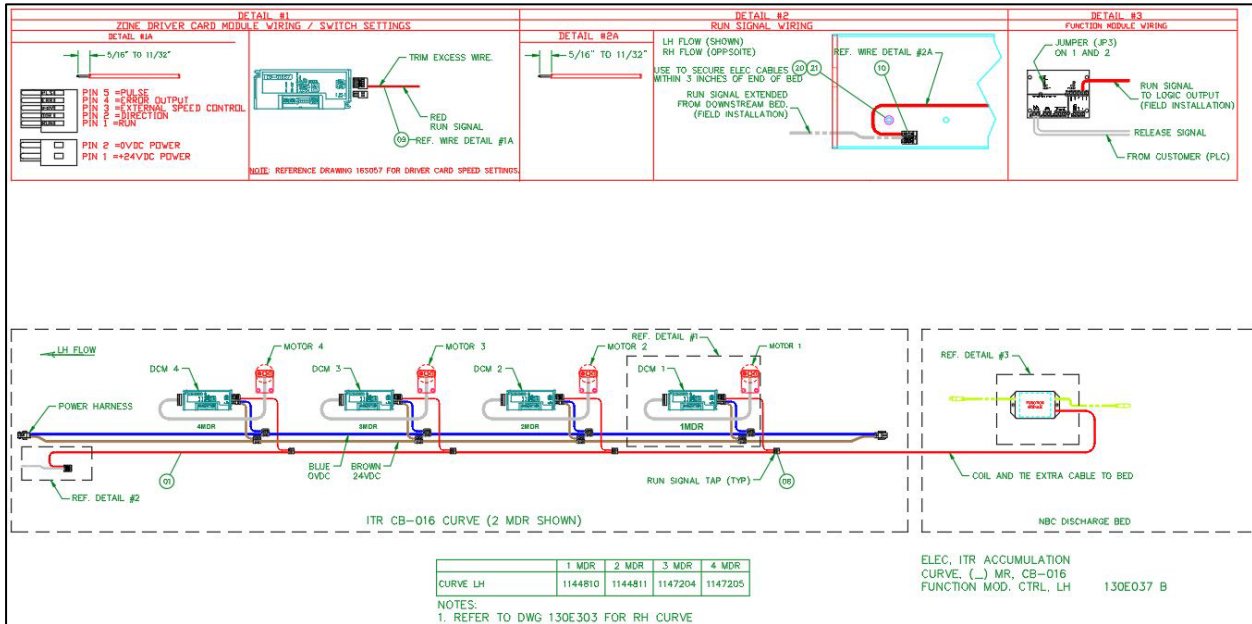

Electric IntelliROL Accumulation Curve Right Hand

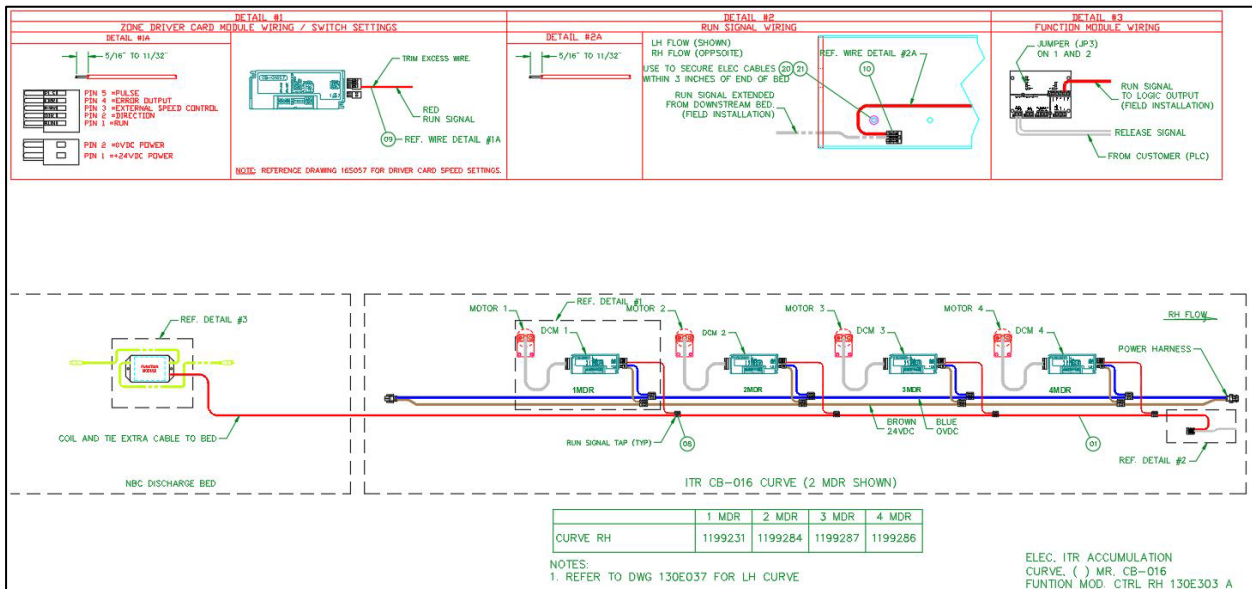

TYPE 3 IS NO LONGER APPLICABLE

Type 3 is no longer applicable.

TYPE 4 NBC TO HB-510 MOTORIZED ROLLER - LOCAL ACCUMULATION CONTROL

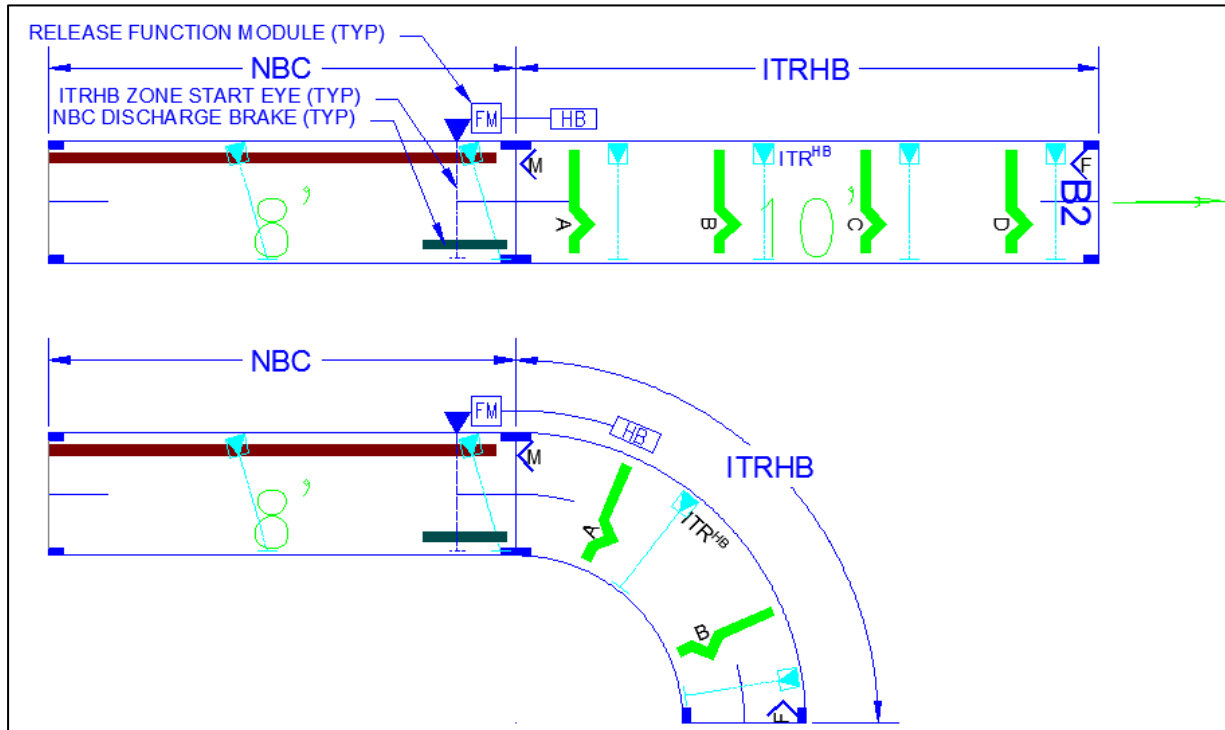

Use When

- NBC is feeding ITR^{HB}

Benefits

- Seamless interface of CRUZcontrol and HB-510 ZPA logic (DENKI, 2014)
- Eliminates PLC wiring for line full, curve stop and upstream conveyor release
- Eliminates programming to keep the curve clear
- All local, low voltage logic and wiring
- Much higher product throughput than traditional PLC logic and wiring

Requirements

- Need power supply for motorized roller to shut off under system stop and E-stop conditions
- MHS function module required on the NBC unit upstream of the curve
- Start eye required at the charge end of the ITR unit.

How to Order

- See MHS drawing 130E102 for wiring details
- Order function module from NBC index and start eye from ITR index

1.4: FIELD WIRING CRUZCONTROL TO ITR TRANSITION

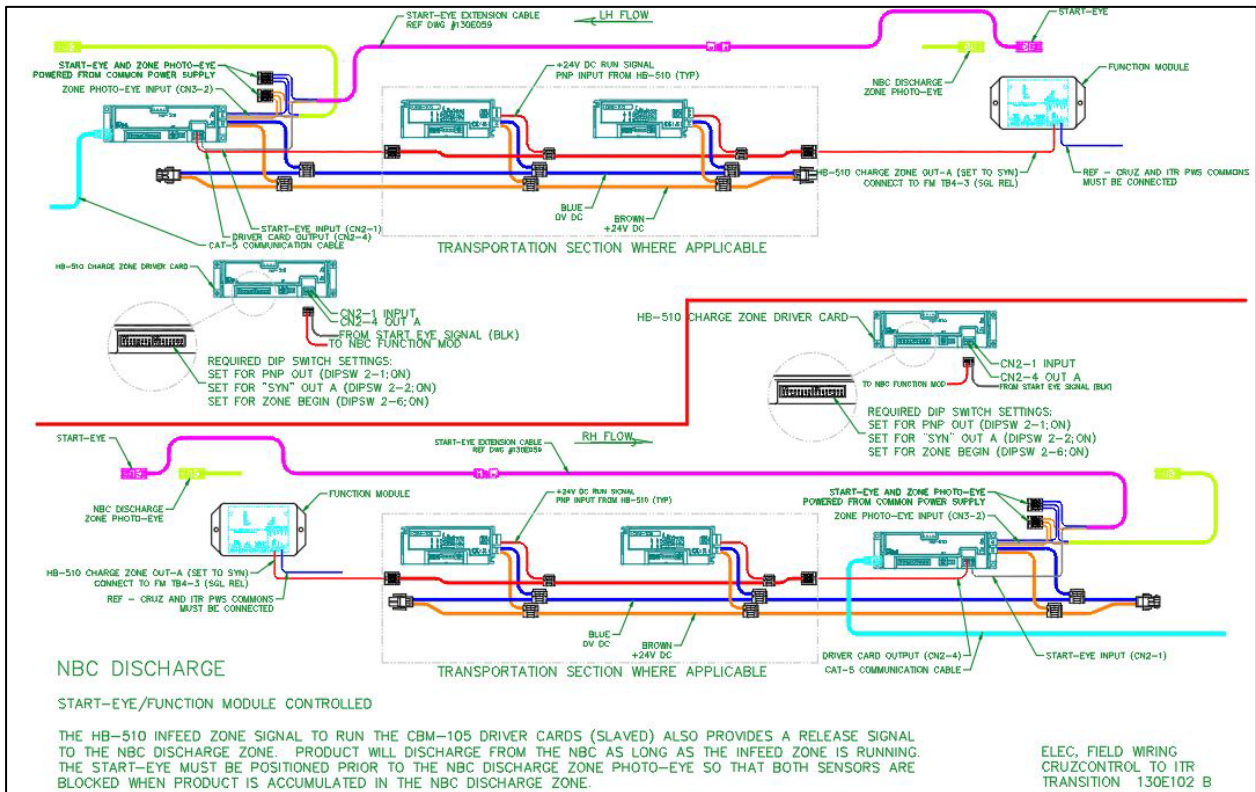

WORKS CITED

ANSI. (2013-2014). *American National Standards Institute*. Abgerufen am 2014 von ANSI Standards Store: <http://www.ansi.org/>

DENKI, I. (2014). *ITOH DENKI*. Abgerufen am 14. 1 2015 von <http://itohdenki.com/>

OSHA. (2014). *Occupational Safety & Health Administration*. Abgerufen am 2014 von OSHA QuickTakes: <https://www.osha.gov/>

MHS CONVEYOR GENERAL INFORMATION

For additional manuals, videos, and other resources visit our website at:

mhs-conveyor.com

ABOUT MHS CONVEYOR

About MHS Conveyor

MHS Conveyor, located in Norton Shores, Michigan, is a leading deliverer of “smart” material handling systems, technologies, products, and services, creating solutions for material flow applications. As a global supplier of conveyor systems and equipment since 1964, MHS Conveyor provides sorters, conveyors, and accessories to satisfy a broad spectrum of accumulation, transportation, and sortation applications.



MHS Conveyor Corp.
1300 E. Mount Garfield Road
Norton Shores MI 49441-6097 USA
231.798.4547
Email : usinfo@mhs-conveyor.com
Web Site : mhs-conveyor.com



Regional sales offices and authorized Business Partners located throughout the United States and Canada. Licensees and Business Partners in Europe, South America, and Southeast Asia.