

Installation, Operation, Maintenance Manual

Supports & Connections

Document Number: 1226673

Revision Date: February 04, 2026

FORTNA • 131 Griffin Way • Mt. Washington, KY 40047
© 2023 2026

FORTNA

Select this link for other
translations

[Fortna-conveyor.com](https://fortna-conveyor.com)

The original manual is English.

Revision Table

REVISION DATE	CHANGE DESCRIPTION	INITIALS
Aug 14, 2023	Initial release with CE standards	MD
No revision change	Remove crawling under conveyor	AB, MM
Feb 04, 2026	Update Manufacturer Address and cover link	MD

Original Instructions

Translated by:N/A

Published by: **FORTNA MI, USA**
 1300 E. Mount Garfield Road
 Norton Shores MI 49441-6097 USA
 USA Tel. + 231.798.4547
usinfo@fortna-conveyor.com

FORTNA Inc.
 1349 W Peachtree St. NW
 Suite 1300
 Atlanta, GA 30309

COPYRIGHT

© FORTNA MI, USA

Preface

Disclaimer

It is the Customer's and the system user's responsibility to ensure that the system is operated only in safe conditions and in accordance with this document and any other documentation or instructions provided by FORTNA or its representatives. THIS DOCUMENT CONTAINS IMPORTANT WARNINGS AND SAFETY REQUIREMENTS. This document must be available to and accessible by any users or anyone with access to the system so that it may be regularly consulted.

ANY PERSON TO USE OR ACCESS THE SYSTEM IN ANY WAY MUST CAREFULLY READ AND UNDERSTAND THIS DOCUMENT. VISITORS OF ANY KIND, AUTHORIZED AND UNAUTHORIZED GUESTS, CHILDREN, ANIMALS AND ANY OTHER PERSON WHO HAS NOT FULLY READ AND UNDERSTOOD THIS DOCUMENT MUST BE KEPT AT A SUITABLE AND SAFE DISTANCE FROM THE SYSTEM. PHYSICAL CONTACT WITH THE SYSTEM MUST BE AVOIDED AT ALL TIMES. SUITABLE WORK CLOTHING AND PROTECTIVE GEAR ARE REQUIRED.

All FORTNA warranties will be voided by any misuse of the system, failure to exercise care, inappropriate behavior, failure to comply with this document or other documentation or instructions supplied by FORTNA or its representatives, or unauthorized modification of the system. Please refer to the applicable FORTNA warranty document for other warranty limitations.

You must contact FORTNA at usinfo@fortna-conveyor.com or (231) 798-4547 immediately with any questions or concerns about this document or the system.

Forward

All rights reserved. No part of this publication may be reproduced, distributed, translated into any language, or transmitted by any electronic or mechanical means, including photocopying, recording or any other storage and retrieval system, for other purposes other than your exclusive personal use, without prior written permission of the Manufacturer. The Manufacturer is by no means liable for the consequences of incorrect operations performed by the user.

Editor's Note

This documentation is expressly addressed to technicians. Therefore, information that can be easily retrieved by reading these texts and analyzing the drawings may not be explained further. The Editor is by no means liable for any information and data provided in this manual: all information included herein has been supplied, controlled, and approved by the Manufacturer during review. The Editor shall by no means be held responsible for the consequences resulting from the user's misuse of the system.

General Remarks

All operating, maintenance instructions and recommendations described in this manual must be respected. For the best results, the Manufacturer recommends cleaning and servicing regularly to keep the partly completed machine as efficient as possible. It is particularly important to train the personnel in charge of this partly completed machine on how to use and service it. They must also comply with the operating procedures and all the safety standards indicated in this manual.

Limitation of Liability

TO THE MAXIMUM EXTENT PERMITTED BY APPLICABLE LAW, FORTNA SHALL NOT BE LIABLE FOR ANY DAMAGES SUFFERED BECAUSE OF USING, MODIFYING, CONTRIBUTING, COPYING, DISTRIBUTING, OR DOWNLOADING THE MATERIALS IN THIS MANUAL.

IN NO EVENT SHALL FORTNA BE LIABLE FOR ANY INDIRECT, EXTRAORDINARY, EXEMPLARY, PUNITIVE, SPECIAL, INCIDENTAL, OR CONSEQUENTIAL DAMAGES (INCLUDING LOSS OF PRODUCTION, REVENUE, PROFITS, USE OR OTHER ECONOMIC ADVANTAGE) HOWEVER ARISING, WHETHER BY BREACH OR IN TORT (INCLUDING NEGLIGENCE), EVEN IF FORTNA HAS BEEN PREVIOUSLY ADVISED OF THE POSSIBILITY OF SUCH DAMAGE. IN NO EVENT SHALL FORTNA BE LIABLE FOR ANY DAMAGES CAUSED BY MISUSE OF THE SYSTEM, FAILURE TO EXERCISE CARE, INAPPROPRIATE BEHAVIOR, FAILURE TO COMPLY WITH THIS DOCUMENT OR OTHER DOCUMENTATION OR INSTRUCTIONS SUPPLIED BY FORTNA OR ITS REPRESENTATIVES, OR UNAUTHORIZED MODIFICATION OF THE SYSTEM.

Customer agrees to sole responsibility for adequate protection and backup of data and equipment used in connection with the product and will not make a claim of any nature against FORTNA for inaccurate output, work delays or lost profits resulting from the use of the materials. Customer agrees to hold harmless from and covenant not to sue FORTNA or its affiliates, successors, or assigns for any claims related to FORTNA relating to the foregoing.

Table of Contents

REVISION TABLE	1
DISCLAIMER	2
FORWARD	2
EDITOR’S NOTE	2
GENERAL REMARKS	2
LIMITATION OF LIABILITY	3
TABLE OF CONTENTS	4
1 CONTACT & IDENTIFICATION	7
1.1 MANUFACTURER CONTACT INFORMATION	7
1.2 MANUFACTURER IDENTIFICATION	8
1.3 IDENTIFICATION OF THE PARTLY - COMPLETED MACHINE	8
1.4 REFERENCE DIRECTIVES.....	9
1.5 WARRANTY.....	10
1.6 FORTNA EQUIPMENT WARRANTY	11
2 GENERAL PRELIMINARY INFORMATION	12
2.1 INTENDED FOR	12
2.2 SUPPLY AND PRESERVATION	13
2.3 MANUFACTURER UPDATES.....	13
2.4 LANGUAGE	13
2.5 QUALIFICATIONS OF AUTHORIZED PERSONNEL	14
2.6 SYMBOLS USED IN THIS MANUAL	16
2.7 SYMBOLS USED THROUGHOUT THE MANUAL.....	17
2.8 GLOSSARY	18
2.9 PERSONAL PROTECTIVE EQUIPMENT	20
3 SAFETY	21
3.1 GENERAL SAFETY WARNINGS	21
3.2 OBLIGATIONS AND PROHIBITIONS.....	23
3.3 NOISE AND EMISSIONS	28
3.4 VIBRATIONS.....	28
3.5 RESIDUAL RISKS	29
4 USER RESPONSIBILITIES	32
4.1 SAFETY PICTOGRAMS	32
4.2 LIST OF PICTOGRAMS.....	33
4.3 SAFETY DEVICES	34
4.4 ERGONOMIC HAZARDS	37
4.5 ANCHORAGE POINTS PERSONAL PROTECTION	37
4.6 FORTNA CONVEYOR ENVIRONMENT STANDARDS	38
4.7 PRECAUTIONS & CLEANING	39
4.8 FORTNA, CONVEYOR CONTROLS SAFETY GUIDELINES	40

5	DESCRIPTION – INTENDED USE	42
5.1	INTENDED USE	42
5.2	STANDARD SPECIFICATION	43
5.3	RESTRICTIONS	43
5.4	REASONABLY FORESEEABLE MISUSE	43
5.5	DEFINITION OF TERMS	44
6	TRANSPORT AND INSTALLATION	46
6.1	GENERAL WARNINGS	46
6.2	DISPOSAL OF PACKAGING	50
7	TRANSPORT AND HANDLING	51
7.1	UNLOADING INSTRUCTIONS	53
7.2	DISPOSAL OF PACKAGING	55
7.3	STAGING OR INSTALLING WITH FORKLIFT	56
7.4	INTELLIROL RECEIVING & SITE PREPARATION	57
7.5	PREPARATION OF SITE	58
7.6	PARTS INVENTORY & IDENTIFICATION	58
	INSTALLATION	60
8	INSTALLATION ARRANGEMENTS	61
8.1	ARRANGEMENTS TO BE MADE BY THE CUSTOMER AND INTEGRATOR	61
	INSTALLATION & APPLICATIONS	64
9	IOM PURPOSE	65
9.1	TOOLS	66
10	SUPPORT ARRANGEMENTS	68
10.1	FLOOR SUPPORTS	68
10.2	ANCHORING	68
10.3	INSTALLING THE CONVEYOR	69
10.4	BASIC INSTALLATION	69
10.5	DIMENSIONAL REFERENCE POINTS	71
10.6	BASIC SQUARENESS	72
10.7	ELEVATIONS	73
10.8	COMPONENT ORIENTATION	73
10.9	ESTABLISHING CONVEYOR FLOW	74
10.10	CURVE SUPPORT POINTS	75
10.11	RF SWAY BRACE	76
10.12	BASIC FLOOR SUPPORT INFORMATION	77
10.13	BASIC CONVEYOR SET UP	78
10.14	GUARDRAIL ASSEMBLY	78
11	SUPPORT & CONNECTION INTRODUCTION	79
11.1	ROLL FORMED (RF) SUPPORT GUIDELINES	79
11.2	RF HEAVY DUTY (HD) SUPPORTS	79

11.3	ROLL FORMED HEAVY DUTY (HD) SUPPORT APPLICATION RULES	79
11.4	RF SUPPORTS FEATURES & BENEFITS	81
11.5	CONVERSION CHART.....	81
12	ROLL FORMED (RF) FLOOR SUPPORTS	82
12.1	STANDARD EQUIPMENT.....	82
13	RF HD FLOOR SUPPORT 18.5 (46.9CM) THRU 30.5 (77.4CM) ELEVATION	84
13.1	RF HD APPLICATION FOR MAXIMUM STRENGTH.....	86
13.2	RF HD FLOOR SUPPORT 146.5 (372.1 CM) THRU 171 (434.3CM) ELEVATIONS.....	87
13.3	RF HD APPLICATION FOR MAXIMUM STRENGTH.....	89
13.4	RF NBS.....	90
13.5	NBS VERTIBELT RF SUPPORTS	91
14	RF CURVE CENTER SUPPORT	92
14.1	7" (17.8CM) THRU 13" (33CM) RF LOW ELEVATION SUPPORT.....	93
14.2	SINGLE LEG 1.5 (3.8CM) THRU 10.5 (26.6CM) LOW ELEVATION SUPPORTS.....	94
15	RF DOUBLE-WIDE SUPPORT.....	95
15.1	HAT CHANNELS - OFFSET.....	96
16	RF TRIPLE-WIDE SUPPORT	97
17	RF MULTI-LEVEL SUPPORT.....	99
18	RF MULTI-LEVEL HEAVY DUTY SUPPORT	101
18.1	RF HD MULTI LEVEL APPLICATION FOR MAXIMUM STRENGTH.....	104
19	C-CHANNEL SPACERS.....	105
20	KNEE BRACES	106
20.1	STANDARD KNEE BRACES	106
20.2	MULTILEVEL KNEE BRACES	108
21	PREVENTIVE MAINTENANCE	110
21.1	INSPECTION SHEET.....	112
22	DECOMMISSIONING AND DISPOSAL	113
22.1	DECOMMISSIONING	113
22.2	DISPOSAL.....	113

1 Contact & Identification

1.1 Manufacturer Contact Information

FORTNA
1300 E. Mount Garfield Road
Norton Shores MI 49441-6097 USA
USA Tel.+ 231.798.4547
Email: usinfo@fortna-conveyor.com

FORTNA Inc.
1349 W Peachtree St. NW
Suite 1300
Atlanta, GA 30309

FORTNA Parts & Service

Attn: Lifecycle Performance Services
Website: fortna-conveyor.com

For additional manuals, videos, and other resources visit our website at:
fortna-conveyor.com

1.2 Manufacturer Identification

MANUFACTURER	NAME & ADDRESS
Address of registered offices	FORTNA MHS Conveyor 1300 E. Mount Garfield Road Norton Shores, MI 49441-6097 USA USA Tel.+ 231.798.4547
Operational Headquarters Address	FORTNA 1349 W Peachtree St NW Suite 1300 Atlanta, GA 30309 USA USA Tel.+ 770.475.0991
Economic Operator	Senior Product Manager, Conveyance Fortna Services CZ s.r.o. Karolinská 661/4 PRAHA 8 - KARLIN 186 00 PRAHA 86 Czech Republic VAT No: CZ17334233

1.3 Identification of the partly - completed machine

IDENTIFICATION OF THE PARTLY - COMPLETED MACHINE	
TYPE	FORTNA - IntelliROL Conveyor
YEAR OF MANUFACTURE	As stated on bed tag. See Sample Label Below
SERIAL NUMBER	Reference CBC on bed tag

Bed Tag Label Sample

An identification label is attached to the outside of one side channel or on a cross member, close to one end of each conveyor bed or partly completed machine.

Refer to [Parts Inventory & Identification](#) in this IOM manual.



1.4 Reference Directives

We, FORTNA, certify that the equipment described above has the following essential health and safety requirements of the Machinery Directive applied and fulfilled. This machinery may not be put into service until the machinery into which it is to be incorporated has been declared in conformity with the provisions of the Directive.

The relevant technical documentation in accordance with Annex VII, Part B of the Machinery **Directive 2006/42/EC** has been compiled. We shall, in response to a reasonable written request by the appropriate national authority, transmit the relevant requested information on the aforementioned partly completed machinery by email.

FORTNA MI, USA, therefore, launches the partly completed machine on the market equipping it and accompanying it with: Declaration of Incorporation

Installation, Operation, Maintenance Manual	Documentation drafted according to point 1.7.4.2 and Annex VI, VII, of Machinery Directive 2006/42/EC.
---	--

It is also noted that the partly completed machine was designed according to the following **Directives**:

2006/42/EC	Machinery Directive
------------	---------------------

The following **harmonized standards** have also been applied:

EN_619;2002+A1;2010	Continuous handling equipment and systems – Safety and EMC requirements for equipment for mechanical handling of unit loads CONSOLIDATED TEXT
---------------------	---

1.5 Warranty

The original warranty is stated in the sales agreement and has priority over that stated in this section if different.

The warranty is subject to the following general conditions:

- Opening of boxes, crates, packages, and installation must be carried out in the presence of the Manufacturer's authorized integrators or technicians.
- The first start-up and positive test of the partly completed machine must be carried out under the supervision of the Manufacturer's authorized integrators and technicians; the sheet of intervention relating to the installation and testing must be drawn up.
- The partly completed machine must be used within the limits specified in the contract and indicated in the technical documentation.
- Maintenance operations shall follow the instruction in this manual, using authentic spare parts by FORTNA and assigning the task to execute these operations to qualified staff.
- The warranty becomes void in the event of:
 - Failure to comply with the safety standards.
 - Removal or tampering with the control and safety devices (guards, photocells, sensors, microswitches, etc.).
 - Improper use of the partly completed machine.
 - Use of the partly completed machine by untrained and/or unauthorized personnel or not according to the competencies of the operators, as indicated in the manual.
 - Changes or repairs made by the user without the manufacturer's written authorization.
 - Non-compliance, partial or total, of the instructions.
 - Energy power supply failures (electric, etc.).
 - Lack in maintenance.
 - Use of non-original spare parts not authorized.
 - Extraordinary events like floods, fires, etc. (unless caused by the machines).

NOTICE



Notice!

- Further details may be found in the commercial contract.
- The conditions of the commercial contract (if different) have priority over those stated in this section.

Failure to follow these instructions can result in property damage or equipment damage.

1.6 FORTNA Equipment Warranty

FORTNA warrants that the material and workmanship entering into its equipment is merchantable and will be furnished in accordance with the specifications stated.

FORTNA agrees to furnish the purchaser without charge any part proved defective within 2 years from date of shipment provided the purchaser gives FORTNA immediate notice in writing and examination proves the claim that such materials or parts were defective when furnished. Other than the above, there are no warranties which extend beyond the description on the face hereof. Consequential damages of any sort are wholly excluded.

The liability of FORTNA will be limited to the replacement cost of any defective part. All freight and installation costs relative to any warranted part will be at the expense of the purchaser. Any liability of FORTNA under the warranties specified above is conditioned upon the equipment being installed, handled, operated, and maintained in accordance with the written instructions provided or approved in writing by FORTNA.

The warranties specified above do not cover, and FORTNA makes no warranties which extend to, damage to the equipment due to deterioration or wear occasioned by chemicals, abrasion, corrosion, or erosion; Purchaser's misapplication, abuse, alteration, operation or maintenance; abnormal conditions of temperature or dirt; or operation of the equipment above rated capacities or in an otherwise improper manner.

THERE ARE NO WARRANTIES, EXPRESSED OR IMPLIED, INCLUDING, BUT NOT LIMITED TO, WARRANTIES OF MERCHANTABILITY OR FITNESS FOR A PARTICULAR PURPOSE, EXTENDING BEYOND THOSE SET FORTH IN THIS STATEMENT OF WARRANTY.

Rev 08/12/2021

2 General Preliminary Information

2.1 Intended For

The manual is intended for the operators in charge of utilizing and managing the partly completed machinery in all its technical aspects. The manual provides information for the correct utilization of the partly completed machine, to maintain its functional and qualitative characteristics unchanged over time. To include safety information and warnings for proper and safe use.

The manual, like the Declaration of Incorporation, is an essential part of the partly completed machine and must always accompany it in every displacement or property transfer. The user must maintain this documentation and make it available for consultation during the entire duration of the partly completed machine.

Failure to follow the instructions and cautions throughout this manual and warning label on the conveyor may result in injury to personnel or damage to the equipment.

Your FORTNA is powered by a motor and can be stopped only by turning off electrical power to the motor. As with all powered machinery, the drive-related components – including sprockets, chains, shafts, universal joints, and pneumatic devices – can be dangerous. We have installed or provided guards to prevent accidental contact with these parts, along with warning labels to identify the hazards.

Symbols / Figures

The pictures and drawings in this manual are purely illustrative and may differ from the actual machine due to technical changes.

Proprietary Rights

All trademarks (™) and intellectual property rights are held by the respective owners.

Copyright

Copyright© FORTNA. All rights reserved worldwide. National copyright law applies to this manual. Nothing in this manual may be duplicated, distributed, translated, passed on, stored in electronic data processing systems, converted to a human or machine language or stored in electronic data processing systems, in any form or in any other way, either electronically, mechanically, magnetically, manually or in any other manner, or disclosed to third parties without obtaining the explicit written permission of FORTNA.

Links To Third-Party Sites

This user manual may contain links to third-party sites, however, FORTNA is not responsible for and cannot control these other sites. FORTNA makes no representations whatsoever about any other website accessed through this user manual. If accessing a non-FORTNA website, even one that may contain a FORTNA logo, it is independent from FORTNA and that FORTNA has no control over the content on that website. In addition, a link to a non-FORTNA website does not mean FORTNA endorses or accepts any responsibility for the content, or the use of such website. Take precautions for viruses, worms, Trojan horses, and other items of a destructive nature.

2.2 Supply and Preservation

The manual is supplied in paper and electronic format. All the additional documentation (plant diagrams, sub-supplier manuals, etc.) is supplied annexed to this manual.

Keep this manual close to the partly completed machine, for easy consultation by the operator.

The manual is an integral part for the purpose of safety, therefore:

- If it is lost or ruined, you should immediately request a copy or scan the QR code on the bed tag or visit the following links.
- New or revised manuals are available at: [Fortna-conveyor.com](https://fortna-conveyor.com)
- Legacy manuals are available at: [Fortna-conveyor/support/legacy/manuals](https://fortna-conveyor.com/support/legacy/manuals).
- It must follow the partly completed machine until it is completed (even if relocation, sale, rental, lease, etc.)

The attached manuals are a part of this document and the same recommendations/prescriptions contained in this manual are applied to them.

NOTICE	
	<p>Notice!</p> <ul style="list-style-type: none"> • This manual is an integral part of the partly completed machine for safety purposes and must, therefore, always accompany it.
Failure to follow these instructions can result in property damage or equipment damage.	

2.3 Manufacturer Updates

If the partly completed machine requires functional modifications or replacements, the Manufacturer is responsible for revising or modifying the manual. The Manufacturer is responsible for delivering the manual update.

The user is also responsible for ensuring that, should this document be modified by the Manufacturer, only the updated manual versions are present in the points of use.

New or revised manuals are available at: [Fortna-conveyor.com](https://fortna-conveyor.com)

Legacy manuals are available at: [Fortna-conveyor/support/legacy/manuals](https://fortna-conveyor.com/support/legacy/manuals).

2.4 Language

The original language for this manual is written in English. All other translations must be done from the original instruction.

The manufacturer shall be responsible for the original information. Translations into different languages cannot be fully verified, inconsistency in translation may be detected, the text in the original language must be referred to or contact the Manufacturer.

2.5 Qualifications of Authorized Personnel

For the purpose of professionalism, the following table establishes what skills and qualifications are required of the personnel in charge of the various duties (starting up, operating, and routine maintenance, etc.):

Operator Qualification

Definitions:

- Operators are authorized to use and operate the partly completed machine for production purposes, for the activities it was constructed and supplied for.
- All operators must be capable of performing all the procedures required for good partly completed machine operations, their personal safety, and the safety of other workers. Have proven experience in the correct use of this type of machine and be trained, informed, and instructed accordingly.
- Must report any irregularity to his/her superior in case of doubt.



Note!

He/she is **NOT** authorized to perform any maintenance activity.

Mechanical Maintenance Engineer

Definitions:

- A qualified Mechanical Maintenance Engineer can carry out preventive/corrective maintenance activities on all the mechanical parts of the partly completed machines subject to maintenance or repairs.
- A qualified Mechanical Maintenance Engineer can access all parts of the partly completed machine for a visual analysis, inspect the equipment status, carry out adjustments, and calibrations.

The Qualified Maintenance Engineer is able to:

- Use the partly completed machine as an operator.
- Intervene on the mechanical elements for adjustments, maintenance, and repairs.
- Read plant diagrams, technical drawings, and spare parts list.
- In exceptional cases, he/she is trained to run the partly completed machine under reduced safety conditions.
- Where necessary, provide the operator with instructions for the proper use of the partly completed machine for production purposes.



Note!

He/she is **NOT** authorized to work on live electrical systems (if installed).

Electrical Maintenance Engineer

Definitions:

- A qualified Electrical Maintenance Engineer can carry out preventive/corrective maintenance activities on all the electrical parts of the partly completed machines subject to maintenance or repairs.
- A qualified Electrical Maintenance Engineer can access all parts of the partly completed machine for a visual analysis, inspect the equipment status, carry out adjustments, and calibrations.

The Qualified Electrical Maintenance Engineer can:

- Use the partly completed machine as an operator.
- Work on adjustments and on the electrical systems for maintenance purposes, repairs, and replacing worn parts.
- Reading wiring diagrams and checking the proper functional cycle.
- Where necessary, provide the operator with instructions for the proper use of the partly- completed machine for production purposes.
- Work while the electrical circuits in the electrical panel, junction boxes, control appliances, etc. live only if the technician is suitably qualified (PEI).



Note!

They **DO NOT** perform software programming of systems such as: PLC (logic or safety) and cannot modify the system passwords.

Manufacturer Technician

Definitions:

- Technician qualified by the Manufacturer and/or by its distributor for complex operations and is aware of the constructive production cycle of the partly completed machine.

Lift Equipment Operator

Definitions:

- A qualified operator of the lifting equipment is aware of the constructive production cycle of the partly completed machine. The lifting operator lifts and moves the partly completed machine per the user requests.
- The qualifications stated fall within a category of people defined “as trained person.”





Trained Personnel

Definitions:

- A person informed, educated, and trained on the work and on any dangers deriving from improper use. Also knows the important safety devices, accident-prevention standards, and safe work conditions.

2.6 Symbols Used in This Manual

Symbols are used throughout the manual to emphasize information of significant importance.



SYMBOL	TYPE	DEFINITION
	ATTENTION	Symbol used to identify important warnings for the safety of the operator and/or partly completed machine.
	FORBIDDEN (MUST NOT)	Symbol used to identify operations that must not be performed or behaviors that must not be adopted as they could cause injury to personnel or damage to the partly completed machine.
	OBLIGATION (MUST DO)	Mandatory action symbol is used to draw attention to a supplementary sign for a specified mandatory action. The mandatory action symbol is used to identify particularly important information inside the manual. The information also regards the safety of personnel involved use of the partly completed machine.
	OBLIGATION TO READ THE INSTRUCTION MANUAL	To use the partly completed machine safely, it is mandatory to read and understand the manual and accompanying documentation in its entirety.
	OBLIGATION TO READ THE TECHNICAL MANUAL	Before service to the partly completed machine safely, it is mandatory to read and understand the manual and accompanying documentation in its entirety.

2.7 Symbols Used Throughout the Manual

Special attention must be made to the following areas of this manual. Listed below are some symbols used throughout the manual to emphasize information of significant importance.

 DANGER	
	Indicates a high level potentially hazardous situation which, if not avoided, will result in death or serious injury.

 WARNING	
	Indicates a medium level potentially hazardous situation that, if not avoided, could result in death or serious injury.

 CAUTION	
	Indicates a low level potentially hazardous situation which, if not avoided, could result in minor or moderate injury. It may also be used to alert against unsafe practices or for the protection of the equipment.

NOTICE	
	Failure to follow these instructions can result in property damage or equipment damage.

2.8 Glossary

Technical terminology or a different meaning from the standard used in the manuals.

Below is the explanation of the different terms and definitions used in this manual:







TERM	DEFINITION
LIFTING ACCESSORIES	Pieces of equipment that are used to attach the load to lifting equipment providing a link between the two. Common examples of lifting accessories are (e.g., rope slings, chains, single or multiple legs), a harness and its components are also considered lifting accessories.
LIFTING CHAINS, ROPES, OR BELTS	Elements designed and built for lifting as integral part of machines for lifting or lifting accessories
PERSONAL PROTECTIVE EQUIPMENT (PPE)	Personal Protective Equipment (PPE) is protective clothing, helmets, goggles, or other garments or equipment designed to protect the wearer's (operator, maintenance engineer, etc.) body from injury or infection.
BREAKDOWN	Element fully unable to perform a required function.
MACHINE	A machine is an apparatus using power to apply force and control movement to perform an action. Assembly, fitted with or intended to be fitted with a drive system, consisting of linked parts or components, at least one of which moves, and which are joined together for a specific application.
PARTLY COMPLETED MACHINE	Partly completed machinery is a term under the Machinery Directive (2006/42/EC) for an assembly of parts which is almost machinery, but which cannot in itself perform a specific application. Partly completed machines are only intended for incorporation or assembly with other machines or with other partly completed machines or devices to form a machine governed by the Machinery Directive.
PROTECTIVE MEASURE	Protective measures are designed or intended to protect something or someone from harm. Measure required to achieve risk reduction, implemented: <ul style="list-style-type: none"> • By design (intrinsically safe project, guards, covers, and additional protective measures, information for use). • By the user (organization: safe operation procedures, surveillance, work permits, availability and use of additional protective equipment, use of personal protective equipment, training).
HAZARD	Potential source of damage that, if not avoided, poses a risk to the safety and health of exposed persons.
EXPOSED PERSON	Any person fully or in part inside a dangerous area.
PREVENTION	The set of provisions or measures required also according to the specific work, the experience, and the technique, to avoid risks or reduce the probability of occurrence.

TERM	DEFINITION
PROTECTION	<p>Defense against what may cause damage. Element placed between those who may suffer damage and what may cause it for hazards that cannot reasonably be eliminated or for risks that cannot be sufficiently reduced during design. The following are distinguished:</p> <ul style="list-style-type: none"> • The active protection that the operators themselves must activate (e.g., emergency stops) and/or wear (PPE). • The passive protection that triggers even without human command.
GUARD	<p>A device, fitted or specifically designed as a barrier and is attached as part of the partly completed machine, to provide protection.</p>
FIXED GUARD	<p>Fixed guards are permanently attached to the machine, don't have any moving parts, and can't be moved while the machine is in use. Permanent part of the machine. Protection held in place (i.e., closed) or permanently (welded) or by means of fixing elements (screws, bolts, etc.) that do not allow removing/ opening without the aid of tools (wrenches, screwdrivers, or Allen screws).</p>
MOVABLE GUARD	<p>A movable guard is mechanically connected to the partly completed machine structure by mechanical means (e.g., hinges, slides, or guides) and is attached to the machine frame or an adjacent fixed element. It can be opened without a use of a tool.</p>
UNEXPECTED START-UP	<p>Unintended start-up. Any start-up which, because of its unexpected nature, generates a risk to persons.</p>
RISK	<p>Combination of the probability of occurrence of damage and the severity of that damage.</p>
RESIDUAL RISK	<p>Portion of risk remains after applying protective and preventive measures.</p>
INTENDED USE	<p>Use of a machine in accordance with the information provided in the instructions for use.</p>
REASONABLY FORESEE- ABLE MISUSE	<p>Use of a machine or systems in a way not intended by designer, but which can result from foreseeable human behavior.</p>

2.9 Personal Protective Equipment

When operating near the partly completed machine for assembly and maintenance and/or adjustment operations strictly respect the main accident-prevention rules. For this purpose, it will be important to use the personal protective equipment (PPE) required for each individual operation.

Below is the full list of personal protective equipment (PPE) that may be required for the different procedures:

SYMBOL	DESCRIPTION
	Obligation to use protective or insulating gloves. Indicates a requirement for personnel to use protective or insulating gloves.
	Obligation to wear eye protection. Indicates a requirement for personnel to use approved safety eye protection.
	Obligation to use safety shoes. Indicates a requirement for personnel to wear work-safety footwear.
	Obligation to use noise protection devices. Indicates a requirement for personnel to use headphones or earplugs to protect hearing.
	Obligation to use protective clothing.
	Obligation to use the safety harness Must use safety harness for work at elevated heights.
	Obligation to use a protective helmet. Indicates a requirement for personnel to wear head protection.

The clothing worn by individuals running the machine or performing maintenance on the partly completed machine must comply with the essential safety requirements defined by regulations in force in the country where it is installed/used.

3 Safety



3.1 General Safety Warnings



The purpose of this chapter is to inform the personnel of any possible dangers and risks as well as of general and specific recommendations to eliminate or minimize said risks.

This chapter has information and instructions regarding:

- Dangerous situations that can arise during use and maintenance of the partly completed machine.
- Guards and safety devices adopted and their correct use.
- Residual risks and conduct to adopt (general and specific recommendations to avoid or reduce them).

This Installation Operation Maintenance (IOM) manual briefly summarizes these instructions in the sections where the described situations occur.

 DANGER	
	<p>Protective Devices</p> <ul style="list-style-type: none"> • It is forbidden to use the partly completed machine or completed machine with no guards or protection devices, or with guards or protection devices deactivated. Ignoring the above can cause serious damage and/or accidents.
<p>Indicates a high level potentially hazardous situation which, if not avoided, will result in death or serious injury.</p>	

 WARNING	
	<p>Operation Manual Illustrations</p> <ul style="list-style-type: none"> • Some illustrations representing the partly completed machine are shown without the protection guards or with the guards removed to show specific details. This is necessary for the sake of clarity in the description. • Some drawings represented in this operation manual are for visual reference only and as such not all drawings contain completed drawing information such as dimensions, notes, conveyor labels, or safety symbols.
<p>Indicates a medium level potentially hazardous situation that, if not avoided, could result in death or serious injury.</p>	

CAUTION



Electrical Connection





- To incorporate the partly completed machine within the destination line, it is necessary to provide the external electrical connection for the activation of the safety functions of the partly completed machine by the control logic of the line itself.









Indicates a low level potentially hazardous situation which, if not avoided, could result in minor or moderate injury. It may also be used to alert against unsafe practices or for the protection of the equipment.

3.2 Obligations and Prohibitions

3.2.1 Obligations

Listed are obligations that are mandatory and **Must Do!**









	<h2>THE WORKERS MUST DO!</h2>
   	<ul style="list-style-type: none"> • Must Do, carry out maintenance operations with the partly completed machine switched off. Do not lubricate moving parts. • Must Do, parts over 18kg should be lifted by two people. • MUST DO, step ladder must be used when performing maintenance or cleaning on items that cannot be reached from floor level. • Must Do, tie up long hair or long beards, avoid wearing scarves or other clothes that may get trapped in the moving parts of the partly completed machine. All loose clothing, long hair, long beards, and jewelry must be kept away from moving equipment. • Must Do, remove jewelry such as bracelets, rings or necklaces that may get trapped in moving parts, thus creating a risk for the operator. • Must Do, always perform interventions on the electrical system components in the absence of voltage (main switch off). • Must Do, make sure that no-one is standing in the danger zones during the start-up and operation of the partly completed machine. • Must Do, use extreme caution to avoid injury or property damage during use of the partly completed machine. • Must Do, know the location and operation of the stopping device. • Must Do, comply with instructions and provisions given by the employer, managers, or supervisors, to ensure personal and collective safety. • Must Do, make proper use of equipment, tools, substances, and dangerous products, means of transport and other working machinery, as well as safety devices. • Must Do, make correct use of all personal protective equipment they have been provided with • Must Do, after maintenance, must REPLACE guards immediately. • Must Do, keep ALL warning labels clean and clear of any obstructions. • Must Do, must be trained to never remove, deface, or paint over symbols or labels of any kind. Any damaged label will be replaced by FORTNA at no cost by contacting Lifetime Services. • Must Do, it is very important to instruct personnel in proper conveyor use, including the location and function of all controls. • Must Do, special emphasis must be given to emergency stop procedures. • Must Do, it is important to establish work procedures and access areas, which do not require any part of a person to be under the conveyor.

	<h2>THE WORKERS MUST DO!</h2>
<div style="display: flex; flex-direction: column; align-items: center; gap: 10px;">         </div>	<ul style="list-style-type: none"> • Must Do, after the power source is turned off and locked out trained maintenance technician are to remove blockage or jams from the partly completed machine. • Must Do, maintain enough clearance on each side of all conveyor units for safe adjustment and maintenance of all components • Must Do, provide crossovers or gates at sufficient intervals where needed to eliminate the temptation for personnel to climb over or under any conveyor. • Must Do, use the partly completed machine within the approved environmental conditions. • Must Do, BEFORE performing maintenance on the conveyor, make sure the start-up controls are locked out and cannot be turned on by any person other than the one performing the maintenance. • Must Do, if more than one crewmember is working on the conveyor, EACH CREW MEMBER MUST HAVE A LOCK ON THE POWER LOCKOUT. • Must Do, maintain enough clearance on each side of all conveyor units for safe adjustment and maintenance of all components. • Must Do, all pneumatic devices must be de-energized, and air removed to prevent accidental cycling of the device while performing general maintenance. • Must Do, make sure all personnel are clear of all conveyor equipment before restarting the system. • Must Do, watch for nip points or pinch points. A pinch point hazard is a common class of mechanical hazard where injury or damage may be done by one or more objects moving towards each other, crushing, or shearing whatever comes between them. A nip point is a type of pinch point involving rotating objects, such as gears and pulleys. • Must Do, BEFORE restarting a conveyor, which has been stopped because of an emergency, an inspection of the conveyor must be made, and the cause of the stoppage determined. The starting device must be locked out before any attempt is made to correct the cause of stoppage. • Must Do, make correct use of all personal protective equipment that they have been provided with. • Must Do, know the workplace and traffic routes, and all required protections/guarding of nearby hazardous equipment. • Must Do, know IntelliROL equipment starts and stops without warning and can cause severe injury. • Must Do, employees that come in contact with the equipment must be warned of the dangers of an unexpected start. • Must Do, hands can be crushed between products or products and channels. • Must Do, BEFORE servicing or performing any work in the motor control panel, disconnect and padlock out air and the main incoming service. If ONLY the panel disconnect is off, the incoming side will still be hot.

	THE WORKERS MUST DO!
	<ul style="list-style-type: none"> • Must Do, all safety rules must be observed when working with, on or at the conveyor system in whatever way. This includes reading all installation, operation, maintenance, or technical manuals.
<p>Indicates a medium level potentially hazardous situation that, if not avoided, could result in death or serious injury.</p> <p>Mandatory action symbol is used to draw attention to a supplementary sign for a specified mandatory action.</p> <p>The mandatory action symbol is used to identify particularly important information inside the manual. The information also regards the safety of personnel involved use of the partly completed machine.</p>	

3.2.2 Prohibitions

Listed are prohibitions and are mandatory **Must Not Do** to avoid the hazard!

	The Worker MUST NOT!
      	<ul style="list-style-type: none"> • Must Not, use the partly completed machine improperly, i.e., for uses other than those indicated in the “Intended use” paragraph. • Must Not, remove or modify the safety or signaling devices without authorization. • Must Not, remove, deface, or paint over symbols or labels of any kind. Any damaged label will be replaced by FORTNA at no cost by contacting Lifetime Services. • Must Not, convey hazardous materials. • MUST Not, remove or install heavy parts whilst anyone is working on the floor level below the parts to be moved. This will help stop accidental falling of heavy parts onto people. • Must Not, carry out, upon their own initiative, operations or maneuvers they are not in charge of and that can jeopardize their own safety and that of other workers. • Must Not, wear bracelets, rings or necklaces that may get trapped in moving parts, thus creating a risk for the operator. • Must Not, replace or modify the speed of partly completed machine components without being authorized by a manager. • Must Not, modify the partly completed machine operating cycle. • Must Not, modify the connections to exclude the internal safety devices. • Must Not, use the partly completed machine if not properly incorporated within the final line, according to current regulations. • Must Not, use the partly completed machine or its components as point of support even if not operational (risk of falls and/or risk of damaging the components themselves). • Must Not, use the partly completed machine outside of the admitted environmental conditions. • Must Not, touch Motor rollers as they can become hot! • Must Not, touch any type of Motor as the motor may be hot! • Must Not, clear jams while the equipment is running. • Must Not, do not pull on equipment parts, such as belts, pulleys, or shafts, to assist slow starting equipment.
<p>Indicates a high level potentially hazardous situation which, if not avoided, will result in death or serious injury.</p> <p>Symbol used to identify operations that must not be performed or behaviors that must not be adopted as they could cause injury to personnel or damage to the partly completed machine.</p>	

NOTICE



Notice!

- FORTNA is not liable for damage to property or people if it has been determined that the partly completed machine has been used in one of the non-admitted environments.

Failure to follow these instructions can result in property damage or equipment damage.

3.3 Noise and Emissions

Noise levels have been measured in accordance with the requirements of the relevant regulations in force. During the operating cycles, the levels of exposure to noise for personnel **do not exceed 80 dBA**.



The actual noise levels of the incorporated partly completed machine during operation on site and in a manufacturing process, differ from those detected, as the noise is influenced by factors such as:

- Type and features of the site.
- Other adjacent machines in operation.

NOTICE	
	<p>Notice!</p> <ul style="list-style-type: none"> • It is the precise responsibility of the end user/customer to apply the relevant preventive and protective measures in compliance with the law in the country of installation and use of the partly completed machine. • Always wear recommended personal protective equipment.
Failure to follow these instructions can result in property damage or equipment damage.	

3.4 Vibrations

The vibrations produced by the partly completed machine, depending on its method of operation, do not pose a risk to the health of the operators.

 CAUTION	
	<p>Caution!</p> <ul style="list-style-type: none"> • An excessive vibration can only be caused by a mechanical fault that must be immediately reported and eliminated, to avoid jeopardizing the safety of the partly completed machine and operators.
<p>Indicates a low level potentially hazardous situation which, if not avoided, could result in minor or moderate injury. It may also be used to alert against unsafe practices or for the protection of the equipment.</p>	

NOTICE	
	<p>Notice!</p> <p>FORTNA partially completed machine do not produce non-ionizing radiation which may cause harm to persons.</p>
Failure to follow these instructions can result in property damage or equipment damage.	

3.5 Residual Risks





The partly completed machine was designed to guarantee the essential safety requirements for the operator.







Safety has been incorporated, as much as possible, into the design and construction of the partly completed machine; however, there are risks from which the operators must be protected, especially during:

- Transport and incorporation or moving parts.
- Normal operation.
- Adjustments and fine tuning.
- Maintenance.
- Disassembly and dismantling.

For each residual risk, there is a description of the risk and of the zone or part of the partly completed machine subject to that residual risk, unless the risk is valid for the entire partly completed machine.

Procedural information as to how to avoid the risk and on the correct use of the personal protective equipment intended and prescribed by the Manufacturer is also supplied.

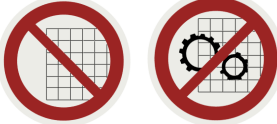

RESIDUAL RISK	DESCRIPTION	PROCEDURAL INFORMATION
 <p>HAND ENTANGLEMENT. BELT DRIVE WITH TEETH</p>	Limbs can get stuck during maintenance when the protections have been removed for inspection or repair.	Follow the procedures described and observe the safety instructions.
		Never turn on the partly completed machine without the safety protections installed.
 <p>HAND CRUSHED PINCH POINT OR ABOVE</p>		Turn the power off when working on the partly- completed machine.
		Lock the system to prevent it from being turned on inadvertently!
 <p>ELECTROCUTION HAZARD</p>	Contact with a power source during maintenance.	Always turn the power off when working on the partly completed machine.
		Do not attempt to perform maintenance without having first de-energized the system.
 <p>INJURIES TO THE LIMBS CAUSED BY CONTACT WITH MOVING PARTS</p>	Contact with moving parts during operation can cause minor or serious injuries.	Always keep sufficient distance from the partly complete machine.
		Never insert your hands into the partly completed machine or a complete machine when it is running or not running. Do not insert your hands on or in between materials being conveyed.

RESIDUAL RISK	DESCRIPTION	PROCEDURAL INFORMATION
 <p>AUTOMATIC START</p>	<p>Know IntelliROL equipment starts and stops without warning and can cause severe injury.</p>	<p>Never insert your hands into the partly completed machine or a complete machine when it is running or not running.</p> <p>Do not insert your hands on or in between materials on the being conveyed.</p>
 <p>FALL HAZARD STANDING OR WALKING ON CAONVYOR</p>	<p>Risk of falling when standing or walking on the conveyor.</p>	<p>Never stand, walk on the conveyor.</p>
 <p>DO NOT REACH MOVING PARTS UNDERNEATH</p>	<p>Contact with moving parts during operation can cause minor or serious injuries.</p>	<p>Never insert your hands into the partly completed machine or a complete machine when it is running or not running.</p>
 <p>RISK OF INJURIES TO THE LIMBS CAUSED BY CONTACT WITH MOVING PARTS</p>	<p>Risk of falling due to walking, sitting, standing, or climbing on the conveyors belt, rollers, or any part of the conveyor systems, even when it is not moving.</p>	<p>Do not walk, stand, sit, or climb on the partly or completed machine when it is stationary or running.</p>
	<p>Ignoring the guards missing can cause serious damage and/or accidents.</p>	<p>It is forbidden to use the partly completed machine or completed machines with no guards and protection devices.</p>
	<p>Must read all manuals.</p>	<p>Manuals must stay with a partly completed machine or completed machine. All safety rules must be observed when working with, on or at the conveyor system in whatever way. This includes reading all Installation, Operation, Maintenance manuals.</p> <p>Before service to use the partly completed machine safely, it is mandatory to read and understand the manual and accompanying documentation in its entirety.</p>

4 User Responsibilities



It is the responsibility of the user to:

- Analyze the risks that might occur during handling and installation at his/her premises (the analysis done on the handling of the partly completed machine only took into consideration the characteristics of the same).
- Mark out the path of forklift trucks and/or laser guided vehicles, with appropriate floor signs.
- Awareness-raising and training of the personnel in charge of performing operations on workstations as well as partly- completed machine operators.
- Apply the visual safety signs in the work environment after having evaluated the risks inside the areas of transit or control.
- The integrator or end user/customer supply workstation layouts.

 CAUTION	
	The end user of the line must, during the incorporation, reduce the risks in the different zones of the partly- completed machine, according to the general risk analysis of the line itself.
Indicates a low level potentially hazardous situation which, if not avoided, could result in minor or moderate injury. It may also be used to alert against unsafe practices or for the protection of the equipment.	















4.1 Safety Pictograms

The partly completed machine is equipped with a series of pictograms, which serve the purpose of warning the operator of any residual risks.

	<p>PROHIBITION MUST NOT!</p> <ul style="list-style-type: none"> • IT IS STRICTLY FORBIDDEN to remove the pictograms installed on the partly completed machine. • FORTNA will not be held liable for the safety of the partly completed machine should this prohibition be disregarded.
	<p>MANDATORY ACTION MUST DO!</p> <ul style="list-style-type: none"> • General mandatory action sign indicates an action to take to avoid the hazard. • FORTNA will not be held liable for the safety of the partly completed machine should this prohibition be disregarded.
	<p>CAUTION!</p> <ul style="list-style-type: none"> • Possible risk of damage to the machine if the incorrect procedure is used.

4.2 List of Pictograms

The following table lists the pictograms present on the partly completed machine but are not limited to only these pictograms.

PICTOGRAM AND DESCRIPTION		
 <p>AUTOMATIC START UP</p>	 <p>HAND ENTANGLEMENT. BELT DRIVE WITH TEETH</p>	 <p>HAND CRUSH FROM NIP OR PINCH POINT</p>
 <p>HAND ENTANGLEMENT IN ROLLERS</p>	 <p>ELECTRICAL HAZARD</p>	 <p>HAND ENTANGLEMENT</p>
 <p>FALL HAZARD FROM CONVEYOR</p>	 <p>DO NOT STEP, STAND OR SIT</p>	
 <p>DO NOT REACH MOVING PARTS UNDERNEATH</p>	 <p>DO NOT OPERATE WITHOUT GUARDS MOVING PARTS UNDERNEATH</p>	 <p>DO NOT OPERATE WITHOUT GUARDS</p>
 <p>ENGLISH WRENCH REQUIRED</p>	 <p>LOCK OUT TAG OUT PNEUMATIC</p>	 <p>LOCK OUT TAG OUT ELECTRICAL</p>

4.3 Safety Devices

To ensure maximum operator safety, the partly completed machine has been equipped with safety devices that minimize the risks for the operator. Safety devices are supplied by the integrators such as:

- Control systems
- Emergency stop systems
- Netting
- Fences

NOTICE







- Contact your customer/ integrator for specific safety information installed on your partly completed machine.
- The integrator's (or end user's) responsibility is to ensure appropriate safety conditions.
- FORTNA will not be held liable for the safety of the partly completed machine or people should this prohibition be disregarded.

Failure to follow these instructions can result in property damage or equipment damage.

4.3.1 Safety for Fences, Nets, Covers and Guards

Where applicable safety fences, netting, covers and guards must be applied.

POS	ELEMENT	DESCRIPTION
1	Safety Fence	 <p>Safety fencing may be necessary depending on risk assessments and evaluations done by others.</p>
		<p>FORTNA does not provide or sell fencing.</p>
2	Safety Net	 <p>It is advised for the customer of FORTNA to provide safety netting or other fall protection to protect anyone underneath the conveyor from falling load.</p> <p>FORTNA has added extra holes to the ceiling hanger crossmembers, as a service to our customers, to help attach safety netting to the bottom of an overhead conveyor.</p>
		<p>FORTNA does not provide or sell safety netting.</p>

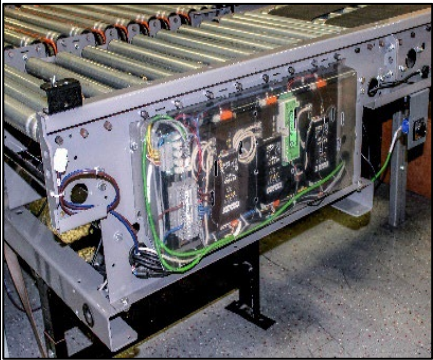
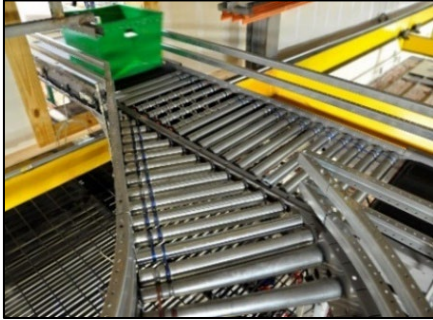
POS	ELEMENT	DESCRIPTION	
<p>3</p>	<p>Safety Covers & Guards</p>	 <p>Shrouds cover electrical components and wire's.</p>	 <p>Plexi glass cover provides safety while providing a visual perspective. Plexi glass covers are supplied on certain electrical panels or other mechanical actions such as transfer take-ups.</p>
		 <p>Guard rails help guide carton or totes and protect product from falling off the conveyor.</p>	

4.4 Ergonomic Hazards



Access to parts of the partly completed machine located in high elevation or over machinery shall be provided with proper means of protection against falls which may include but are limited to, guard rails for stairways, stationary stepladders, platforms, or safety cages for ladders.

Improper access or poor location of controls could cause poor posture, issues that may lead to discomfort, fatigue, musculoskeletal disorder, stress, or inaccessibility for cleaning, maintenance, and similar hazards.

Assuring appropriate safe access to partly completed machine, safety controls, and equipment conditions is the integrator's (or end user's) responsibility.

4.5 Anchorage Points Personal Protection

Anchorage points for personal protective equipment against falls from height shall also be provided.

 WARNING	
	<p>Warning!</p> <ul style="list-style-type: none"> Maintenance done above 1.82m must be tied off with fall protection safety harness.
<p>Indicates a medium level potentially hazardous situation that, if not avoided, could result in death or serious injury.</p>	

NOTICE	
	<p>Notice!</p> <ul style="list-style-type: none"> The integrator's (or end user's) responsibility is to ensure appropriate safety conditions. FORTNA will not be held liable for the safety of the partly completed machine or people should this prohibition be disregarded.
<p>Failure to follow these instructions can result in property damage or equipment damage.</p>	

4.6 FORTNA Conveyor Environment Standards

FORTNA Environment Policy

FORTNA equipment is designed to be installed in a clean, dry warehouse environment. Exposure to extreme humidity, direct sunlight, blowing dirt or rain can permanently damage some components of FORTNA. In particular, the curing agents in concrete are known to attack and degrade the urethane conveyor equipment.

When installing conveyor on a new construction site, be sure that the concrete is properly cured before setting conveyor on it. In addition, if conveyors are stored in proximity of curing concrete, proper ventilation must be used to direct the curing agent fumes away from the conveyor.

Failure to comply with these guidelines will void the FORTNA warranty on any failed components that result from these environmental issues.

Pressurized Air Quality:

No FORTNA Manufacturer components require lubricated air. If the shop air is lubricated there must be a coalescing filter plus a regular filter of 5 micron installed in the line prior to the air reaching all FORTNA equipment.

In high humidity or low temperature situations an air dryer must be used.

Installation Environment:

All FORTNA technologies are designed to function in “normal” industrial environments. Chemical vapors, lubrication, excessive dust, high or low heat and moisture may affect their operation and void the equipment warranty. Some paint fumes, fresh concrete and other concentrations of airborne fumes have been known to adversely affect the life of many conveyor components and will void the equipment warranty.

4.7 Precautions & Cleaning

Precautions

ULTRAVIOLET RAYS of sunlight will weaken polyurethane belts.

OILY OR WET CONDITIONS impair frictional drive characteristics between polyurethane belts and roller grooves.

CORROSIVE SUBSTANCES such as concrete curing agents will adversely affect various components, voiding the warranty.

Temperature range (ambient):

+35° to +100°F. For applications that exceed this temperature range, please consult Applications Engineering.

Grounding:

Equipment should be properly grounded before operation.

Cleaning O-Rings

The manufacturer suggested procedure for cleaning O-rings is to use a cloth with de-natured alcohol and not to clean them unless they are greasy, or you are experiencing issues such as slipping. This cleaning product would also work for cleaning rollers.

Note:



Do **NOT** immerse the O-rings or any component in a container of this cleaning product.

Washdown Applications: No FORTNA manufactured conveyor equipment is designed or capable of being washed down. Even extremely high humidity may affect the ability of the equipment to convey loads as desired.

CAUTION WHEN CLEANING PRODUCTS:

	<ul style="list-style-type: none"> Cleaning products are not provided by FORTNA, and as such, users are instructed to follow the local regulations and the manufacturer safety instructions for use and to follow the PPE (Personal Protective Equipment) guidelines. Also, dispose of rags and other used media in accordance with the manufacturers recommendation and your company policy.
	<ul style="list-style-type: none"> The end user is to provide the user with the Safety Data Sheet (SDS).
	<ul style="list-style-type: none"> Ensuring a good and safe interior environment is the integrator's (or end user's) responsibility.
	<ul style="list-style-type: none"> Must Not! Never clean any parts of the partly completed machine or completed machine while the conveyor is running. The equipment should not be started again until it is certain that it is all clear and safe to do.

4.8 FORTNA, Conveyor Controls Safety Guidelines

The following basic conveyor control safety guidelines are recommended by FORTNA even though Business Partner may or may not purchase conveyor controls from FORTNA. The items listed deal with applications of controls equipment. The actual installation of the equipment must always follow the National Electric Code and all other local codes.

Start-up Warning Horn

Ideally, all conveyors should be within sight of the conveyor start pushbutton. This allows the operator to verify that no one is touching the conveyor or would be in danger if the conveyor were to start up.

If it is not possible to see the entire conveyor being started from the start pushbutton location, then some form of audible warning device is required. It could be a horn, buzzer, bell, or anything unique to that conveyor for that location. It should be loud enough to be heard at any point on the conveyor system. It should sound for approximately five seconds after the start pushbutton is pushed, prior to the actual running of conveyor. Any auxiliary equipment such as vertical lifts, turntables, etc., should also be included in the warning circuitry. Conveyors that stop and restart under automatic control could also require a horn warning prior to restarting. If it is not easy to distinguish the difference between a fully stopped conveyor system and a momentarily stopped conveyor section, then it is advisable to add a warning horn. All conveyor sections that stop and restart automatically should be marked with appropriate signs or labels.

Start Pushbuttons

Start pushbuttons should be the flush type or guarded such that inadvertently leaning against them will not actuate the conveyor. They should be provided with a legend plate clearly defining which conveyors will be started.

Stop Pushbuttons

Stop pushbuttons should be the extended type such that any contact with it is sufficient to stop the conveyor. They would also be provided with a legend plate clearly defining which conveyors will be stopped.

Operator Controls

Additional operator controls should be designed into the system with the same guidelines that go into start and stop pushbuttons, depending upon their function. Devices which are repeated on multiple control stations, such as emergency stops, should be located at the same relative location on each station (such as lower right corner).

Emergency Stops

All locations where an operator must work directly at the conveyor may be subject to local safety codes requiring e-stops. It is the responsibility of the integrator to check with state and local authorities on the need and application of e-stops.

Emergency stops can be of the pushbutton or cable operated switch type. The pushbutton type should be a red, mushroom head maintained pushbutton which requires resetting after it is actuated. Cable operated switches should trip by pulling the cable and require resetting at the switch.

Actuating an emergency stop must drop-out the start circuit, requiring restarting the system using the start pushbuttons provided.

An emergency stop should normally stop all conveyors in the system. Very large systems may involve dividing a system into zones of control based on proximity of personnel, safety hazards, walls obstacles, etc.

Controls Logic

Solid state controls logic devices, such as programmable controllers are used extensively for conveyor control. They are very reliable, but a hardware failure or software bug would cause an output to function erratically. For this reason, start circuits, warning horn circuits, and emergency stops should usually be configured using conventional relay logic.

Safety Switches

All conveyor control cabinets and motors should be provided with safety (or disconnect) switches. These switches must have provisions for padlocking. As required for maintenance, equipment should be locked in the off position.

Special Devices

Special devices and equipment such as vertical lifts, turntables, high speed conveyors, etc., all have unique design and safety requirements. These should be looked at in each case to determine what the requirements might be.04/06/2023



5 Description – Intended Use

5.1 Intended Use

Roll Form (RF) supports applications that are defined in this manual and are designed to hold the FORTNA modules.

The application for anchoring, connecting, or ceiling hanging of the conveyor modules are illustrated in this Support & Connection manual.

Restriction

 DANGER	
	<p>Danger!</p> <ul style="list-style-type: none"> • If RF Heavy Duty supports are used for “Seismic” conditions or ratings it shall be noted: • Compliance assurance per all application codes and requirements is by others. • FORTNA can provide drawings as needed to Systems Integrator for proper evaluation and approval by their Structural Engineer. • Maximum support crossmember center distance not to exceed 54” (1.37m). All hardware that has been loosened during installation must be retightened to 55 ft-lb. (75 Nm) Failure to do so could cause structural failure.
<p>Indicates a high level potentially hazardous situation which, if not avoided, will result in death or serious injury.</p>	

The partly completed machine has been created to:

- Satisfy the specific demands mentioned in the sales agreement.
- Be used according to instructions and limitations for use set out in this manual.

The partly completed machine is designed and built to work safely if:

- It is used within the limits stated in the contract and in this manual.
- The usage manual procedures are followed.
- Ordinary maintenance operations are performed as indicated.
- Extraordinary maintenance is performed promptly, in case of need.
- Safety devices are not removed and/or modified.

5.2 Standard Specification

Specifications are defined in the product chapters.

5.3 Restrictions

Restrictions are defined for heavy duty RF Supports chapters.

5.4 Reasonably Foreseeable Misuse

Reasonably foreseeable misuse is listed below:

- Conveying of people.
- Climbing, standing, sitting, or walking on top of the conveyor.
- Placing hands between rollers.
- Using the partly completed machine without having correctly incorporated it in the destination line.
- Using the partly completed machine as a support.
- Using the partly completed machine to achieve greater production values than the required limits.
- Using partly completed machine to convey hazardous materials.
- Using the partly completed machine differently than in the “intended use” paragraph.
- Not reading the Installation, Operation, Maintenance manual.

Any use of the partly completed machine that differs from the intended use must be authorized beforehand in writing by the Manufacturer. Without this written authorization, the use must be considered “**improper use;**” therefore, the Manufacturer declines any liability for eventual damage to persons or property and deems any kind of warranty on the partly completed machine void.

NOTICE	
	<p>Important!</p> <ul style="list-style-type: none"> • Incorrect use of the partly completed machine or completed machine excludes any liability by the Manufacturer.
<p>Failure to follow these instructions can result in property damage or equipment damage.</p>	

5.5 Definition of Terms

Conveyor terminology or different meanings pertaining to conveyor applications, parts, types, and functions that may be used in the manual.

Below is the explanation of the different terms and definitions used in this manual:

TERM	DEFINITION
Bed	The part of the conveyor the load or carrying medium rests or slides while being conveyed.
Between Frames (BF)	Inside width dimension, the abbreviation "BF" (between frames) is used.
Conveyor Width	The dimension outside to outside of frame rails. For the inside dimension, the abbreviation "BF" (between frames) is used.
Crossmember	Structural member, which is assembled between two side channels of a conveyor bed.
Frame	The structure, which supports the components of a conveyor bed consisting of formed channel rails, bolted together with crossmembers.
Guardrail (GR)	A guardrail is a railing that is placed along the edge of the conveyor, so that the conveying product will not fall over the edge.
Hanger	The term "hanger" shall mean the member qualified to suspend the conveyor from the existing structure (wood joists, steel bar joists ...).
Cross Pipe	A cross-shaped segment used to connect the ends of four pipes.
RF (Roll Formed) Support	RF Supports are constructed from roll-formed components.
RF Heavy Duty (HD)	The Heavy Duty RF support category has higher weight capacity over the standard support product category.
Roller Centers (RC)	Distance between centerlines of adjacent rollers. For curves, roller centers are measured at the inside radius.
Roller Groove	The groove that is fabricated into the carrying roller to provide a seat for the slave belt below the carrying surface.
Tapered Roller	A conical conveyor roller for use in a curve with end and intermediate diameters proportional to their radius.
Top-of-Roller (TOR)	This is the distance from the floor to the top-of-the roller.
Top-of-Belt (TOB)	This is the distance from the floor to the top-of-belt roller.
Zone	A portion of conveyor activated by a motorized roller that may be controlled by a photo eye.
Zone Length	The distance between sensing devices (typically containing one motorized roller).



Transport & Installation

This page is left blank intentionally

6 Transport and Installation

6.1 General Warnings

General warnings are specified throughout the manual to emphasize information of significant importance.

 DANGER	
	<p>Danger!</p> <p>DO NOT transit under suspended loads.</p>
<p>Indicates a high level potentially hazardous situation which, if not avoided, will result in death or serious injury.</p>	

NOTICE	
	<p>Important!</p> <ul style="list-style-type: none"> Lifting and handling must only be done by specialized and trained personnel, who are qualified to perform these activities. Safety briefing of installation personnel according to occupational health and safety protection plan. FORTNA shall not be held liable for any damage, to things or people, caused by accidents due to a failure to comply with the instructions provided in this manual and in the following chapter.
<p>Failure to follow these instructions can result in property damage or equipment damage.</p>	

WARNING



Warning!

- The Installation Supervisor must be experienced with conveyor, qualified in the mechanics of the equipment, and enforce safe working procedures for the protection of the crew, customer, and customer's property.
- The installation must only be carried out by trained and qualified personnel.
- The responsibility for the correct realization of the installation work resides with the personnel entrusted with installation.
- Before restarting a conveyor, which has been stopped because of an emergency, an inspection of the conveyor must be conducted, and the cause of the stoppage determined. The starting device must be locked out before any attempt is made to correct the cause of stoppage.

Indicates a medium level potentially hazardous situation that, if not avoided, could result in death or serious injury.

6.1.1 Packaging

The partly completed machine is shipped by FORTNA from the production plant to that of the Business Partner or End User/Customer. Depending on the transport distance, on the specific Customer requests and on the amount of the load will remain in the packaging, the partly completed machine is shipped as follows:

- Normal protective packaging for short and medium distances.
- Special protective packaging for long distances.

Shipment must be made using covered or sheeted transport means, depending on the type of load. Upon receipt of the partly completed machine, the customer must verify that there is no damage caused by the method of transport or by the personnel in charge of the specific operations.

ACCESSORIES/PARTS	PACKING DEMINIONS (cm)	APPROXIMATE WEIGHT (kg)
Accessories/Parts	122x81x63	800/skids
Parts skid	310x66x51	1000/skids
RF Supports	Min 32" X 48" box on skid	Min 250 to Max 800 per skid

NOTICE



Important!

- Packaging weight, size, and dimension will vary depending on crates built for each product size and quantity packaged.
- RF Supports weight and size will vary by length and quantity stacked.

Failure to follow these instructions can result in property damage or equipment damage.

NOTICE



Important!

If damage is found, leave the found packaging and immediately contact the relevant shipping company for a damage assessment and then inform your distributor immediately.

Failure to follow these instructions can result in property damage or equipment damage.

6.1.2 Packaging Removal

Place the partly completed machine or its components in its intended place.

Unpack the parts delivered with crate, as follows:

1. Remove the straps.
2. Remove screws.
3. Remove stable 2x4 boards.
4. Remove the heat-shrink cellophane.
5. Remove the crate.
6. Remove any fastening systems to the wooden platform.

Unpack the parts delivered on pallets, as follows:

1. Remove the straps.
2. Remove the heat-shrink cellophane.
3. Remove any fastening systems to the wooden platform.

6.2 Disposal of Packaging

The packing is an integral part of the supply; its disposal is the purchaser's responsibility.

The disposal or destruction must comply with the regulations in force in the user's country, bearing in mind the nature of the materials:

- Wood for the crates.
- Plastic film for the protection of the partly completed machine and adhesive tape for their fastening.
- Absorbing bags for the moisture.

7 Transport and Handling

The handling procedures described in this paragraph shall be carried out by staff trained for such operations: suitably trained to safely perform loading, unloading, and handling operations by means of lifting equipment.

Transport Operations

NOTICE	
	<p>Important!</p> <ul style="list-style-type: none"> The lifting personnel must be authorized and trained to use the lifting equipment and devices and must comply with the applicable regulations for personal protection. FORTNA refuses any liability for any damage to the partly completed machine arising from failure to comply with the instructions provided.
<p>Failure to follow these instructions can result in property damage or equipment damage.</p>	

Transport of Conveyor Modules

TRANSPORT REQUIREMENTS	
NO OF QUALIFIED OPERATOR	No. 2 Lifting equipment operator
PPE REQUIRED	
LIFTING EQUIPMENT	Electrical or Propane Forklift per your approved lifting equipment.
FORKLIFT TOOL TO BE USED	Forklift extenders
HANDHELD TOOLS TO USE	<ul style="list-style-type: none"> Banding cutters Torx T25 bit and cordless drill Forklift extensions

NOTICE



Important!

- Must read all manuals. Original language is in English. Visit: fortna-conveyor.com
- Manuals must stay with a partially completed machine or completed machine.
- All safety rules must be observed when working with, on or at the conveyor system in whatever way. This includes reading all Installation, Operation, Maintenance manuals.

Failure to follow these instructions can result in property damage or equipment damage.

CAUTION



Caution!

- Only use suitable and approved lifting equipment, compatible with the dimensions and weight of the component to be handled.
- Make sure nobody stops within the range of the lifting equipment.

Indicates a low level potentially hazardous situation which, if not avoided, could result in minor or moderate injury. It may also be used to alert against unsafe practices or for the protection of the equipment.

NOTICE



Important

- Only trained and license person is allowed to drive the fork truck.
- Always know and follow your forklift operating procedures, safety guidelines and legal requirements.
- The lifting personnel must be authorized and trained to use the lifting equipment and devices and must comply with the applicable regulations for personal protection.

Failure to follow these instructions can result in property damage or equipment damage.

DANGER



Danger!

Must Not

- It is forbidden to ride on forks or anywhere on the fork truck that is not intended for people to ride, sit, or stand.

Indicates a high level potentially hazardous situation which, if not avoided, will result in death or serious injury.

7.1 Unloading Instructions

Step 1)

Checking the Load for Damage

- 1) Examination immediately following unloading will show if any damage was caused during shipment. If damage is evident, claims for recovery of expenses to repair damage or replace components must be made against the carrier immediately.
- 2) While unloading, a check must be made against the Bill of Lading, or other packing lists provided, to confirm full receipt of listed items.



Step 2)

Unloading Crates Using a Forklift

- 1) Drive safely into skid at bottom being careful not to drive too far into the load with the extended forks.
- 2) Lift skid and tilt backward to take the weight of the skid off the floor.
- 3) Drive skid off the container.
- 4) Place skid in designated unloading/unstacking area.
- 5) Remove banding between top skid and bottom skid.
- 6) Unstack skid by using forklift at the entry point of the top skid.

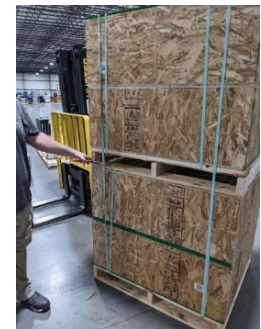
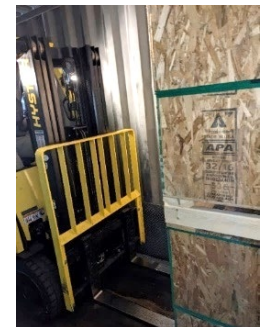

- 7) Lift skid and place next to bottom skid
- 8) Cut and remove the rest of the banding.



- 9) Remove the screws on the top and sides of the crate with a Torx T25 bit and cordless drill.
- 10) Lift the 2x4 support board out of the crate.



7.1.1 Visual of Packing Units

Packaging may vary per the partly completed machine.

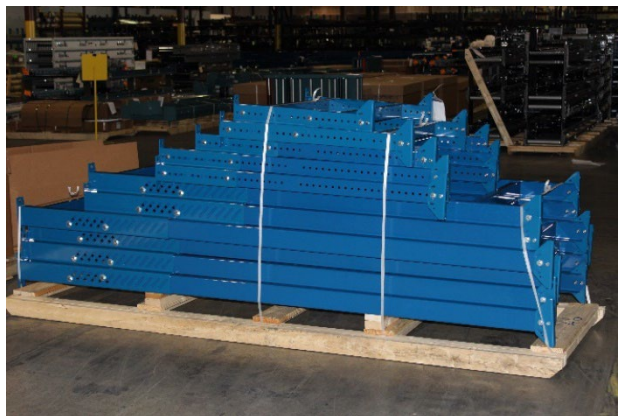

7.2 Disposal of Packaging

The packing is an integral part of the supply; its disposal is the purchaser's responsibility.

The disposal or destruction must comply with the regulations in force in the user's country, bearing in mind the nature of the materials:

- Wood for the crates.
- Plastic film for the protection of the partly completed machine and adhesive tape for their fastening.
- Absorbing bags for the moisture.

7.3 Staging or Installing with Forklift



- 1) Make sure there is adequate space to move the partially completed machine without interference or obstruction.
- 2) Before moving the partially completed machine make sure to place the forklifts in the center of gravity of the load. If needed change position of the forking or lifting straps to find the center of gravity point. The center of gravity is typically at the center of the machine.

Note: The motors will impact the center of gravity.

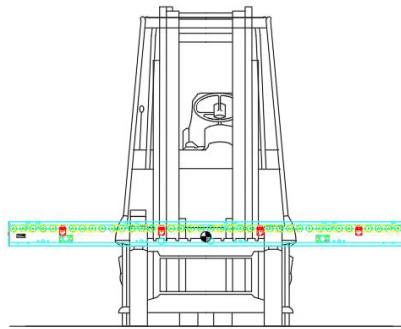

CONVEYOR CENTER OF GRAVITY IS TYPICALLY AT THE CENTER OF THE CONVEYOR.

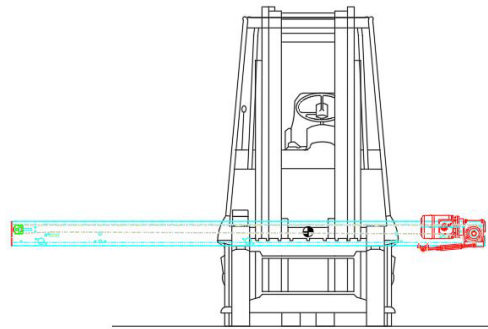

ADJUST CENTER OF GRAVITY FOR CONVEYOR WITH MOTORS.



- 3) If possible, place fork truck forks under the partially completed machine to lift. If not possible, align forks at bottom of partially completed machine, at the center of gravity point. Then slide the partially completed machine onto the forks. Slowly lift the load and perform a stability check.
- 4) Before moving the partially completed machine make sure the load is balanced and secured with straps or clamps to prevent it from falling to the ground.
- 5) Position the conveyor on installed conveyor supports at installation point. Connect conveyor to supports before removing forks

7.4 IntelliROL Receiving & Site Preparation

General

FORTNA IntelliROL units are shipped in subassemblies. These subassemblies are packaged to guard against damage in shipment, when handled properly.

Examination immediately following unloading will show if any damage was caused during shipment. If damage is evident, claims for recovery of expenses to repair damage or replace components must be made against the carrier immediately. While unloading, a check must be made against the Bill of Lading, or other packing lists provided, to confirm full receipt of listed items.

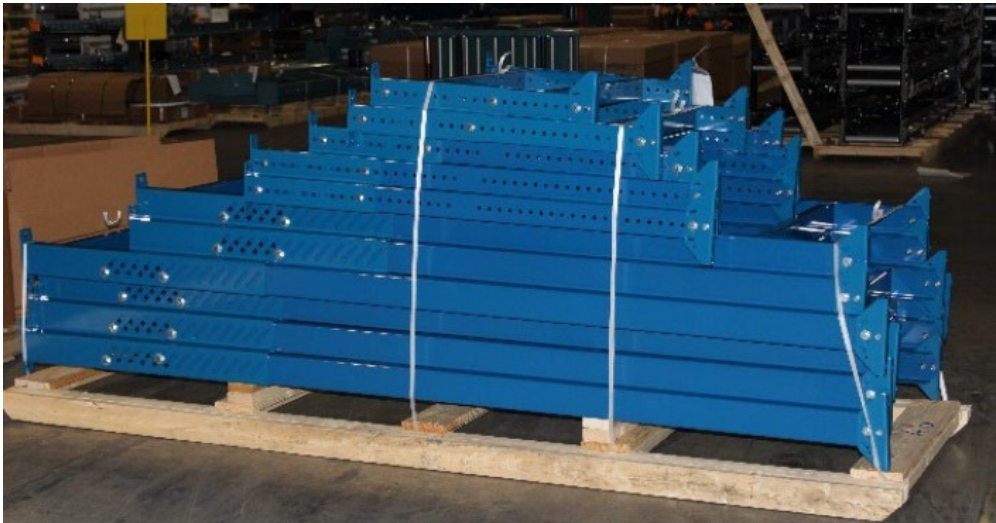

CAUTION



Caution!

TAKE CARE DURING THE REMOVAL OF EQUIPMENT FROM THE CARRIER. Remove small items and boxes first. Pull and lift only on the skid, not on the frame, crossmember or any part of the equipment.

Indicates a low level potentially hazardous situation which, if not avoided, could result in minor or moderate injury. It may also be used to alert against unsafe practices or for the protection of the equipment.

7.5 Preparation of Site

After the conveyor is received, move it to the installation site or designated dry storage area as soon as possible. Clean up all packing material immediately before parts get lost in it. Loose parts should remain in the shipping boxes until needed.

Prior to starting assembly of the partly completed machine conveyor, carefully check the installation path to be sure there are no obstructions that will cause interference. Check for access along the path needed to bring in bed sections and components closest to the point where they are needed. It is often necessary to give the area along the system path a general cleanup to improve installation efficiency, access, and accuracy.

7.6 Parts Inventory & Identification

Each subassembly is shipped completely assembled. Identify and separate components by type or tag number, for inventory and ease of locating during installation.

An identification label is attached to the outside of one side channel or on a cross member, close to one end of each conveyor bed or partly completed machine.



This label contains:

- Tag number (if specified)
- Description
- Item number
- Job Number
- Mfg. Number
- Mfg. Date
- CBC number (Serial Number)
- QR (Quick Response) Label
- Scan Code for IOM Manual



Scan the QR code to retrieve the IOM Manual, if nothing happens; check your scanner settings and make sure the QR Label setting is enabled.

On the supports, the tag is located on the bottom side of the foot. On special devices, it is located on a convenient flat surface that is not offensive to the appearance of the equipment but is still accessible for viewing. These numbers can be cross-referenced against the packing list. Loose parts are boxed and shipped separately.

You should have all conveyor sections and supports for a particular conveyor prior to installation. It is cost-effective to identify and procure any missing parts before they are needed for assembly. Small items like nuts and bolts are weigh-counted and packaged by size and type.

WARNING



Warning!

- The Installation Supervisor must be experienced with conveyor, qualified in the mechanics of the equipment, and enforce safe working procedures for the protection of the crew, customer, and customer's property.
- The installation must only be carried out by trained and qualified personnel.
- The responsibility for the correct realization of the installation work resides with the personnel entrusted with installation.
- Before restarting a conveyor, which has been stopped because of an emergency, an inspection of the conveyor must be conducted, and the cause of the stoppage determined. The starting device must be locked out before any attempt is made to correct the cause of stoppage.

Indicates a medium level potentially hazardous situation that, if not avoided, could result in death or serious injury.

Installation

This page is left blank intentionally.

8 Installation Arrangements

8.1 Arrangements To Be Made by The Customer and Integrator

The Customer normally bears the preparation of the following, except for different contractual agreements:

- Premises (including building work, such as foundations or ducts if required, lighting).
- It is the integrator's responsibility to ensure conformity with all electrical safety aspects of the Machinery Directive.
- Systems up to the partly completed machine power supply points, in compliance with the laws in force in the country of installation and/or required by the Manufacturer.
- All technical specifications requested by the Manufacturer are contained in the contract of sale.
- The Manufacturer declines any liability if the customer is unable to guarantee the technical features of the systems requested in the contract of sale.
- Auxiliary services suitable for the partly completed machine requirements.
- Tools and consumables necessary for assembly and incorporation.
- If required lubricants for starting up the partly completed machine.
- Suitable lifting and handling systems.

Integrator

- It is the integrator's responsibility to ensure conformity with all electrical safety aspects of the Machinery Directive.

8.1.1 Permitted Environmental Conditions

The environment in which the partly completed machine is installed/incorporated and used is indoors, and sheltered against atmospheric agents such as rain, hail, snow, fog, suspended dusts, and combustible dusts.

The work surface must be sufficiently lit so there are no hazards resulting in discomfort, fatigue, stress, eye strain* etc., any other such as mechanical hazard or electrical hazard, due to human error caused by an inability to see clearly. If there are dark areas or differences in level in the workplace, the user must set adequate lighting devices.

Permitted Environmental Conditions

PERMITTED ENVIRONMENTAL CONDITIONS	
AMBIENT TEMPATURES	1C through 38C (35° F / 100°F)
MAXIMUM RELATIVE HUIMIDITY	80% (Without condensation)
INSTALLATION SITE	Industrial warehouse
AMBIENT LIGHTING	Fluorescent or LED
SUPPORT TRAY	Concrete industrial floor

CAUTION



Caution!

- Environmental conditions different from those specified may cause severe damage to the partly completed machine.
- Placing the partly completed machine in facilities that do not fulfil these requirements will cause the warranty to lapse for parts to be replaced.

Indicates a low level potentially hazardous situation which, if not avoided, could result in minor or moderate injury. It may also be used to alert against unsafe practices or for the protection of the equipment.

8.1.2 Prohibited Environmental Conditions

It **must not** be a classified environment or exposed to aggressive agents such as corrosive vapors or sources of excessive heat.

The use of the partly completed machine under conditions other than those listed is **not allowed**. In particular, the installation and operating environment **MUST NOT**:



MUST NOT!

- **Must Not**, be exposed to corrosive fumes.
- **Must Not**, be exposed to excessive humidity (beyond 80%) and quick relative humidity changes (beyond 0.005 p.u./h).
- **Must Not**, be exposed to excessive dust.
- **Must Not**, be exposed to abrasive dust.
- **Must Not**, be exposed to oily vapors.
- **Must Not**, be exposed to explosive powders or gas mixtures.
- **Must Not**, be exposed to salty air.
- **Must Not**, be exposed to anomalous vibrations, collisions, or blows.
- **Must Not**, be exposed to weather conditions beyond allowed limits or dripping.
- **Must Not**, be exposed to unusual transport or storage conditions.
- **Must Not**, be exposed to high or rapid thermal variations (beyond 5K/h).
- **Must Not**, have presence of any radiation.

NOTICE



Important!

Ensuring a good and safe interior environment is the integrator's (or end user's) responsibility.

Failure to follow these instructions can result in property damage or equipment damage.

Installation & Applications

This page is left blank intentionally.

9 IOM Purpose

IOM Purpose

It is the intent of FORTNA, through this manual, to provide information that acts as a guide in the Installation, Operation, and Maintenance of FORTNA conveyors.

This manual describes basic installation practices, assembly arrangements, preventive maintenance, and assists in replacement parts identification.

NOTICE	
	<ul style="list-style-type: none"> Must read all manuals. Manuals must stay with a partly completed machine or completed machine. All safety rules must be observed when working with, on or at the conveyor system in whatever way. This includes reading all Installation, Operation, Maintenance manuals.
Failure to follow these instructions can result in property damage or equipment damage.	

This service manual is intended for use by personnel who are knowledgeable of installation and safe working practices on conveyor systems.

Not all applications and conditions can be covered; therefore, this manual is to be used ONLY as a guide. Proper training of operating and maintenance personnel is required by the owner/operator of the equipment. If additional copies of this manual are needed or if you have any question concerning the conveyor, please contact your FORTNA Distributor or FORTNA Lifetime Services at 231-798-4547 or visit [FORTNA-conveyor.com](https://www.fortna-conveyor.com) for maintenance videos and other application information.

Failure to follow the instructions and cautions throughout this manual and warning label on the conveyor may result in injury to personnel or damage to the equipment.

Your FORTNA is powered by a motor and can be stopped only by turning off electrical power to the motor. As with all powered machinery, the drive-related components – including sprockets, chains, shafts, universal joints, and pneumatic devices – can be dangerous. We have installed or provided guards to prevent accidental contact with these parts, along with warning labels to identify the hazards.

9.1 Tools

9.1.1 Applicable Tightening Torques

Applicable torque settings are specified in all other cases.

HEXAGON BOLTS/SOCKET SCREWS					
PROPERTY CLASS MARKING					
					
NOMINAL DIAMETER	PROPERTY CLASS	TIGHTENING TORQUE		PRELOAD	
		(Nm)	(ft-lb)	(kN)	(LBS)
M4 X 0.7	4.6	1.0	8 (in-lb)	1.5	333
	8.8	2.6	23 (in-lb)	3.8	858
	10.9	3.7	32 (in-lb)	5.5	1,228
M5 X 0.8	4.6	2.0	18 (in-lb)	2.4	538
	8.8	5.3	47 (in-lb)	6.2	1,387
	10.9	7.5	66 (in-lb)	8.8	1,985
M6 X 1	4.6	3.5	31 (in-lb)	3.4	763
	8.8	9.0	79 (in-lb)	8.8	1,968
	10.9	12.8	113 (in-lb)	12.5	2,816
M8 X 1.25	4.6	8.4	6 (ft-lb)	6.2	1,389
	8.8	21.8	16 (ft-lb)	15.9	3,580
	10.9	31.1	23 (ft-lb)	22.8	5,123
M10 X 1.5	4.6	16.7	12 (ft-lb)	9.8	2,200
	8.8	43.0	32 (ft-lb)	25.2	5,671
	10.9	61.5	45 (ft-lb)	36.1	8,115
M12 X 1.75	4.6	29.1	21 (ft-lb)	14.2	3,197
	8.8	74.9	55 (ft-lb)	36.7	8,240
	10.9	107.3	79 (ft-lb)	52.5	11,792

PRELOAD ESTIMATED AS 75% OF PROOF LOAD FOR SPECIFIC BOLT/SCREW TORQUE VALUES FROM T=KDF WHERE; K=0.17 FOR ZINC PLATED AND DRY CONDITIONS

There are points at which torque measurements should be measured.

- RF Supports
- Connection plates

9.1.2 Tools Required

QUANTITY	DESCRIPTION	DIMENSION
1	Dead Blow Hammer	N/A
1	Laser level	N.A.
2	Level	Up to 4ft
1	Measuring tape	N.A.
1	Plumb line (chalk string)	N.A.
1	Plum-Bob or Laser	N/A
2	Screw Clamps	N.A.
2	Socket wrench set	mm
2	Wrench set	mm

NOTICE



Important!

The equipment is designed for one work team.

Failure to follow these instructions can result in property damage or equipment damage.

9.1.3 Other Tools (Optional)

What is marked in the following table is an option to have at the work site for ease of maintenance.

---	---	---



10 Support Arrangements

10.1 Floor Supports

All conveyor bed side channels are punched to match hole spacing for FORTNA standard floor supports. Install bolts used to attach the standhead to the frame so the nut is on the bottom. Standhead bolts should be left finger tight while the conveyor is being assembled and aligned.

Floor supports are ordered by nominal height range, which is the dimension from the floor to top of the support. Conveyor elevations are shown on the layout by top-of-roller elevations. This difference must be recognized when setting the support elevations. IntelliROL conveyor is 6 3/8" from top-of-support to top-of-rollers with a 7 1/2" deep channel. (Rollers mounted low in frame.)

It is important that conveyor frames be installed level. Floor supports will accommodate normal irregularities in the floor surface. Adjustment for elevation in floor supports is accomplished with metal-on-metal bolt clamping force. To achieve the support's stated load rating, it is necessary to tighten the elevation adjustment bolts (3/8" diameter) to 38 ft-lb of torque.

 WARNING	
	<p>Warning!</p> <ul style="list-style-type: none"> All hardware that has been loosened during installation must be retightened to 55 ft-lb (75 Nm)
<p>Indicates a medium level potentially hazardous situation that, if not avoided, could result in death or serious injury.</p>	

Supports should always be installed in the vertical position, and any variations due to conveyor pitch or floor slope will be compensated for in the pivoting standhead of the support.

10.2 Anchoring

Anchoring in concrete floors is accomplished by drilling into the floor and inserting the suitable anchor bolt. The hole diameter and depth must be in accordance with the anchor bolt manufacturer's instructions, and all applicable codes and requirements.

Anchor intermediate floor supports with two anchor bolts, one through each support foot plate using minimum 3/8" diameter anchor bolts. Stagger anchors from the front hole on one side to rear hole on opposite side. For all HD floor supports and standard floor supports over 5, use 1/2" diameter anchor bolts. Increase the number of anchor bolts for equipment subject to impact loads or as superseded by any other applicable code.

10.3 Installing the Conveyor

FORTNA subassemblies are shipped in subassemblies. These subassemblies are packaged to guard against damage in shipment, when handled properly. Usually, the conveyor sub-assemblies consist of intermediate sections, supports or hangers, and accessories.

All installation should be done by FORTNA approved integrators who are qualified installation specialists and understand conveyors and conveyor layout.

Always follow your conveyor layouts designed for your applications. Refer to ([Support Arrangements](#)) chapter for details.

- The electrical wiring and controls should always be the responsibility of experienced, licensed electricians.

To ensure satisfactory performance, follow these instructions during the installation of every section of the conveyor. Some of these instructions are also described in more detail in the following chapters.

10.4 Basic Installation

1. Mark a line on the floor to locate the centerline of the conveyor frame using a chalk line. Refer to ([Dimensional Reference Points](#)) chapter.

Position the frame supports (or ceiling hangers) to the proper elevation (If hanging conveyor modules). Attach the first conveyor section to its supports. Consult the manufacturer Applications Engineering for details with ceiling hanger applications.

2. Position the conveyor module according to the conveyor label information provided.
 - a. **Note:** Each component is identified with an identification label and a flow arrow.
 - b. Always check your conveyor module layouts and align the conveyor modules according to the layout positions.
3. Locate the center of the conveyor carrying surface, using a plumb-bob or laser, align the conveyor to the center line on the floor within a tolerance of 3mm.
4. Level the conveyor section within a tolerance of 1.5mm from the charge end to the discharge end and from side to side. Refer to ([Elevations](#)) chapter for details.
5. Measure across both frame section diagonals to confirm that it is square within 1/16 inch (1.5mm). Refer to the ([Basic Squareness](#)) chapter for details.
6. Anchor the conveyor section in place using the appropriate anchor bolts according to the layout requirements and codes.
7. Position the next frame supports to the proper elevation for the next conveyor section to be installed.
8. Position the next conveyor section according to the conveyor tag information. Align the conveyor section to the previous conveyor section and to the center line of the floor as described in No. 4.
9. Repeat No. 5 and 6 Refer to ([Basic Squareness](#)) and ([Elevations](#)) chapters for more details.

10. Properly align and position the conveyor section, attach the appropriate connector kits, and anchor the sections in place.
11. Connect the 24VDC wiring harness and any other electrical connectors as necessary between the sections.
12. Repeat No. 8 through No. 13 for all additional sections.
13. Install all guard rails, if applicable.
14. Install the air piping and electrical services.
15. Install any required accessories.

10.5 Dimensional Reference Points

The path of each conveyor in the system is determined by establishing a reference point at each end. The centerline of the conveyor is established, and a chalk line is snapped between these points.

Conveyors should be installed with the centerline of the bed matching the centerline of the conveyor path within 1/8" (3mm) of true center. Locate and mark the center of the crossmembers at each end of the conveyor. Use a plumb-bob or laser or other acceptable means to ensure accuracy to the chalk line.

Always carry out a thorough check for any obstructions such as building columns, manholes, etc. It may be necessary to reroute the conveyor to avoid the obstruction. In this case it would be advisable to begin installation at this point, using the obstruction as a reference point (Datum), and install the sections in either direction as required.

All conveyor sections must be checked for squareness prior to installation as "racking" or being knocked out of square may have occurred during shipping and handling.

10.6 Basic Squareness

Basic Squareness Installation

FORTNAs may be installed using any of the supporting arrangements described under supports of this manual. As each bed is installed in the system, level the conveyor from side to side using a bubble level on the roller at each support. The bubble location should be within the level indicator lines of the level. The centerline of the conveyor should not bow to the right or left more than 1/8" (3mm) in either direction from a centerline drawn between the centers of the conveyor end assemblies.

A simple way to check this is to tie a nylon string around the center of the end roller, pull it taut, and tie it to the center of the roller at the opposite end. Put a wood spacer under the string at each end so it does not rest on the rollers. With the taut string centered on each end and suspended above the rollers, check the center of the rollers at each support relative to the string and adjust accordingly. (Note that this must be done after side-to-side leveling of the conveyor at each support.)

When joining bed frames, it is important to align the side channels. Care must be taken to make sure the rollers are level (carrying surfaces) from bed to bed.

All bed frames should be checked for squareness. To check, measure diagonally from corner to corner. Measure the opposite corners in the same manner. If the bed is square, the two measurements will be the same within 1/16"(1.5mm).

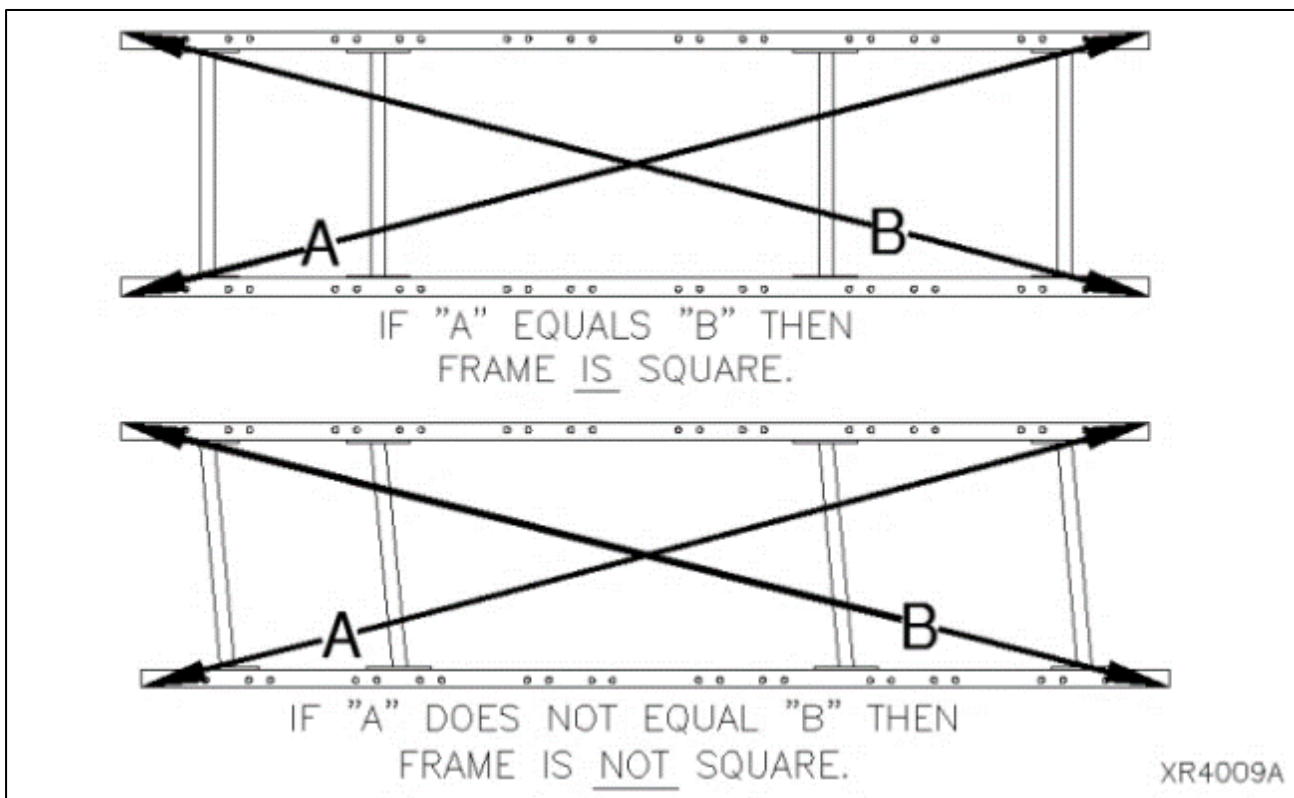

10.7 Elevations



All conveyors should be installed in accordance with the elevations shown on the drawings. In addition, all conveyors must be level across the frame width and length (if horizontal). Leveling of the frames is best done using a rotating laser level or a builder's level.

After the first elevation is established at a critical point, the elevation of all other points shall be relative to this first point. Normal practice is to dimension the layout and measure elevations from the floor at each point of support.

As the conveyor system proceeds onto another floor or into another building or room, a new elevation will be measured from the floor at that point. This new elevation will then become the reference for subsequent elevations.

When installing an overhead system

The first elevation is measured from the floor and becomes the reference elevation point until a change in elevation is shown on the layout. Any new elevation is also measured from the floor and becomes the new reference point. The process is repeated each time an elevation change occurs.

 CAUTION	
	<p>Caution!</p> <p>Consult the building architect or a structural engineer regarding ceiling loading or structural limitations of the building if any conveyor section is ceiling hung.</p>
<p>Indicates a low level potentially hazardous situation which, if not avoided, could result in minor or moderate injury. It may also be used to alert against unsafe practices or for the protection of the equipment.</p>	

10.8 Component Orientation

Using your conveyor system layout drawing and the numbers on the I.D. tags on each component, position and align the conveyor sections, you must know:

- The flow arrow is pointing the direction of product flow
- The elevation height
- Charge and discharge end beds



Product flow arrow

NOTICE



Important!

Do not make alterations to the equipment without consulting with user's representative and FORTNA. Unauthorized modifications to the equipment may impair its function, create a hazardous condition, affect its useful life, and/or void the warranty.

Failure to follow these instructions can result in property damage or equipment damage.

10.9 Establishing Conveyor Flow

Standard conveyor beds are supplied as either RH or LH flow. Flow arrows on conveyor frame indicate direction of product flow. Used to correctly orientate conveyor during installation. Using the same position as noted above and with the product conveying to the left, the bed is considered a left hand (LH) flow bed. The identification label described under [Parts Inventory & Identification](#) has all of the information required to identify the piece of equipment.

NOTICE



Important!

Assure the installation path is clean, dry and clear of obstructions. Use a forklift to move conveyor in place

Failure to follow these instructions can result in property damage or equipment damage.

10.10 Curve Support Points

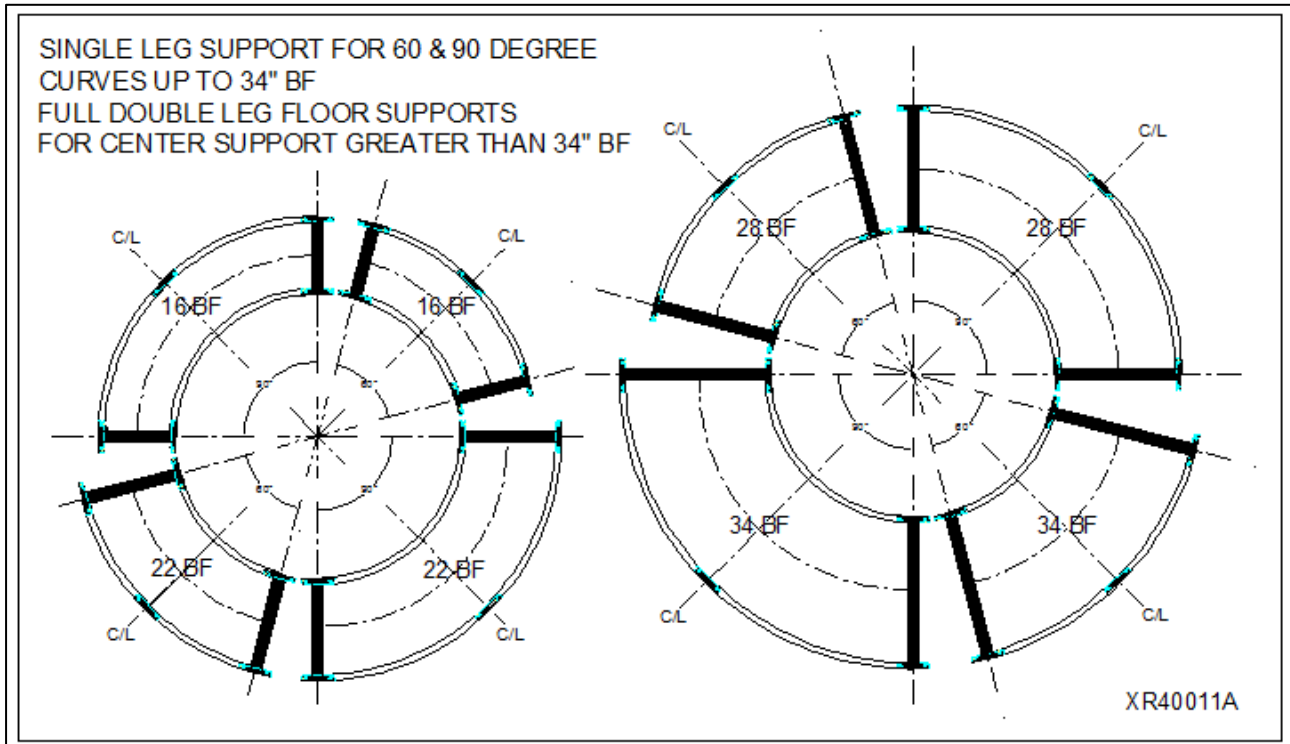

This curve illustration indicates proper support locations for curves of various degrees and widths. The dark lines indicate a full width support. A single dark line on the outside center of the curve indicates that the outer curve rail is supported with either a ceiling hanger drop or a single leg floor support.

If a full width support with crossmember is supplied where only a dark line is indicated, use the full support.

10.11 RF Sway Brace

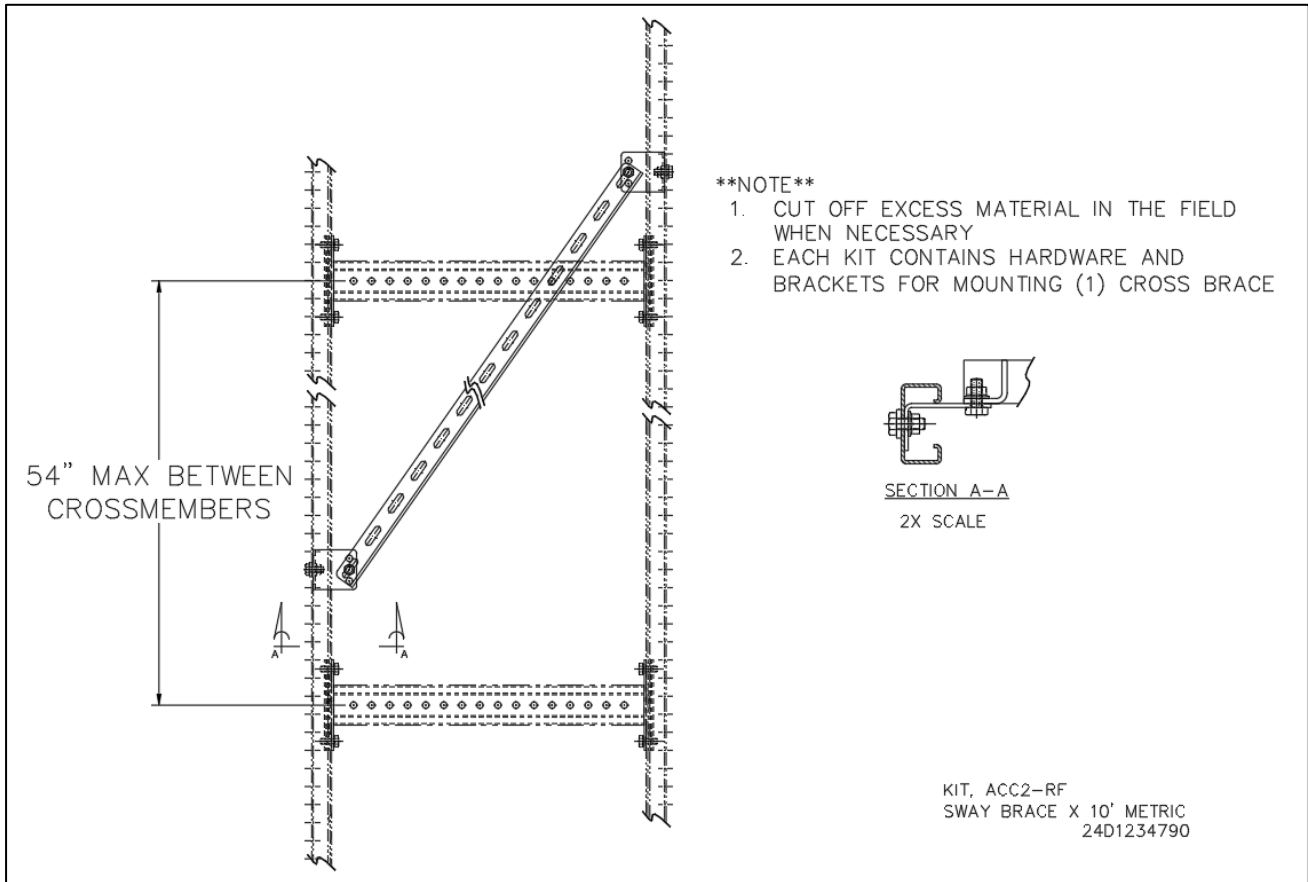

Consists of (2) X-Brace Mounts, (1) Brace 10', and hardware. (Kit P/N#1234790)

There is a tendency for some side-to-side movement in conveyor under certain conditions.

A diagonal sway brace has been designed to reduce side movement through the standard floor support. Side movement is most prevalent in long straight lines which are not side braced by adjoining conveyors, curves, etc., or where they cannot be braced to columns, machinery, or other conveyors. Side forces from different conveyor applications may increase this movement.

One brace can be mounted to every third or fourth support diagonally across the support with the low end on the opposite side of every other brace.

Experience has shown this harmonic condition is most likely to occur between 85 and 120 fpm (on line-shaft for example). If excessive oscillation persists after sway bracing is installed, the conveyor speed may be changed by either increasing or decreasing approximately 15 percent.

Note:

All standard supports are designed with cross bracing already included where needed. Additional sway bracing is considered optional and may be added as needed.

10.12 Basic Floor Support Information

All supports are intended to be used at a conveyor seam or joint at the end of a unit. All CRUZbelt, IntelliROL, NBS, and NBC beds now have butt-bolt connections to allow supporting off center of a bed joint if necessary. Support CRUZbelt at each end and at every splice as shown below. Set all supports for unit to proper height.

Attach supports to both sides of drive.

On intermediate and end beds, attach one support on the end furthest from the drive.

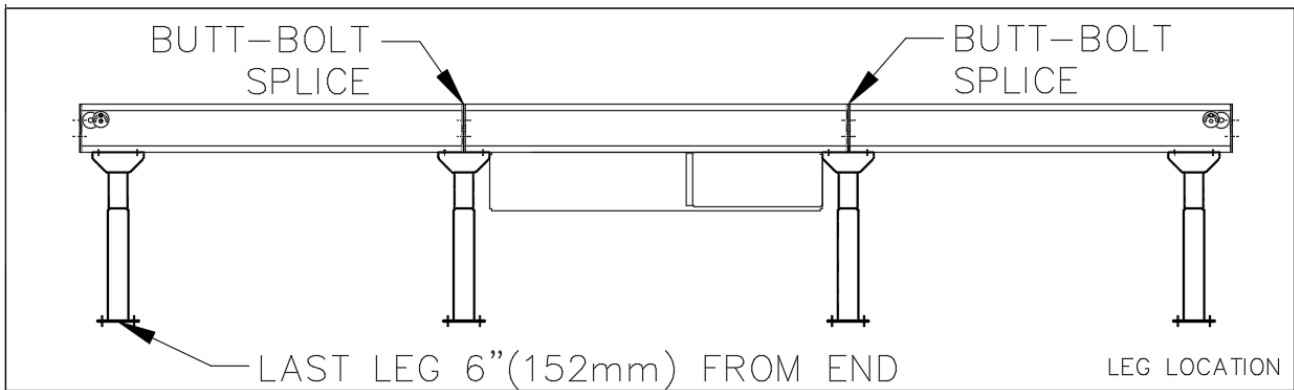

Leg elevations are shown on the elevation drawings. Leg elevation can also be set by subtracting 6-3/8" (162mm) from the desired top-of-belt elevation.

Note:

Top-of-Belt (TOB) 6 3/8" (162mm) = Top of Belt

If knee braces are required, they are installed on approximately 30' centers as shown below.

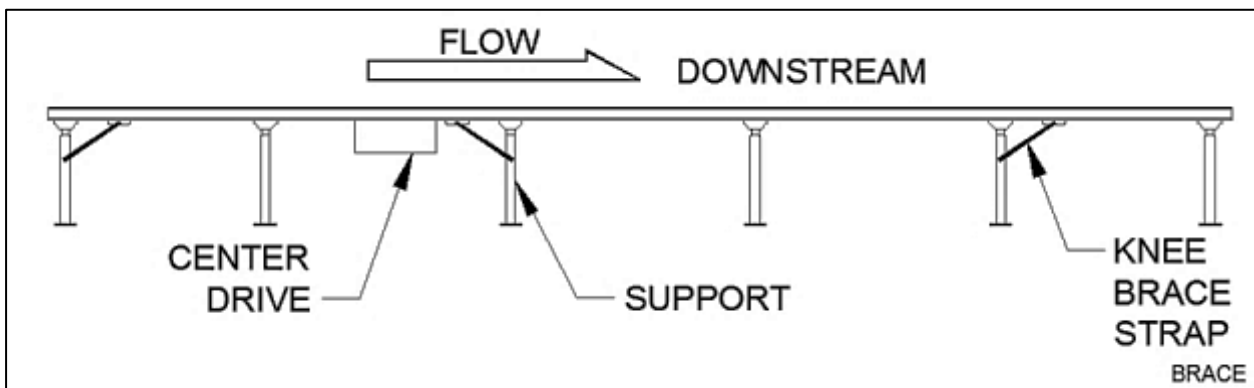

Note the brace direction. Near a drive, the brace should be on the upstream side of the support. Elsewhere the brace should be downstream of the support. For maximum effect, the angle between the brace and the side frame must be between 30 and 45 degrees.

10.13 Basic Conveyor Set Up

Place each bed in position per layout drawing.

Bolt bed butt connectors together.

Set final elevation and level unit. Conveyor must be level side-to-side and along conveyor length as shown below:

Tighten support bolts and anchor to floor.

Install any required guard rail as shown:

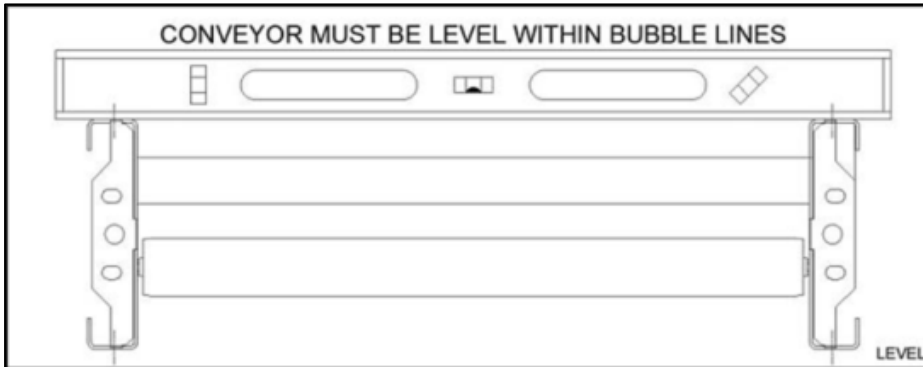

Conveyor must be level

10.14 Guardrail assembly

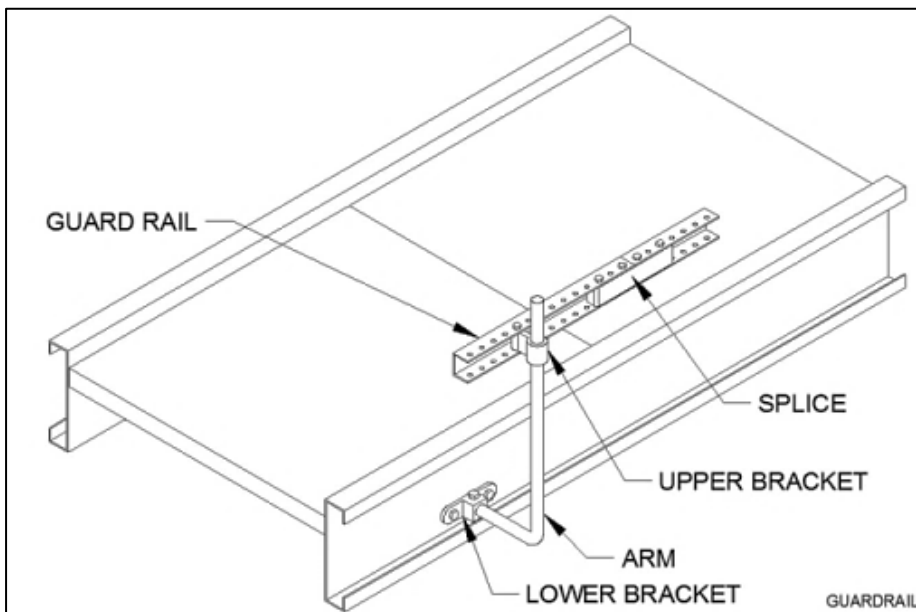

11 Support & Connection Introduction

11.1 Roll Formed (RF) Support Guidelines

Roll Formed (RF) supports replace all existing FORTNA floor supports.

This re-design accomplishes the following objectives:

- The standard floor support, heavy duty floor support, structural heavy duty floor support, multi-deck support, and the structural heavy duty multi-deck support have all been combined into a single roll formed shape configured to the respective applications.
- This “one fits all” approach makes the standard support more robust while dramatically reducing the cost compared to the existing heavy duty and heavy duty structural supports.
- In addition to the simplification of all our supports, the RF support features a modular bolt together design which allows for ease of adjustability and adding cross members to multi-deck supports. The roll formed shape also has a pattern of holes that give flexibility for knee bracing, sway bracing, running safety cables, and hanging of conduit.
- The standard RF support will go up to 17'-7" (536cm) top of the support and the multi-deck up to 18'-6" (563.7cm).
- Standard RF supports replace previous standard heavy-duty, and structural heavy-duty supports.

11.2 RF Heavy Duty (HD) Supports

- **RF Heavy Duty** supports are a newly designed category intended for possible dynamic load applications and conditions.
- **RF Heavy Duty** standard supports go up to 171" (434cm) elevation heights.
- **RF Heavy Duty** Multilevel supports go up to 202.25" (514cm) elevation heights.

Overall, we are confident the RF support program will provide the traditional “**robust**” look and feel FORTNA has always been known for while simplifying the selection process as well as making our heavy duty and tall supports much more competitive.

11.3 Roll Formed Heavy Duty (HD) Support Application Rules

Application Rules – Cruz channels with welded butt bolt connectors:

- Preferred supports at each bed joint.
- Supports on 12' (366cm) centers maximum.
- No more than one unsupported joint on a drive bed.
- Total load on the supports is to be FORTNA systems live loads only. Added equipment weights to be considered by systems system integrator and approved by FORTNA.

Bed joints on intermediate beds can be unsupported (2 max), but only when necessary and using the following guidelines:

- The beds adjacent to the joint are not drive beds.
- The support centers do not exceed 12' (366cm).

Application Rules – Channels without welded butt bolt connectors:

- Supports at each bed joint.

Exceptions:

- Exceptions allowed only if approved by the On-site structural engineer.

Note:

Maximum support crossmember center distance not to exceed 54" (1.37m). All hardware that has been loosened during installation must be retightened to 55 ft-lb (75 Nm) Failure to do so could cause structural failure.

WARNING:

If RF Heavy Duty supports are used for "Seismic" conditions or ratings it shall be noted:

- Compliance assurance per all application codes and requirements is by others.
- FORTNA can provide drawings as needed to Systems Integrator for proper evaluation and approval by their Structural Engineer.

11.4 RF Supports Features & Benefits

Bolt-together construction

- Allows installation flexibility.
- Can remove & re-install upright or cross-member to fit around existing equipment.
- Adjust cross-member heights to simplify mounting of cable trays, conduit, piping, etc.

Note!

Any changes or alterations must be in accordance with published application and safety guidelines.

Mount to options

- Roll formed hole patterns on uprights and cross-members provide easy mounting for FORTNA supplied parts such as knee braces and sway bracing.
- Allows easy attachment of other components such as: conduit, safety cables, wiring, signage, small control boxes, etc.
- Consult with FORTNA engineering if there are any concerns with the size or configuration of add-on items.

Increased capacity

- Replaces previous “heavy duty” style.
- More capacity than “FS” style supports.
- Evaluate case by case for applications outside standard application parameters.

Increased standard height range

- Up to 17'-7" (539cm) for single
- Up to 18'-6" (564cm) for multi-tier
- Replaces the need for ceiling hangars and additional decking in many cases.
- Decreased cost for tall supports and supports previously defined as “heavy duty” structural steel construction.

RF Heavy Duty Supports

- Designed for dynamic load applications and conditions.

11.5 Conversion Chart

1 inch (1") = 25.4 mm

1 foot (1') = 304.8mm

1 foot (1') = 12 inch (12")

12 Roll Formed (RF) Floor Supports

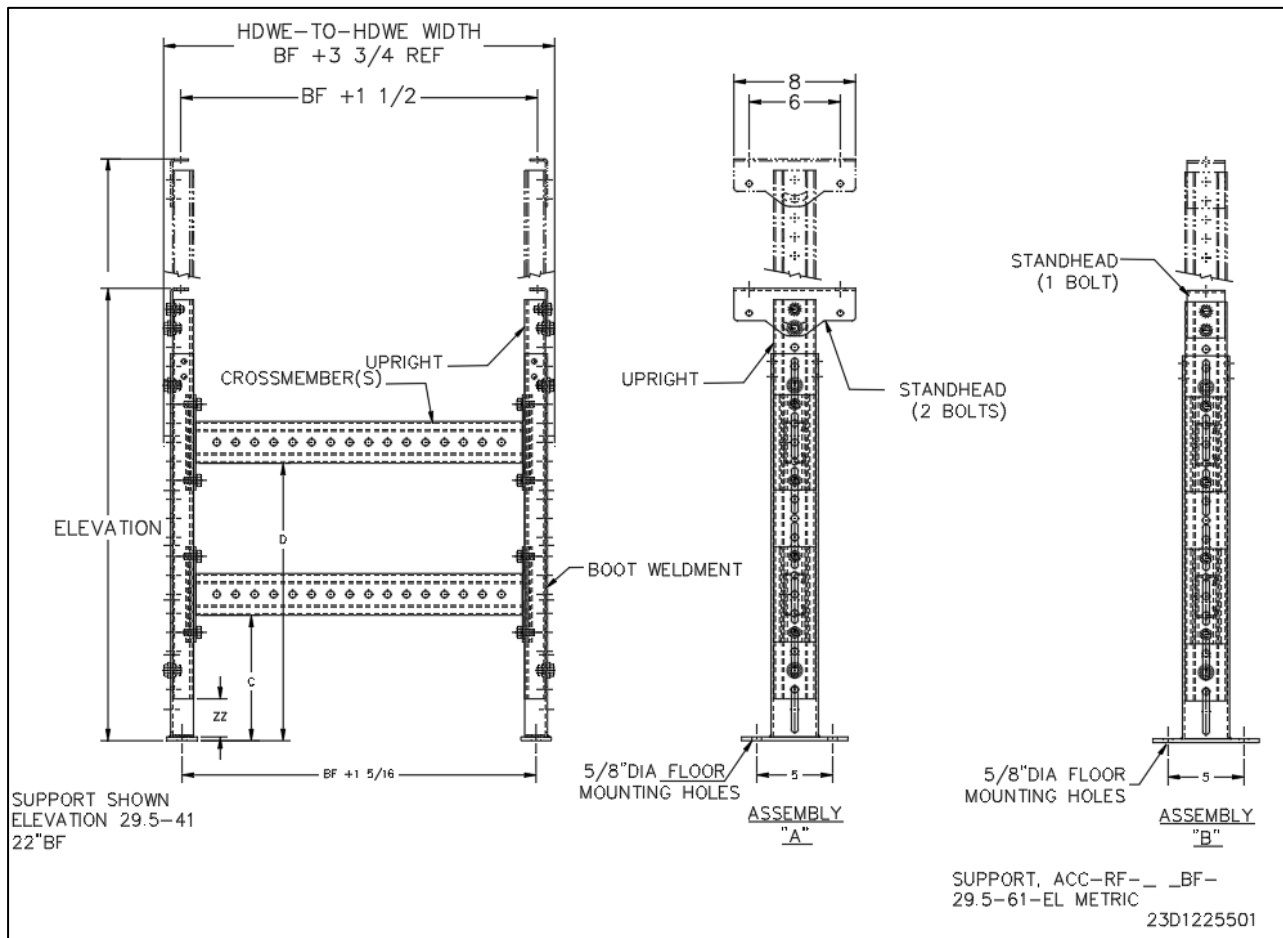

12.1 Standard Equipment

Consists of (2) standheads, (2) legs upright with bolt in crossmember(s), and (2) boot weldments with footplates.

Note:

Maximum support crossmember center distance not to exceed 54" (1.37m). All hardware that has been loosened during installation must be retightened to 55 ft-lb (75 Nm) Failure to do so could cause structural failure.

Capacity:

1500 lb (680kg), typical

Welded butt joints:

FORTNA with welded butt joints has been designed to be supported on 12' (366cm) centers maximum. Drive Beds must be supported at bed joints. For other support locations contact Applications Engineering for assistance.

Bolted butt joints:

FORTNA with bolted butt joints has been designed to be supported at every bed joint.

If unable to support at bed joints, order connection kits for bed joints or approved trussing (priced & available separately). Contact Applications Engineering for assistance.

Note:

Block or support bed while adjusting heights.

Total load on supports is to be FORTNA and system live load only. Added equipment weights to be considered by System Integrator and approved by FORTNA.

The capacities listed are based on both the weight of the conveyor and the product load. Weights that are not centered will reduce the capacities.

Shipping:

All floor supports are shipped un-assembled in crates.

Height range shown is to top of support:

Add 4-7/8" (124mm) for top-of-roller (TOR) when conveyor has 4.5" Channels.

Add 6-3/8" (162mm) for TOR when conveyor has 7.5" CRUZ or C6 channel.

Add 9-3/8" (238mm) TOR when conveyor has 9" Channels.

13 RF HD Floor Support 18.5 (46.9cm) thru 30.5 (77.4cm) Elevation

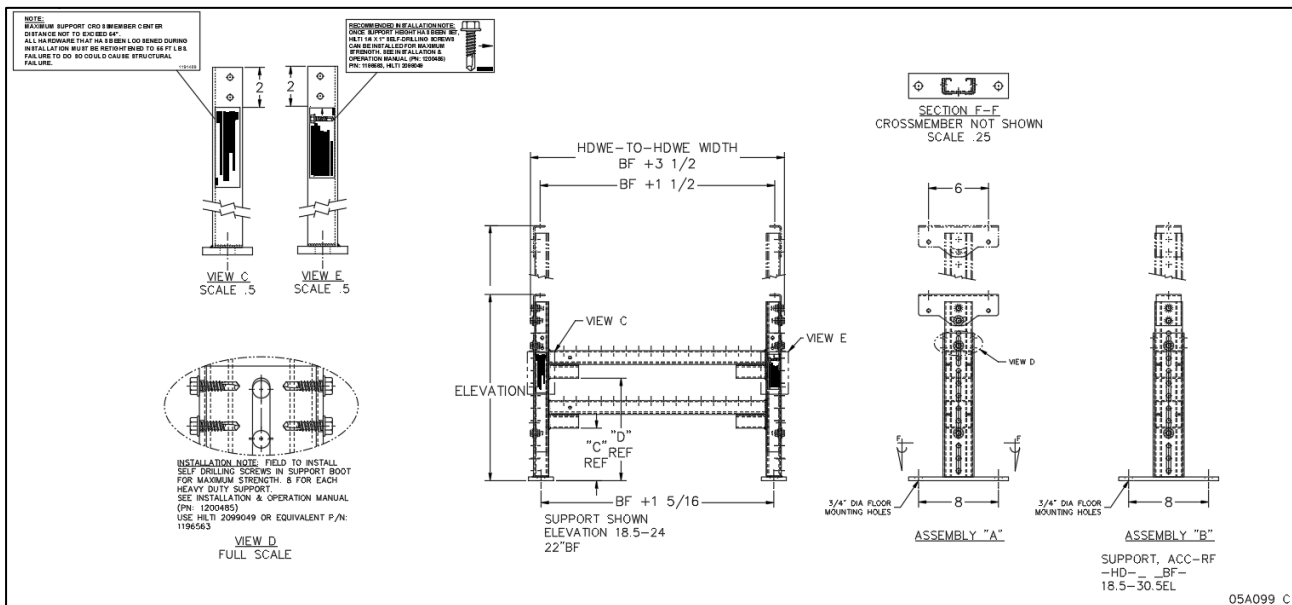

Standard Equipment

Consists of (2) standheads, (2) legs upright with welded H-frame crossmember(s), and (2) boot weldments with footplates.

Note:

All hardware that has been loosened during installation must be retightened to 55 ft-lb (75 Nm) Failure to do so could cause structural failure.

Static Capacity:

1500 lb (680kg), typical

Dynamic Capacity:

To be determined by local Structural Engineer

Dynamic Load Testing

Note:

To be determined by local Structural Engineer

WARNING:

If RF Heavy Duty supports are used for "Seismic" conditions or ratings it shall be noted:

- Compliance assurance per all application codes and requirements is by others.
- FORTNA can provide drawings as needed to Systems Integrator for proper evaluation and approval by their Structural Engineer.

Welded butt joints:

FORTNA with welded butt joints has been designed to be supported on 12' (366cm) centers maximum. Drive Beds must be supported at bed joints. For other support locations contact Applications Engineering for assistance.

Bolted butt joints:

FORTNA with bolted butt joints has been designed to be supported at every bed joint.

If unable to support at the bed joints, order connection kits for bed joints or approved trussing (priced & available separately). Contact Applications Engineering for assistance.

Note:

Block or support bed while adjusting heights.

Total load on supports is to be FORTNA and system live load only. Added equipment weights to be considered by System Integrator and approved by FORTNA.

The capacities listed are based on both the weight of the conveyor and the product load. Weights that are not centered will reduce the capacities.

Shipping:

All floor supports are shipped un-assembled in crates.

13.1 RF HD Application for Maximum Strength

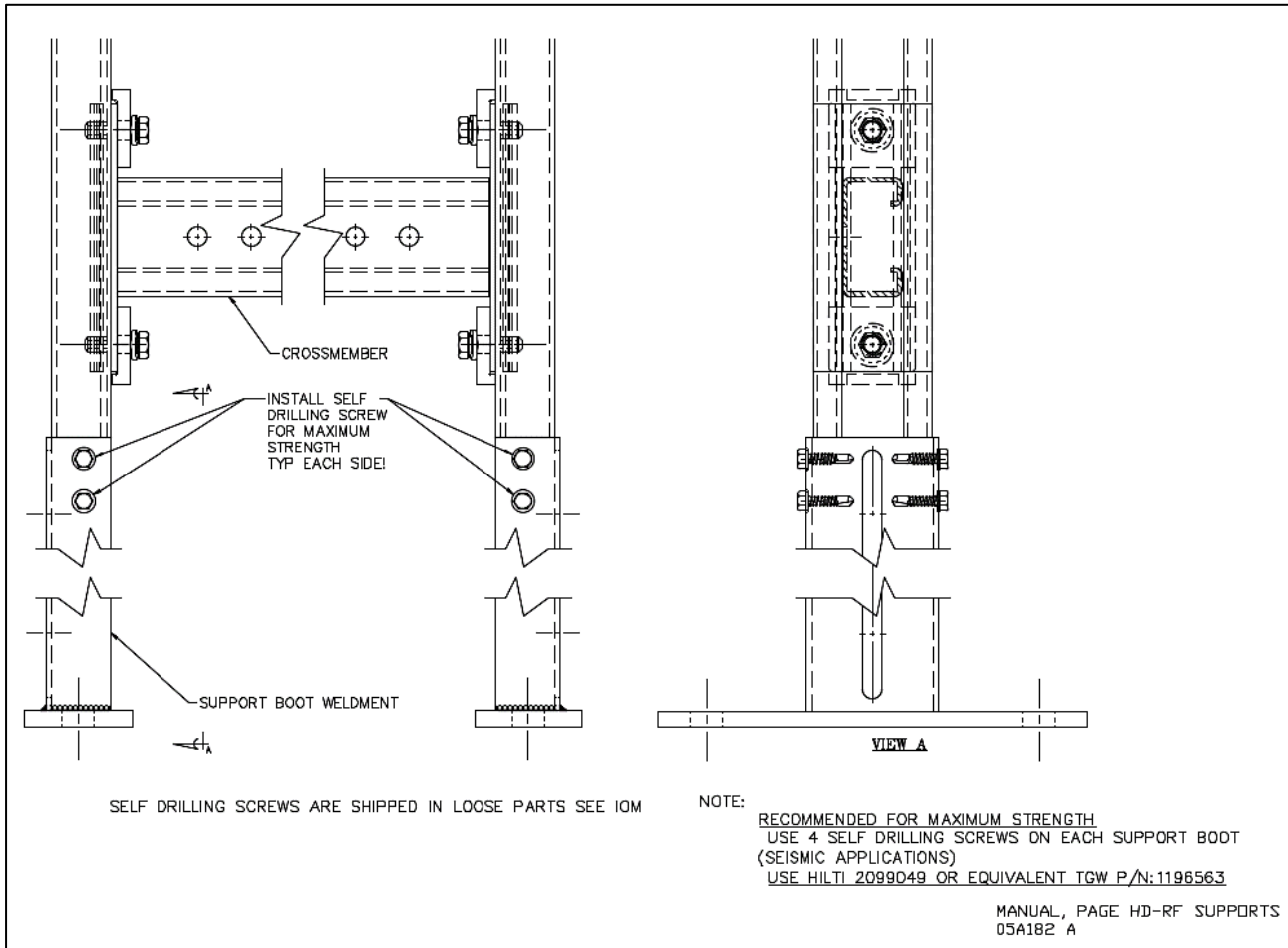

WARNING:

If RF Heavy Duty supports are used for “Seismic” conditions or ratings it shall be noted:

- Compliance assurance per all application codes and requirements is by others.
- FORTNA can provide drawings as needed to Systems Integrator for proper evaluation and approval by their Structural Engineer.

Note:

Maximum support crossmember center distance not to exceed 54” (1.37m). All hardware that has been loosened during installation must be retightened to 55 ft-lb (75 Nm) Failure to do so could cause structural failure.

13.2 RF HD Floor Support 146.5 (372.1 cm) thru 171 (434.3cm) Elevations

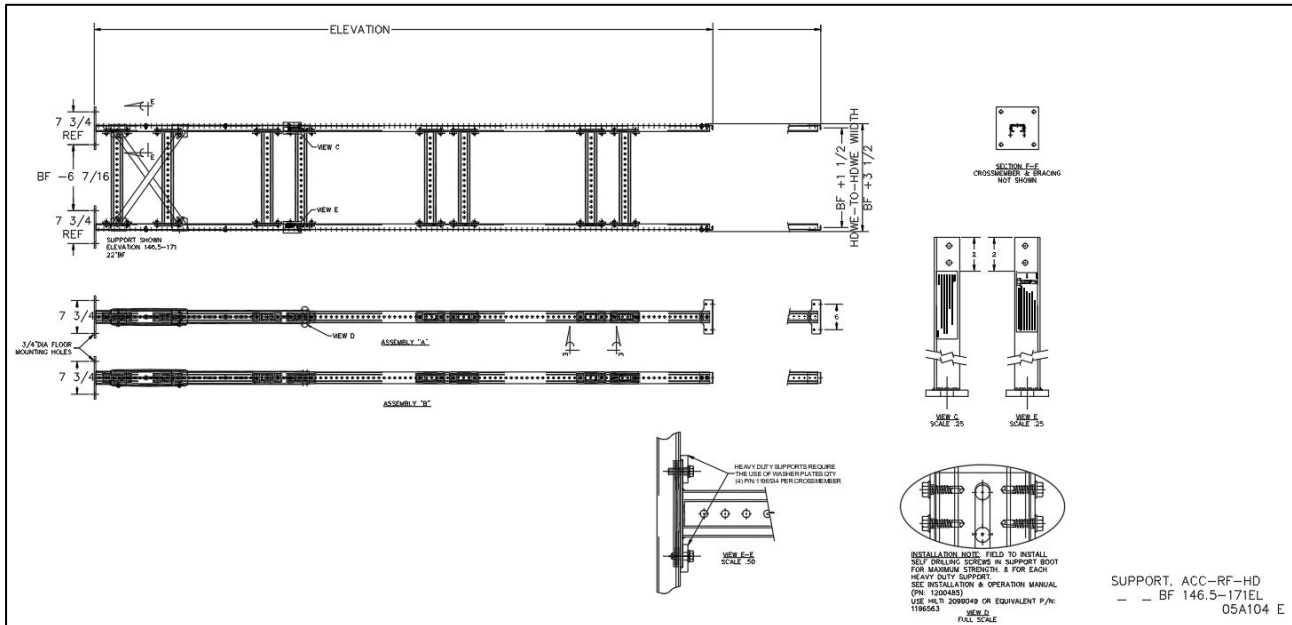

Standard Equipment

Consists of (2) standheads, (2) legs upright with bolt in crossmember(s), and (2) boot weldments with footplates.

Note:

Maximum support crossmember center distance not to exceed 54" (1.37m). All hardware that has been loosened during installation must be retightened to 55 ft-lb (75 Nm) Failure to do so could cause structural failure.

Static Capacity:

1500 lb (680kg), typical

Dynamic Capacity:

To be determined by local Structural Engineer

Dynamic Load Testing

Note:

To be determined by local Structural Engineer

WARNING:

If RF Heavy Duty supports are used for "Seismic" conditions or ratings it shall be noted:

- Compliance assurance per all application codes and requirements is by others.
- FORTNA can provide drawings as needed to Systems Integrator for proper evaluation and approval by their Structural Engineer.

Welded butt joints:

FORTNA with welded butt joints has been designed to be supported on 12' (366cm) centers maximum. Drive Beds must be supported at bed joints. For other support locations contact Applications Engineering for assistance.

Bolted butt joints:

FORTNA with bolted butt joints has been designed to be supported at every bed joint.

If unable to support at bed joints, order connection kits for bed joints or approved trussing (priced & available separately). Contact Applications Engineering for assistance.

Note:

Block or support bed while adjusting heights.

Total load on supports is to be FORTNA and system live load only. Added equipment weights to be considered by System Integrator and approved by FORTNA.

The capacities listed are based on both the weight of the conveyor and the product load. Weights that are not centered will reduce the capacities.

Shipping:

All floor supports are shipped un-assembled in crates.

13.3 RF HD Application for Maximum Strength

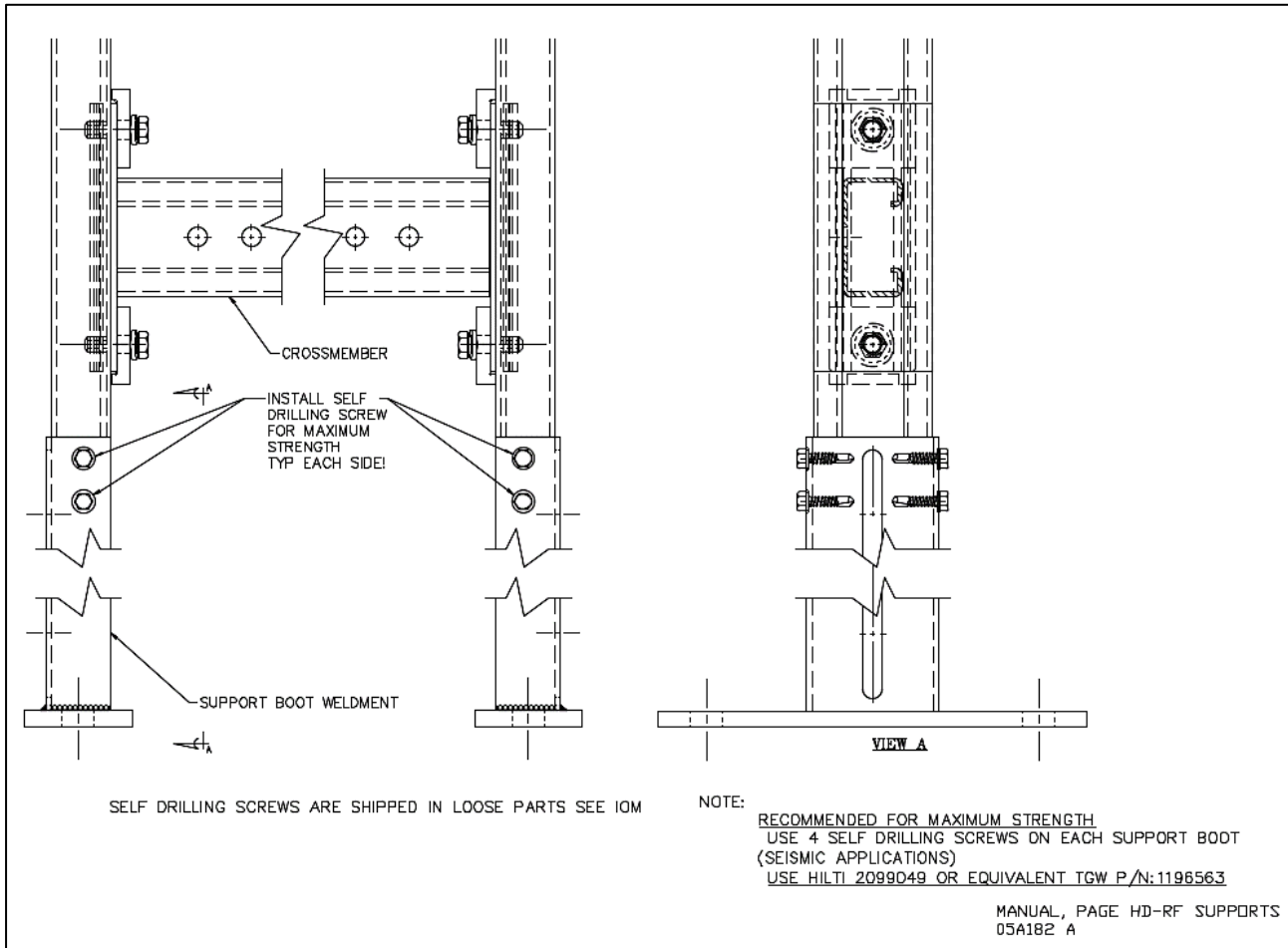

WARNING:

If RF Heavy Duty supports are used for “Seismic” conditions or ratings it shall be noted:

- Compliance assurance per all application codes and requirements is by others.
- FORTNA can provide drawings as needed to Systems Integrator for proper evaluation and approval by their Structural Engineer.

Note:

Maximum support crossmember center distance not to exceed 54” (1.37m). All hardware that has been loosened during installation must be retightened to 55 ft-lb (75 Nm) Failure to do so could cause structural failure.

13.4 RF NBS

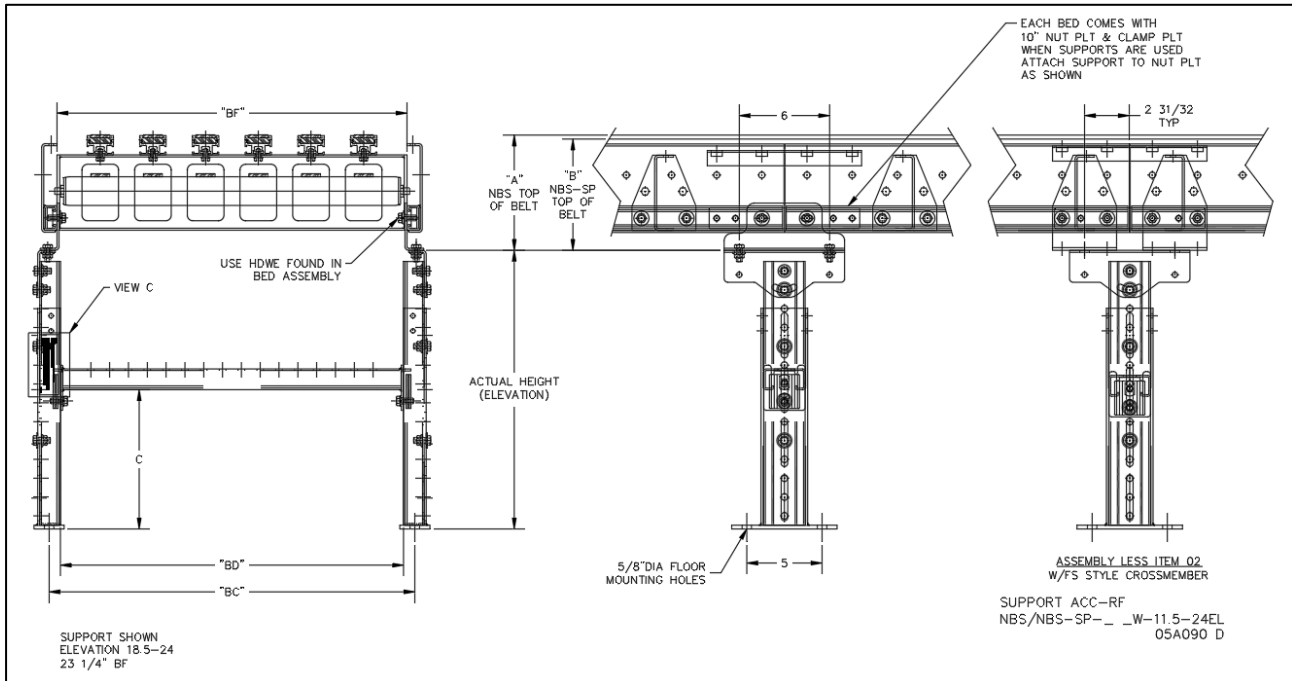

Standard Equipment

Consists of (2) standheads, (2) leg uprights with bolt in crossmember(s), and (2) boot weldments with footplates.

Note:

Maximum support crossmember center distance not to exceed 54" (1.37m). All hardware that has been loosened during installation must be retightened to 55 ft-lb (75 Nm) Failure to do so could cause structural failure.

Capacity:

1500 lb (680kg), typical

Shipping:

All floor supports are shipped un-assembled in crates.

	AMOUNT TO ADD TO ACTUAL HEIGHT FOR TOP OF BELT DIMENSION
NBS CONVEYOR	"A"
NBS INT	7 5/8 (194mm)
NBS 5' AIR TAKEUP	7 5/8 (OAL DEPTH 22" (559mm))
	AMOUNT TO ADD TO ACTUAL HEIGHT FOR TOP OF BELT DIMENSION
NBS-SP CONVEYOR	"B"
NBS-SP INT	7 3/8" (187mm)

REF DWG# 05A090

13.5 NBS Vertibelt RF Supports

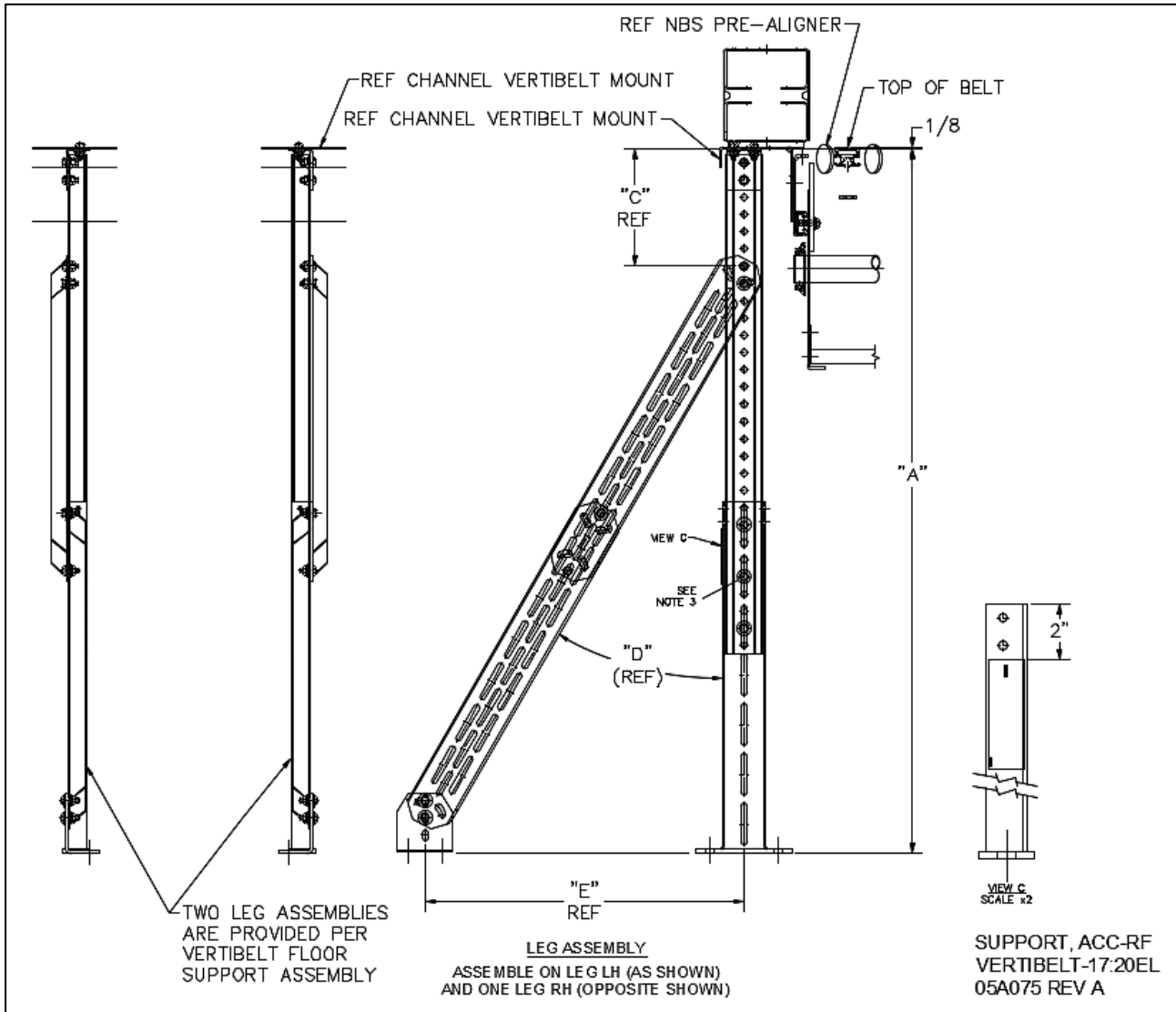

Drawing Notes:

1. Support consists of two leg assemblies (one right hand & one left hand).
2. Two leg assemblies are provided per Vertibelt floor support assembly.
3. Leg supports 86.5-111 thru 106.5-131 (271cm – 333cm) require (3) fasteners evenly spaced securing the boot and the leg.

14 RF Curve Center Support



RF CCS Support

Standard Equipment

Consists of (1) standhead, (1) boot weldment with footplate, and (1) leg upright (less crossmembers) to support outside channel of curves.

Single leg supports should be used on 90° and 60° curves.

Curves over 34BF should install a standard floor support with crossmember, located in center location of curve.

Note:

All hardware that has been loosened during installation must be retightened to 55 ft-lb (75 Nm) Failure to do so could cause structural failure.

Block or support bed while adjusting heights.

Total load on supports is to be FORTNA and system live load only. Added equipment weights to be considered by System Integrator and approved by FORTNA.

The capacities listed are based on both the weight of the conveyor and the product load. Weights that are not centered will reduce the capacities.

14.1 7" (17.8cm) Thru 13" (33cm) RF low elevation support

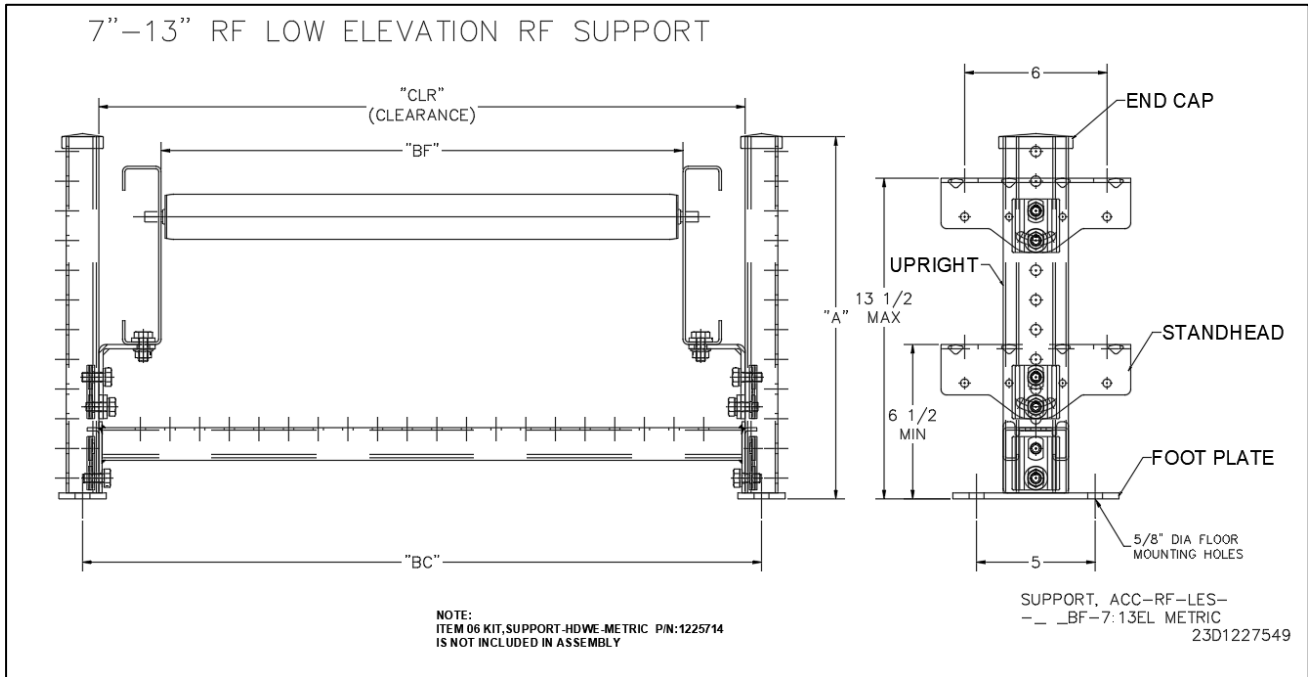

Low elevation supports consist of (2) standheads, (2) leg upright weldments with footplate, (1) crossmember, (2) end caps, and hardware.

Capacity:

750 lb (340kg), typical

14.2 Single Leg 1.5 (3.8cm) Thru 10.5 (26.6cm) Low Elevation Supports

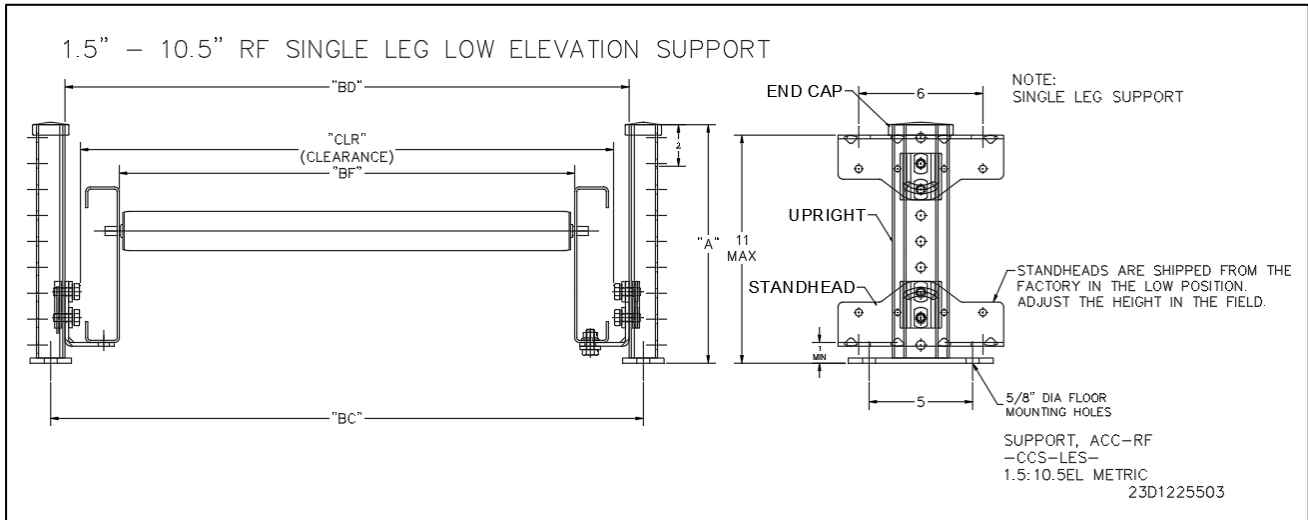

Single Leg Low Elevation Supports consist of (1) standhead, (1) leg upright weldment with footplate, (1) end cap, and hardware.

Locations:

Bracing the conveyor to other structures may be required since the (1.5"-10.5") low elevation support **does not include crossmembers**.

Capacity:

700 lb (318kg), typical

Elevation ranges:

Measured from bottom of footplate to top of conveyor.

1.5-10.5 RF SINGLE LEG LOW ELEVATION SUPPORT				7-13 RF LOW ELEVATION SUPPORT			
Conveyor Type	Channel Type	Top of Conveyor Elevation (INCHES)		Conveyor Type	Channel Type	Top of Conveyor Elevation (INCHES)	
		Minimum	Maximum			Minimum	Maximum
XenoROL®	4.5"	8-1/2"	15"	XenoROL®	4.5"	11-1/2"	17-3/4"
XenoROL®	9"	13"	19-1/2"	XenoROL®	9"	15-3/4"	22-1/4"
XenoROL®	CRUZchannel	*8-3/4"	17"	XenoROL®	CRUZchannel	13"	19-1/4"
XenoPRESSURE®	CRUZchannel	*8-3/4"	17"	XenoPRESSURE®	CRUZchannel	13"	19-1/4"
CRUZbelt	CRUZchannel	*8-3/4"	17"	CRUZbelt	CRUZchannel	13"	19-1/4"
IntelliROL®	CRUZchannel	*8-3/4"	17"	IntelliROL®	CRUZchannel	13"	19-1/4"
Gravity Roller	2.5"	*3-3/4"	13"	Gravity Roller	2.5"	* 6-1/4"	15-1/2"
Gravity Wheel	3.5"	* 5"	14"	Gravity Wheel	3.5"	* 7-3/8"	16-3/4"
NBC	CRUZchannel	*8-3/4"	17"	NBC	CRUZchannel	13"	19-1/4"
* Turn over standhead				* Turn over standhead			
Ref Drawing # 05A086				Ref Drawing # 05A087			

Shipping:

All floor supports are shipped un-assembled in crates.

Note:

Consider the depth of the drive when selecting the correct low elevation support.

15 RF Double-Wide Support

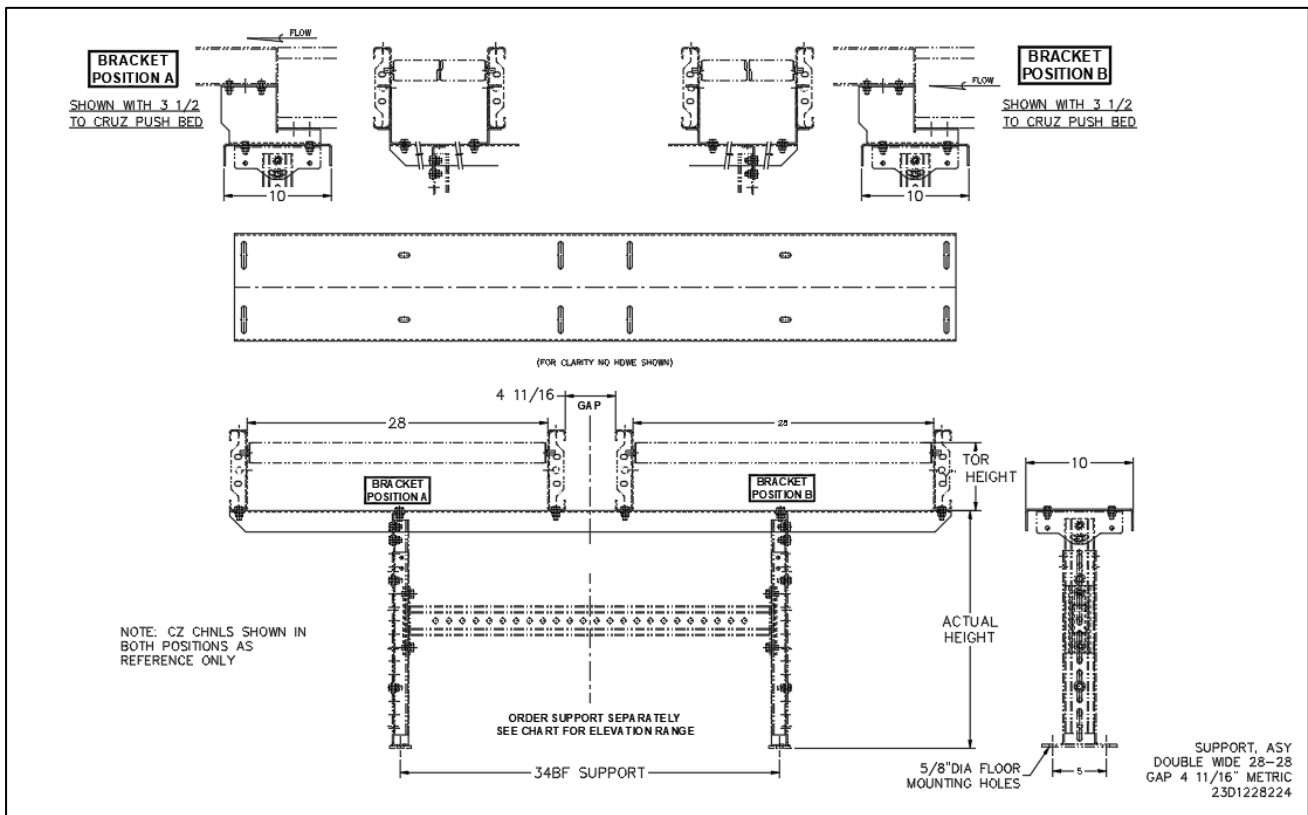

The standard Roll Formed (RF) floor support is also preassembled but not attached to the channel for shipping.

Note:

Maximum support crossmember center distance not to exceed 54" (1.37m). All hardware that has been loosened during installation must be retightened to 55 ft-lb (75 Nm) Failure to do so could cause structural failure.

Capacity:

1500 lb (680kg), typical

RF Channel Spacer Z Bracket for Double Wide:

Consists of 10 ga. formed steel brackets and mounting hardware. Mounting bolts secure bracket to web of side channel. Additional holes may need to be drilled.

	FOR POSITION A & B	ITEM 02
BRACKET HEIGHT	FOR USE WITH CHANNEL TYPE	Z BRACKET
1 1/2	CZ, C6	1196689
1 3/4	CZ LINE SHAFT	1197757
3	9" CH	1197758
3 3/4	GRAV 3 1/2" DP PICK ZONE MOD	1200810
4	GRAV 3 1/2" CH	1196701
4 1/2	XR LINE SHAFT, NBS END W/O ENC	1197759
6 1/2	NBC END, NBS ENC	1197760
NOTES:		
1. CZ CHNLS SHOWN IN BOTH POSITIONS AS REFERENCE ONLY		
2. BEDS ALWAYS REQUIRE BRACKETS.		
3. Z BRACKET ASSEMBLY INCLUDES (2) BRACKETS WITH MOUNTING HARDWARE.		
REF DWG# 23D1228224		

15.1 Hat Channels - Offset

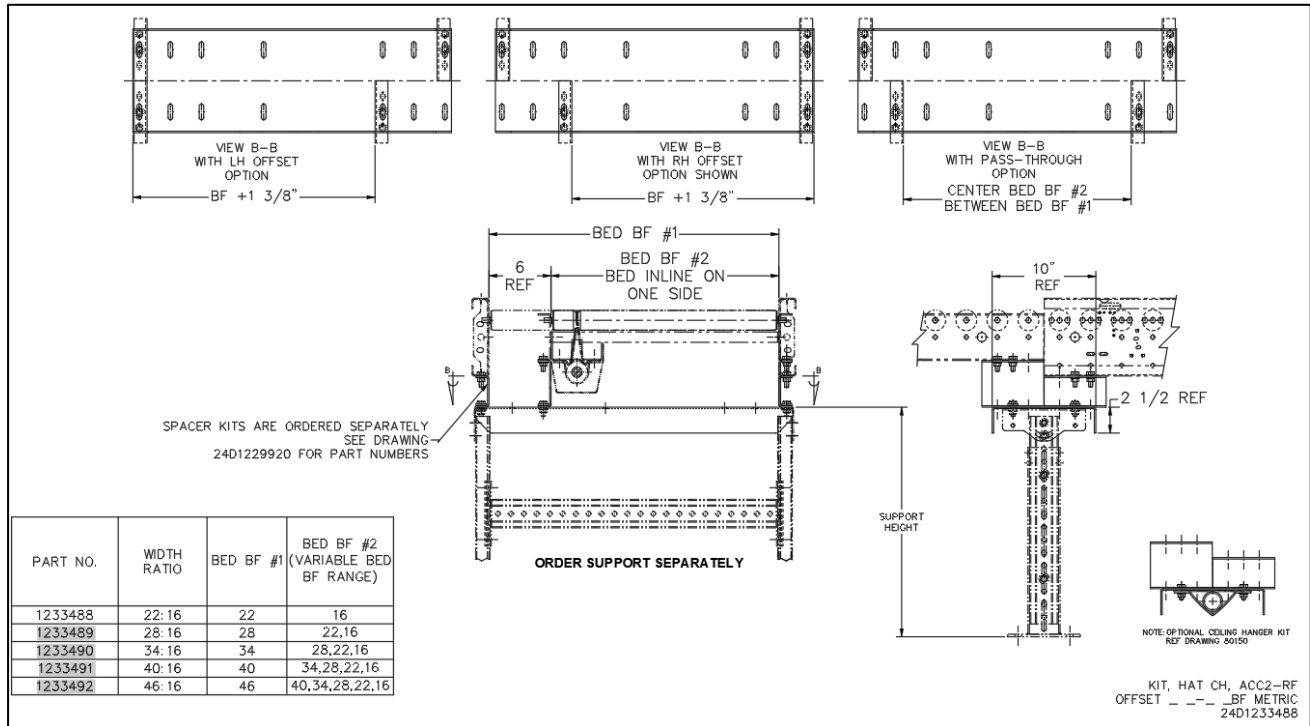

Hat Channel Offset Kit:

KIT, SPACER TRANSITION 1" HIGH THROUGH 6-1/2" HIGH			
KIT, SPACER TRANSITION CHANNEL	FRAME TYPES	SPACER CH P/N	SPACER HEIGHT "A"
1229918	4.5 CH TO 3.5 GRAV	1198690	1"
1234877	4.5 CH TO CZ / C6	1198692	1 1/2"
	PUSH TO CZ / C6 MERGE TO CZ / C6		
1229919	4.5 CH TO 2.5 GRAV	1198693	2"
1229920	CZ / C6 TO 3.5 GRAV	1198694	2 1/2"
1229921	CZ / C6 TO 9 CH	1198695	3"
1229922	CZ / C6 TO 2.5 GRAV	1198696	3 1/2"
1229926	PUSH TO 3.5 GRAV	1198953	4"
1229923	4.5 CH TO 9 CH	1198697	4 1/2"
1229927	PUSH TO 2.5 GRAV	1198954	5"
1229924	9 CH TO 3.5 GRAV	1198698	5 1/2"
1229925	9 CH TO 2.5 GRAV	1198700	6 1/2"

DWG#24D1233488

Consists of 10ga steel channel with hardware. Supports and spacer kits are ordered separate. Mounting bolts secure spacer channels to bottom flange of bed and either the standhead of the floor support or ceiling hanger.

The standard Roll Formed (RF) floor support is also preassembled but not attached to the channel for shipping

Note:

Spacers are shipped with lose parts.

16 RF Triple-Wide Support

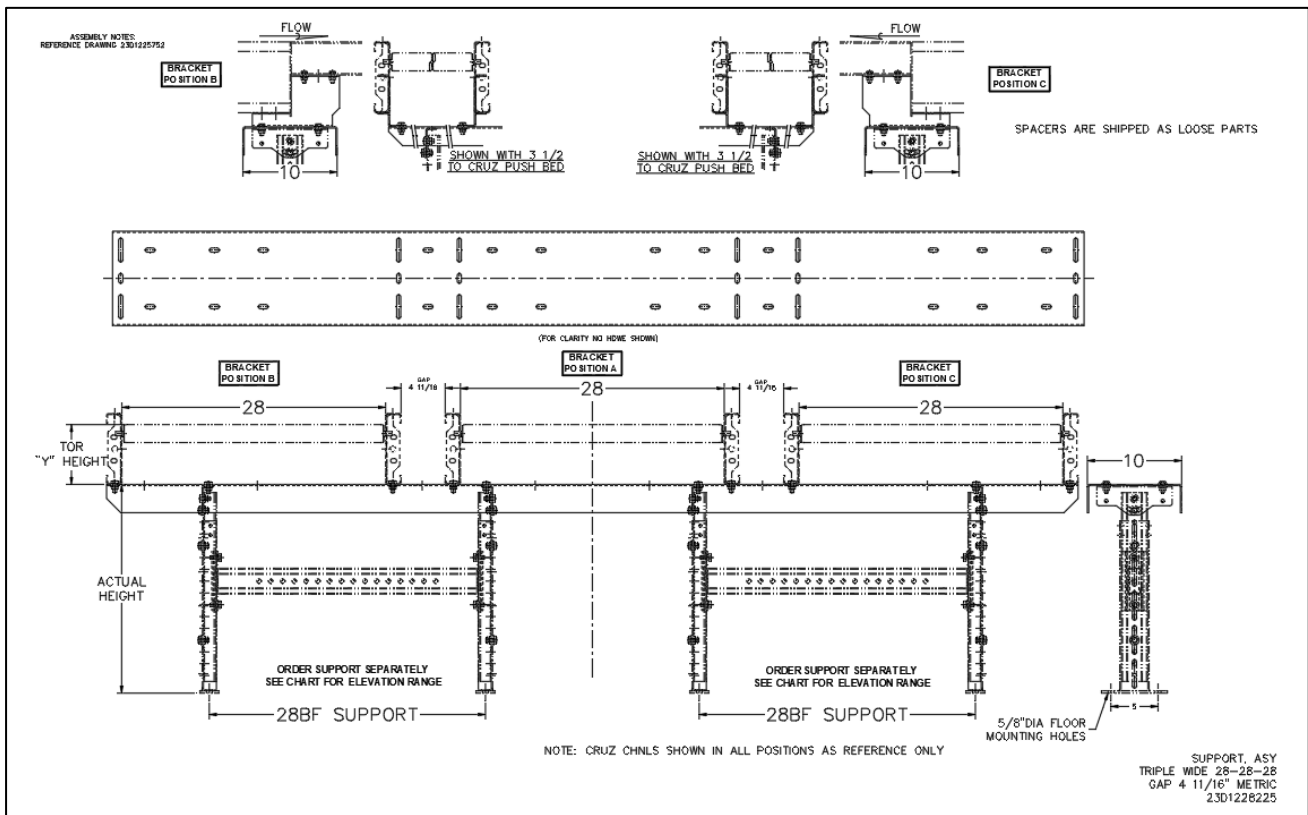

	FOR POSITION A & B & C		ITEM 02
BRACKET HEIGHT	FOR USE WITH CHANNEL TYPE	Z BRACKET	Z BRACKET ASSEMBLY SEE NOTE 4
1 1/2	CZ, C6	1196689	1197761
1 3/4	CZ LINE SHAFT	1197757	1197762
3	9" CH	1197758	1197763
3 3/4	GRAV 3 1/2" DP PICK ZONE MOD	1200810	1201235
4	GRAV 3 1/2" CH	1196701	1197764
4 1/2	XR LINE SHAFT, NBS END W/O ENC	1197759	1197765
6 1/2	NBC END, NBS ENC	1197760	1197766
NOTES:			
1. CZ CHNLS SHOWN IN ALL POSITIONS AS REFERENCE ONLY			
2. IF BRACKETS FOR THAT BED LOCATION, WING BEDS ALWAYS REQUIRE BRACKETS			
3. Z BRACKET ASSEMBLY INCLUDES (2) BRACKETS WITH MOUNTING HARDWARE.			
REF DWG# 23D1228225			

Consists of channel with spacers installed on channel. The standard Roll Formed (RF) floor support is preassembled but not attached to the channel for shipping.

Note:

Maximum support crossmember center distance not to exceed 54" (1.37m). All hardware that has been loosened during installation must be retightened to 55 ft-lb (75 Nm) Failure to do so could cause structural failure.

Capacity:

1500 lb (680kg), typical per standard Roll Formed floor support.

RF Channel Spacer Z Bracket for Triple Wide:

Consists of 10 ga. Formed steel brackets and mounting hardware.

Mounting bolts secure bracket to web of side channel. Additional holes may need to be drilled.

17 RF Multi-Level Support

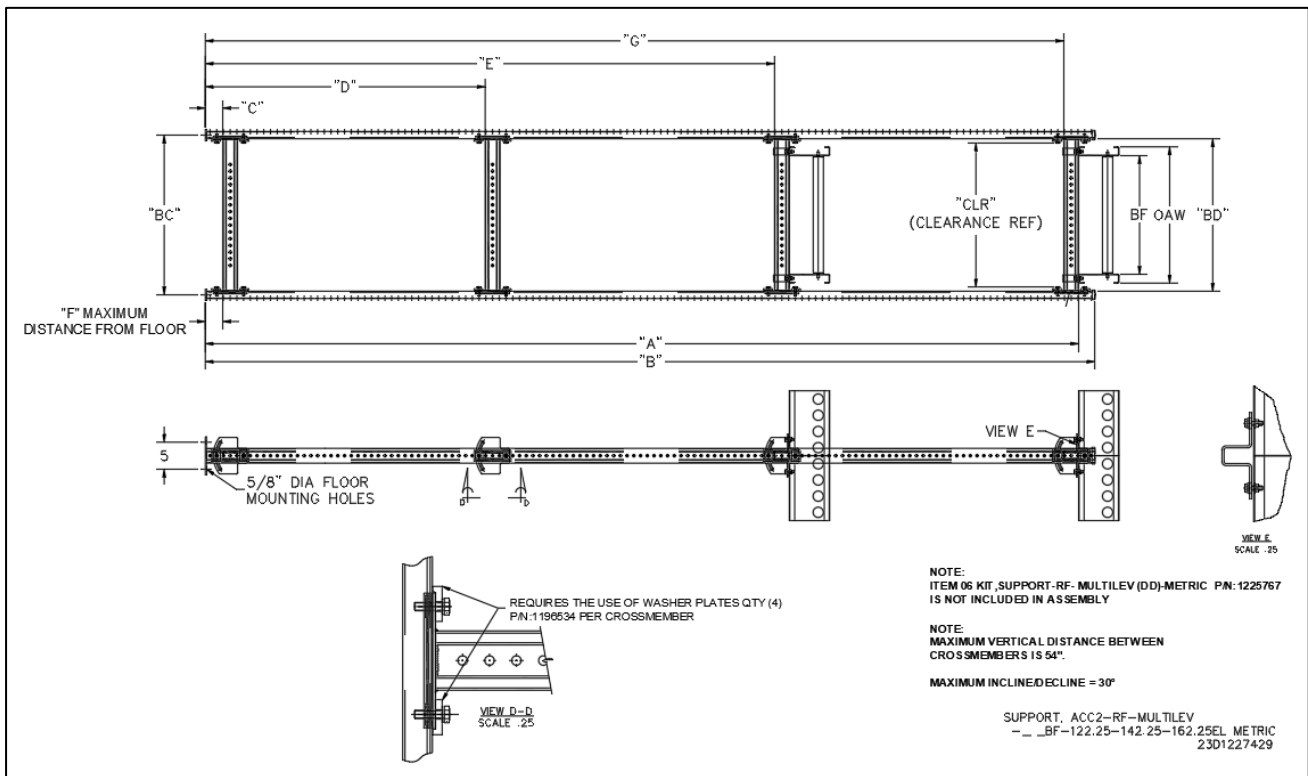

Standard Equipment

Consists of (2) leg weldments with footplate and crossmembers (quantity varies by elevation), (4) mounting straps, and mounting hardware. May also have cross braces (dependent on elevation).
C-channel spacers (if needed) sold separately.

Note:

Maximum support crossmember center distance not to exceed 54" (1.37m). All hardware that has been loosened during installation must be retightened to 55 ft-lb (75 Nm) Failure to do so could cause structural failure.

Clearance Between Uprights:

BF + 4-5/8" (11.7cm)

Conveyor Mounting:

Formed steel strap.

Two holes in mounting strap flange for bolting to bottom of bed channels or appropriate C-channel spacers (see C-channel spacer section for more details).

Capacity:

1,200 lb. (544kg) per level. Limited to two levels.

BF	"CLR"
	20 5/8 (523.875mm)
16	26 5/8 (676.275mm)
22	32 5/8 (828.675mm)
28	38 5/8 (981.075mm)
34	44 5/8 (1133.47mm)
40	50 5/8 (1285.87mm)
46	56 5/8 (1438.27mm)
52	
Ref DWG# 23D1227429	

Welded butt joints:

FORTNA with welded butt joints has been designed to be supported on 12' (366cm) centers maximum. Drive Beds must be supported at bed joints. For other support locations contact Applications Engineering for assistance.

Bolted butt joints:

FORTNA with bolted butt joints has been designed to be supported at every bed joint.

If unable to support at bed joints, order connection kits for bed joints or approved trussing (priced & available separately). Contact Applications Engineering for assistance.

Note:

Block or support bed while adjusting heights.

The total load on supports is to be FORTNA and system live load only. Added equipment weights to be considered by System Integrator and approved by FORTNA.

All floor supports are shipped assembled.

The capacities listed are based on both the weight of the conveyor and the product load. Weights that are not centered will reduce the capacities.

18 RF Multi-Level Heavy Duty Support

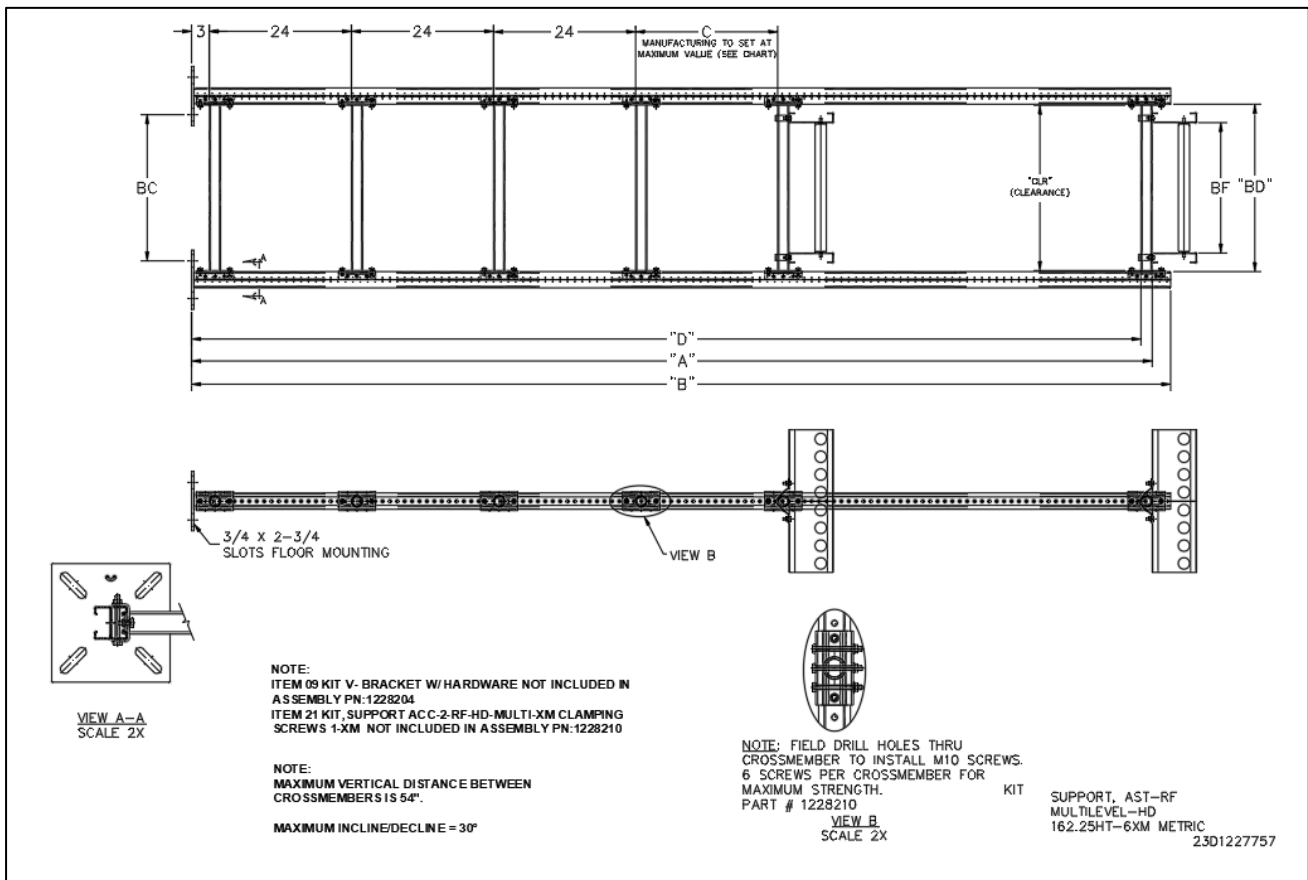

Standard Equipment

Consists of (2) leg weldments with footplate and crossmembers (quantity varies by elevation), (4) mounting straps, and mounting hardware. May also have cross braces (dependent on elevation).

C-channel spacers (if needed) sold separately.

Painted according to the job color specification.

Note:

Maximum support crossmember center distance not to exceed 54" (1.37m). All hardware that has been loosened during installation must be retightened to 55 ft-lb (75 Nm) Failure to do so could cause structural failure.

Clearance Between Uprights:

BF + 5-7/8" (14.9cm)

Conveyor Mounting:

Formed steel strap.

Two holes in mounting strap flange for bolting to bottom of bed channels or appropriate C-channel spacers (see C-channel spacer section for more details).

BF	"CLR"
16	21 7/8 (555.625mm)
22	27 7/8 (708.025mm)
28	33 7/8 (860.425)
34	39 7/8 (1012.825mm)
40	45 7/8 (1165.22mm)
46	51 7/8 (1317.63mm)
52	57 7/8 (1470.02mm)
Ref DWG# 23D1227757	

Static Capacity:

1,500 lb. (680kg) per level. Limited to two levels.

Dynamic Capacity:

To be determined by local Structural Engineer

Dynamic Load Testing

Note:

To be determined by local Structural Engineer

WARNING:

If RF Heavy Duty supports are used for “Seismic” conditions or ratings it shall be noted:

- Compliance assurance per all application codes and requirements is by others.
- FORTNA can provide drawings as needed to Systems Integrator for proper evaluation and approval by their Structural Engineer.

Crossmembers:

Bolted to leg uprights in lengths to match bed widths (fixed floor support width for each bed, width is not adjustable).

Note:

Maximum support crossmember center distance not to exceed 54” (1.3m).

Welded butt joints:

FORTNA with welded butt joints has been designed to be supported on 12’ (366cm) centers maximum. Drive Beds must be supported at bed joints. For other support locations contact Applications Engineering for assistance.

Bolted butt joints:

FORTNA with bolted butt joints has been designed to be supported at every bed joint.

If unable to support at bed joints, order connection kits for bed joints or approved trussing (priced & available separately). Contact Applications Engineering for assistance.

Note:

Block or support bed while adjusting heights.

Total load on supports is to be FORTNA and system live load only. Added equipment weights to be considered by System Integrator and approved by FORTNA.

The capacities listed are based on both the weight of the conveyor and the product load. Weights that are not centered will reduce the capacities.

Shipping:

All floor supports are shipped un-assembled in crates.

18.1 RF HD Multi Level Application for Maximum Strength

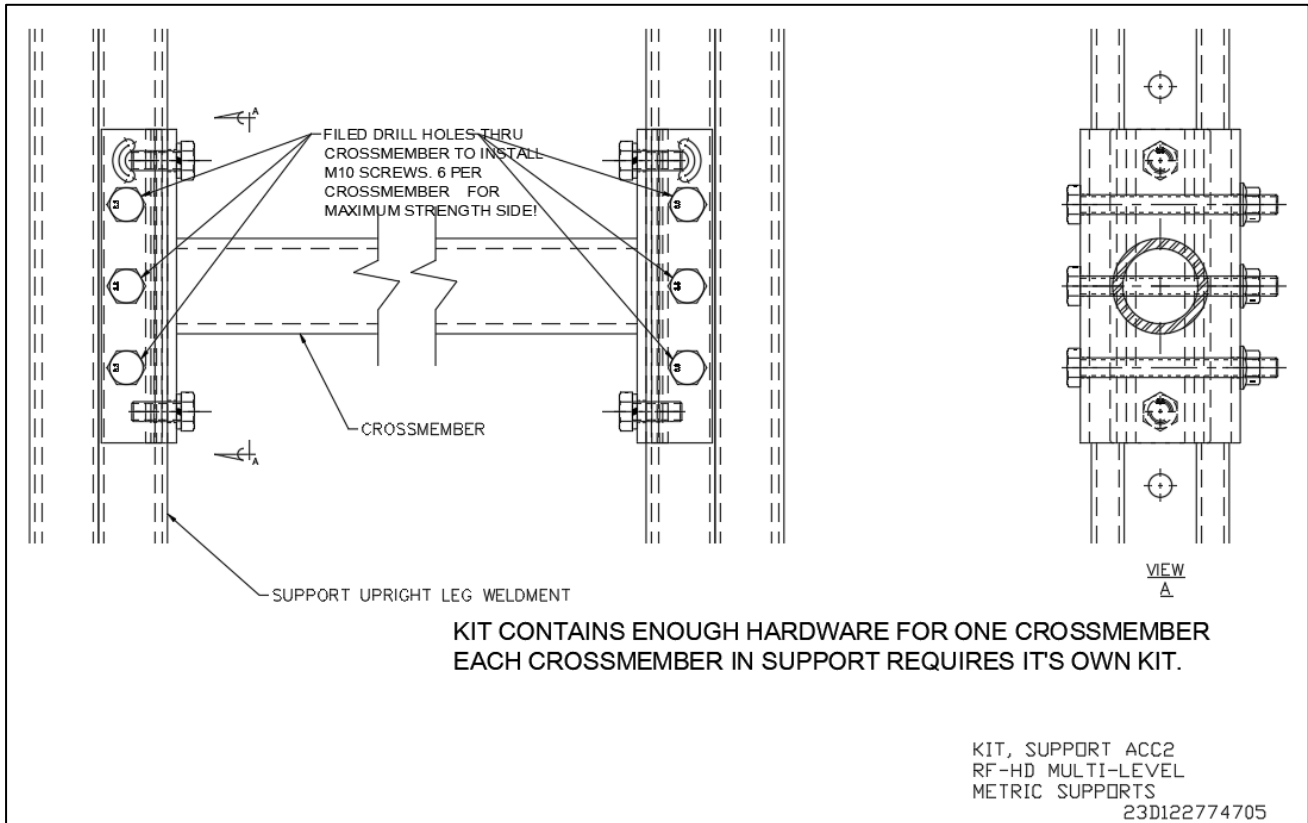

WARNING:

If RF Heavy Duty supports are used for “Seismic” conditions or ratings it shall be noted:

- Compliance assurance per all application codes and requirements is by others.
- FORTNA can provide drawings as needed to Systems Integrator for proper evaluation and approval by their Structural Engineer.

Note:

Maximum support crossmember center distance not to exceed 54” (1.37m). All hardware that has been loosened during installation must be retightened to 55 ft-lb (75 Nm) Failure to do so could cause structural failure.

19 C-Channel Spacers

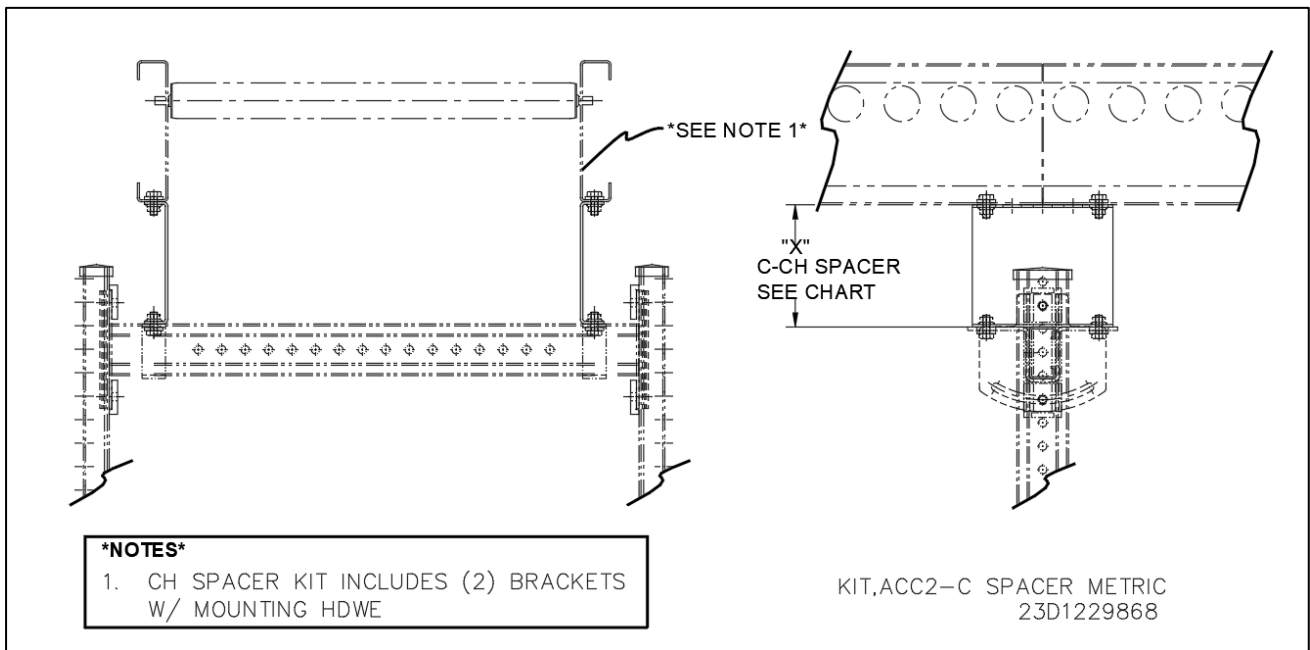

C-channel spacer options are used for different heights and kits.

C-channel spacers kits include (2) brackets with mounting hardware.

KIT, SPACER C-CH			
C-CH SPACER KIT	C-CH SPACER	FOR USE WITH CHANNEL TYPE	CH SPACER HEIGHT "X"
1229868	1197883	CZ, C6	1 1/2
	1197885	CZ LINE-SHAFT	3
1233231	1233459		3 1/2
	80700112	4.5"CH LINE-SHAFT	4 1/2
		9" CH LINE-SHAFT	N/A
	1197887	NBC END, NBS ENC	6 1/2
NOTE:			
1. CZ CHNLS SHOWN AS REFERENCE ONLY.			
2. CH SPACER KIT INCLUDES (2) BRACKETS W / MOUNTING HDWE.			
DWG#23D1229868			

20 Knee Braces

20.1 Standard Knee Braces

Stability along the conveyor length is achieved with knee braces. Braces resist stresses caused by direction of product flow, stops, and starts. Not every support requires bracing. Braces are used at the ends of straight runs and approximately every 30' in between.

STANDARD KNEE BRACES	
Part Number	Description
1225505	KIT, ACC-KNEE BRACE-KBB-W/BRKT-METRIC
1227668	KIT, ACC-KNEE BRACE-KBC-DBL W/BRKT-METRIC

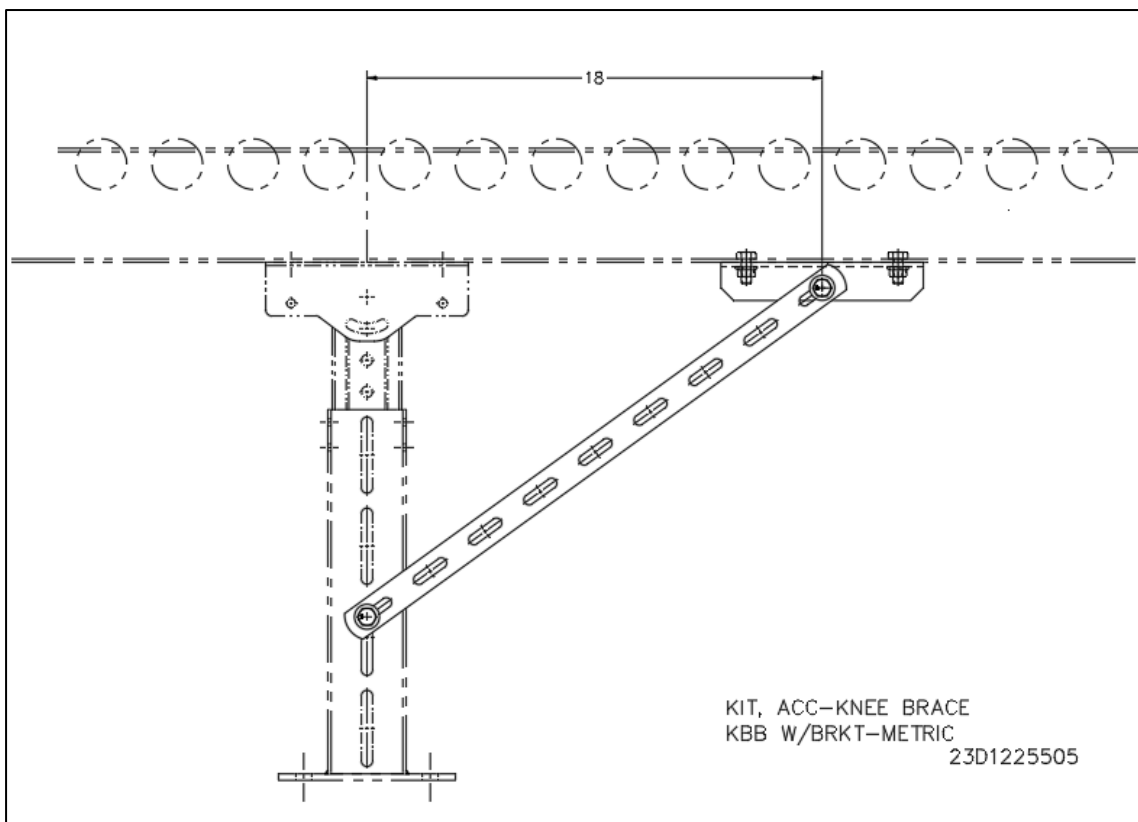

TYPE B (KBB): 1/4" (6mm) x 1-1/4" (32mm) x 24" (610mm) steel plate bolts to support upright and 7 ga. x 2-1/2" (64mm) x 8" (203mm) steel angle bracket bolted to bottom flange of bed, painted.

Knee Brace Kits Include: (2) Knee Braces each containing (1) Knee Brace Strip, and Hardware.

Optional use with supports 11.5"-50" (29.2-127 cm) elevation.

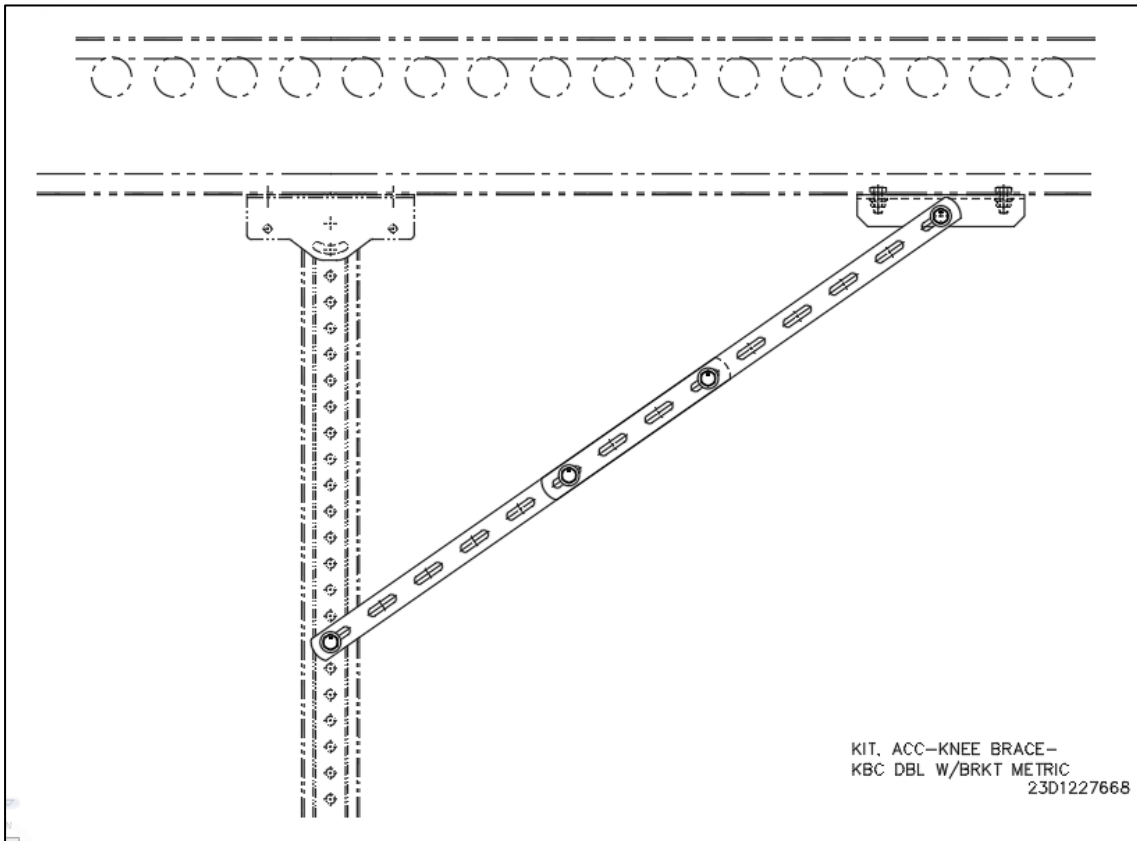

TYPE C (KBC): Same as Type “B” with two 24” (610mm) long steel plates.

Knee Brace Kits Include: (2) Knee Braces each containing (2) Knee Brace Strips, and Hardware.

Standard use with supports above 50” (127cm) elevation.

20.2 Multilevel Knee Braces

Multilevel knee braces require brackets for attaching knee braces to support uprights. These brackets are included in the Multilevel Knee Brace kits.

MULTILEVEL KNEE BRACES	
Part Number	Description
1225504	KIT, ACC2-RF-KNEE BRACE-ML-KBB-W/BRKT-METRIC
1227679	KIT, ACC2-RF-KNEE BRACE-ML-KBC-DBL W/BRKT-METRIC

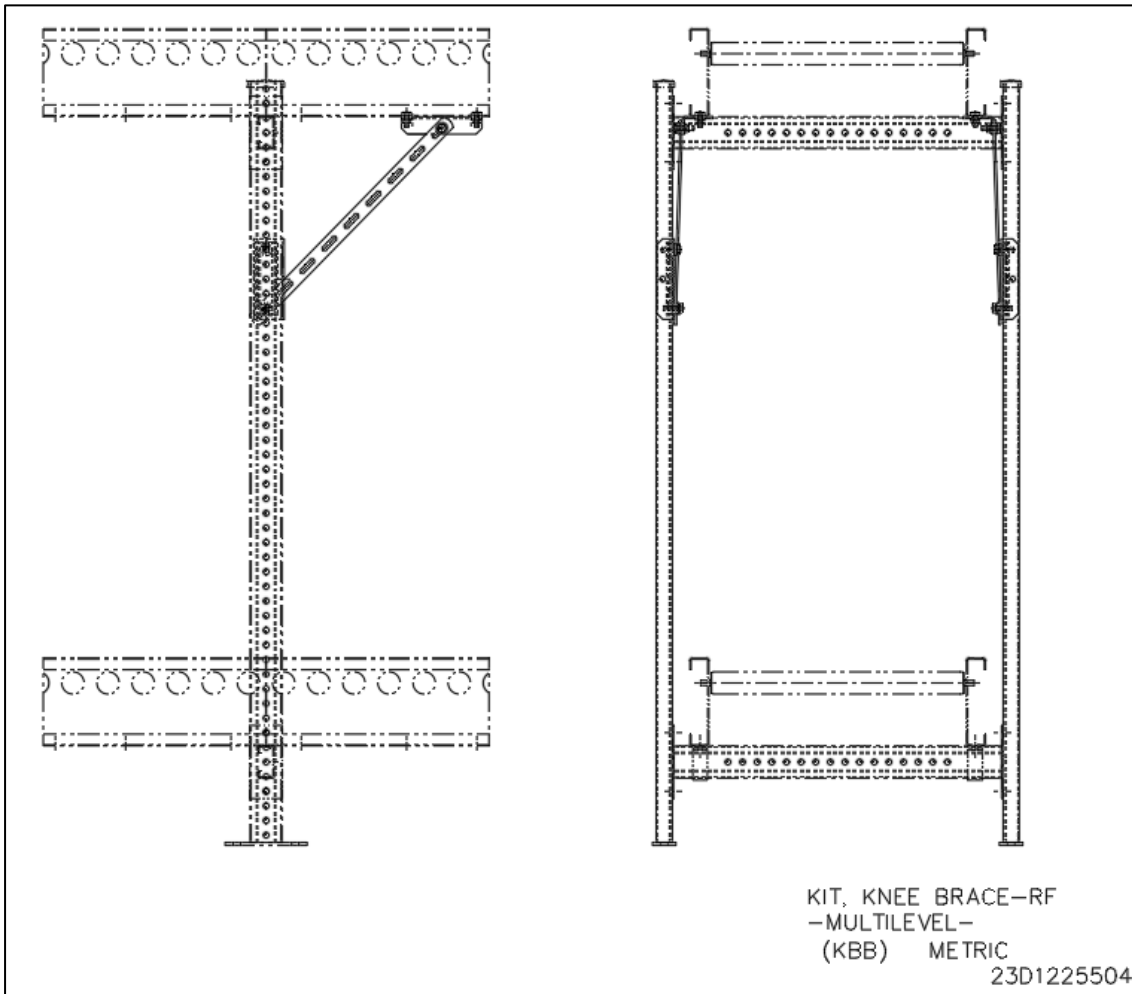

Type B (KBB): 1/4" (6mm) x 1-1/4" (32mm) x 24" (610mm) steel plate bolts to support upright and 7 ga. X 2-1/2" (64mm) x 8" (203mm) steel angle bracket bolted to bottom flange of bed, painted.

Knee Brace Kits Include: (2) Knee Brace Strips, (4) Angle Brackets, Knee Brace, (2) Nut Plates, and Hardware.

Optional use with supports up to 50" (127cm) elevation.

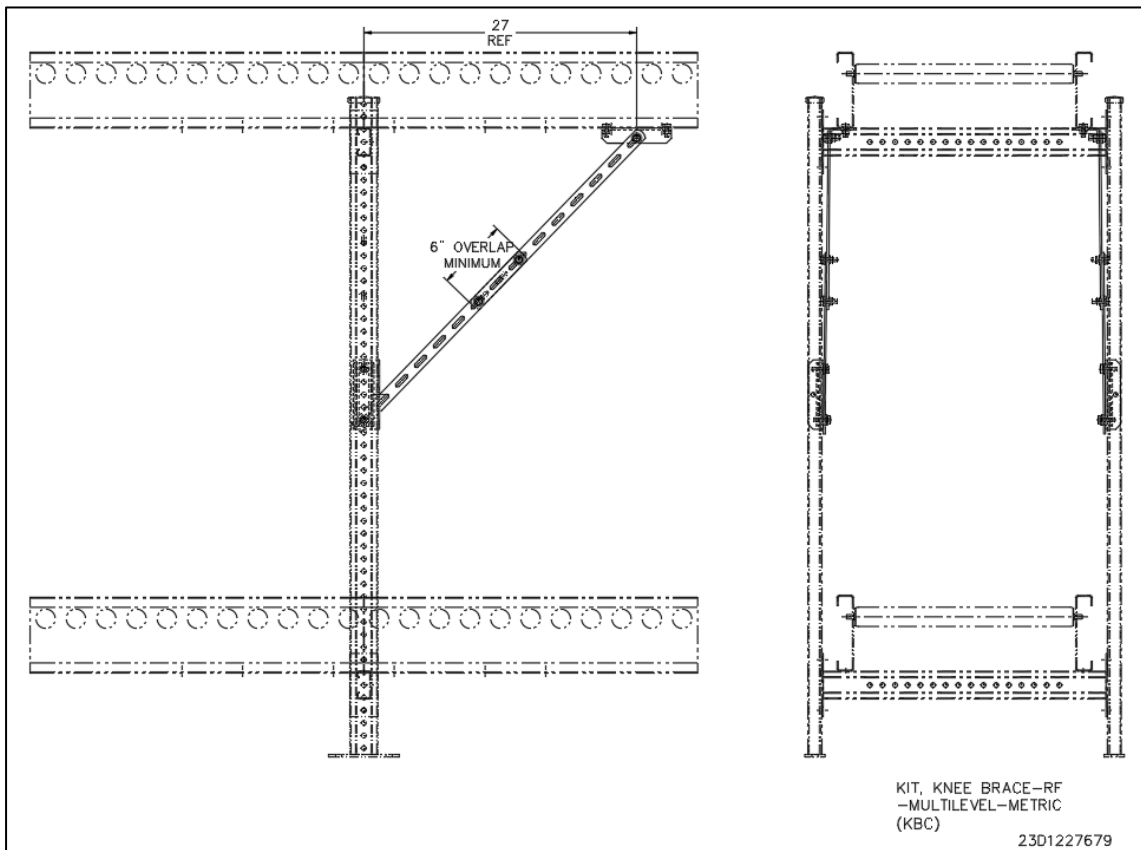

Type C (KBC): same as type “B” with two 24” (610mm) long steel plates.

Knee Brace Kits Include: (4) Knee Brace Strips, (4) Angle Brackets, Knee Brace, (2) Nut Plates and Hardware.

Standard use with supports above 50” (127cm) elevation.

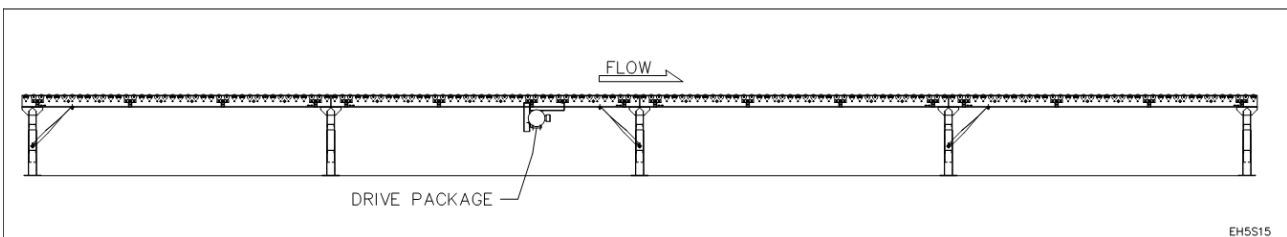

Mounted in tension on downstream side of support (except at drive) to resist imposed stresses caused by flow direction, starts, and stops. Recommended angle is 45°, bottom of bed to support upright.

21 Preventive Maintenance

General

Preventive maintenance will save expensive downtime, wasted energy costs, and increase the life of components. An accurate record keeping system will track component servicing history.

Periodic maintenance intervals may vary with load, speed, hours of operation, ambient temperature, humidity, etc. Intervals can be established by fairly frequent maintenance at first, and then lengthens the intervals as justified by observation of need based on history. The following schedule is based on 5 days per week, 8 hours per day operation under normal conditions.

Daily Inspection

DAILY INSPECTION CHECK	ACTION
Listen to everything for unusual noises or vibration.	Inspect and repair
Visually inspect to see that conveyor sections are clear and free of debris.	Clean conveyor free of debris
Check to see that all safety guards are in place.	Replace missing guards
Check for loose bolts or parts.	Tighten loose bolts and replace if missing

WARNING



Warning!

- Care should be taken when servicing any conveyor to prevent accidental injury.
- Check the loosened parts have been retightened and all guards reinstalled.

Indicates a medium level potentially hazardous situation that, if not avoided, could result in death or serious injury.

WARNING



Warning!

- After maintenance, **REPLACE** guards immediately.
- Keep **ALL** warning labels clean and clear of any obstructions.
- **Never** remove, deface, or paint over **WARNING** or **CAUTION** labels. Any damaged label will be replaced by FORTNA at no cost by contacting Lifetime Services.
- Ensure all re-located or new installed fasteners are set to proper torque settings per manufacture recommendations.

Indicates a medium level potentially hazardous situation that, if not avoided, could result in death or serious injury.

21.1 Inspection Sheet

SUPPORTS & CONNECTIONS PM INSPECTION				
Company Name:		Foreman or Maintenance Personnel #:		
Project #:		PM: Daily or Weekly Inspection		
City & State:		Date:		
CONVEYOR #				
#	DESCRIPTION	OK	CODE	COMMENTS
1	E-STOPS /PULL CORDS			
2	GUARDS, COVERS & NETTING			
3	ABNORMAL NOISE or VIBRATION			
4	LOOSE HARDWARE			
5	OTHER			
6				
7				
8				
9				
10				
COMMENTS:				
CODE REFERENCE NUMBER				
1 - LOOSE		10 - LOW OR EMPTY		
2 - BROKEN		11 - EXCESSIVE NOISE		
3 - MISSING		12 - REPLACE		
4 - WORN		13 - LEAKING		
5 - DIRTY and/or DRY		14 - RUNNING HOT		
6 - EXCESSIVE TENSION		15 - INCORRECT		
7 - BENT and/or DENTED		16 - SLIPPAGE		
8 - WRONG SIZE		17 - VIBRATION		
9- OUT OF ALIGNMENT		18 - OTHER EXPLAIN:		

22 Decommissioning and Disposal

Caution!

Decommissioning and dismantling must be entrusted to personnel specialized in such activities.

Only those in charge of the dismantling and final waste disposal phase can perform the following activities:

- Mechanical and electric disconnection of parts according to disassembly instructions and design diagrams.
- Transporting parts from the position of use to the waste disposal facility for separation of parts.

Caution!

The partly completed machine does not contain components or hazardous substances which require special removal procedures.

22.1 Decommissioning

If the partly completed machine is not to be used for a long time, it must be set safely and stored in a closed, dry, and clean environment to preserve all the parts that compose it as best as possible.

Proceed as follows to decommission the partly completed machine:

Step 1.

1. Turn off and lock/out the main power supply panel.
2. Turn off and lock/out the power supply to the partly completed machine power box.
3. Disconnect the electrical connection such as the driver cards, air lines, or power harness connections from the partly completed machine and the adjacent partly completed machine.
4. Clean all the components of the partly completed machine (refer to the “Maintenance” chapter).
5. Secure the partly completed machine before you unanchored it.
6. Move partly completed machine to designated storage location

22.2 Disposal

When you wish to dispose of the partly completed machine, secure it.

To dispose of the partly completed machine, proceed as described below:

Step 2.

1. Turn off and lock/out the main power supply panel.
2. Disconnect the power supply to the partly completed machine.
3. Disconnect the electrical connection such as the driver cards, air lines, or power harness connections from the partly completed machine and the adjacent partly completed machine.
4. Clean all the components of the partly completed machine (refer to the “Maintenance” chapter).
5. Secure the partly completed machine before you unanchored it.
6. Prepare a spacious working area, free from obstacles, to safely dismantle the partly completed machine.

7. Remove all the cables and electrical components, adopting the safety measures required for such interventions.
8. Disassemble all the components, separating the resulting material into groups, for differentiated disposal.

Caution!

The partly completed machine does not contain components or hazardous substances which require special removal procedures.

Caution!

Always comply with the laws in force in the country of installation/incorporation regarding partly completed machine disposal.



FORTNA

231.798.4547

Email : usinfo@fortna-conveyor.com

Web Site : fortna-conveyor.com



Manufacturing Location

FORTNA Inc.

131 Griffin Way

Mt. Washington, KY 40047

Corporate Office

FORTNA Inc.

1349 W Peachtree St. NW

Suite 1300

Atlanta, GA 30309

FORTNA.com

As standards, specifications, and design change from time to time, please ask for confirmation of the information given in this publication.

©2026 FORTNA Inc. All rights reserved
